

ACE-SXE

Advanced Stand-Alone Step Motor Controller With USB 2.0/RS-485 communication



COPYRIGHT © 2008 ARCUS,
ALL RIGHTS RESERVED

First edition, January 2008

ARCUS TECHNOLOGY copyrights this document. You may not reproduce or translate into any language in any form and means any part of this publication without the written permission from ARCUS.

ARCUS makes no representations or warranties regarding the content of this document. We reserve the right to revise this document any time without notice and obligation.

Revision History:

- 1.10 – 1st Release
- 1.17 – 2nd Release
- 1.18 – 3rd Release

Firmware Compatibility:

†V234BL

†If your module's firmware version number is less than the listed value, contact Arcus for the appropriate documentation. Arcus reserves the right to change the firmware without notice.

Table of Contents

1. Introduction.....	7
Features	7
2. Electrical and Thermal Specifications	9
Power Requirement.....	9
Temperature Ratings †	9
Digital Inputs †	9
Digital Outputs.....	9
Enable Output	9
Analog Inputs.....	9
3. Dimensions	10
4. Connections.....	11
2-Pin Connector (5.08mm)	11
14-Pin Connector (2mm)	11
18-Pin Connector (2mm)	12
ACE-SXE Interface Circuit	14
Digital Outputs.....	15
Enable Output	15
Digital Inputs	15
Pulse and Direction Outputs	16
Encoder Input Connection	17
5. Getting Started	18
Typical Setup	18
Windows GUI.....	19
Main Control Screen.....	20
A. Status.....	21
B. Control	22
C. Digital Input / Output.....	23
D. Analog Inputs.....	24
E. Product Information	24
F. Terminal.....	24
G. Setup	25
H. Standalone Program File Management.....	27
I. Standalone Program Editor	28
J. Standalone Processing	28
K. Variable Status	29
M. On-the-fly Speed Change.....	30
N. About.....	30
6. Motion Control Overview.....	31
Motion Profile.....	31
On-the-fly Speed Change.....	32
Analog Inputs.....	32
Joystick Control	32
Digital Inputs / Outputs.....	33
Motor Power	34

Polarity	34
Positional Moves.....	35
On-The-Fly Target Position Change.....	35
Jogging.....	35
Stopping Motor	35
Homing	36
Home Input Only (High speed only)	36
Home Input Only (High speed and low speed).....	36
Limit Only.....	37
Motor Position	38
Motor Status.....	39
Limit Inputs.....	39
Latch Input	39
StepNLoop Closed Loop Control	40
Device Number	42
Baud Rate Setting	42
Sync Output	43
Broadcasting over RS-485	44
Response type selection	44
Standalone Programming.....	45
Communication Time-out Feature (Watchdog).....	46
Storing to Flash.....	46
7. Communication – USB	48
USB Communication API Functions.....	48
USB Communication Issues	49
8. Communication – RS-485 (ASCII)	50
Communication Port Settings	50
ASCII Protocol.....	50
9. Communication - DIO	51
DIO Latency.....	51
Setting Up DIO Parameters	51
Examples.....	52
Using DIO.....	53
10. ASCII Language Specification	55
Error Codes	59
11. Standalone Language Specification	60
;	60
ABORTX	60
ABS.....	60
ACC	61
AI[1-2]	61
DELAY	62
DI	62
DI[1-6]	62
DO.....	63
DO[1-2].....	63

ECLEARX	64
ECLEARSX	64
ELSE	64
ELSEIF	64
END	65
ENDIF	65
ENDSUB	66
ENDWHILE	66
EO	66
EX	67
GOSUB	67
HLHOMEX[+ or -]	67
HOMEX[+ or -]	68
HSPD	68
IF	68
INC	69
JOGX[+ or -]	69
JOYENA	69
JOYHSX	69
JOYDELX	70
JOYNOX	70
JOYNIX	70
JOYPIX	70
JOYPOX	71
JOYTOLX	71
LHOMEX[+ or -]	71
LSPD	71
LTX	72
LTEX	72
LTPX	72
LTSX	72
MSTX	73
PX	73
PS	73
SCVX	74
SLX	74
SLSX	74
SSPDX	75
SSPDMX	75
STOPX	75
STORE	76
SYNCFGX	76
SYNOFFX	76
SYNONX	76
SYNPOSX	77
SYNSTATX	77

SYNTIMEX	77
SUB	77
V[1-100].....	78
WAITX	78
WHILE.....	79
X.....	79
ZHOMEX[+ or -].....	80
ZOMEX[+ or -].....	80
12. Example Standalone Programs	81
Standalone Example Program 1 – Single Thread	81
Standalone Example Program 2 – Single Thread	81
Standalone Example Program 3 – Single Thread	81
Standalone Example Program 4 – Single Thread	82
Standalone Example Program 5 – Single Thread	82
Standalone Example Program 6 – Single Thread	83
Standalone Example Program 7 – Multi Thread.....	84
Standalone Example Program 8 – Multi Thread.....	85
Appendix A: Speed Settings	86
Acceleration/Deceleration Range	86
Acceleration/Deceleration Range – Positional Move	87

1. Introduction

ACE-SXE is an advanced stepper controller motion product. Feature highlights include encoder support (closed-loop position verification) and analog inputs (joystick control).

Communication to the ACE-SXE can be established over USB or RS-485. It is also possible to download a stand-alone program to the device and have it run independent of a host.

Windows and Linux drivers as well as sample source code are available to aid you in your software development.

Features

ACE-SXE

- USB 2.0 communication
- 6MHz max pulse support
- RS-485 ASCII communication
 - 9600, 19200, 38400, 57600, 115200 bps
- Digital IO communication
 - 4 bit motion profile select inputs (DI3-DI6)
 - One start motion input (DI1)
 - One abort/clear motion input (DI2)
 - One in position output (DO1)
 - One error output (DO2)
- A/B/Z differential encoder inputs
 - StepNLoop closed loop control (position verification)
- 2 x 10-bit analog inputs
 - Joystick control
- Opto-isolated I/O
 - 6 x inputs
 - 2 x outputs
 - 1 x High speed position capture latch input
 - +Limit/-Limit/Home inputs
- Homing routines:
 - Home input only (high speed)
 - Home input only (high speed + low speed)
 - Limit only
 - Z-index encoder channel only
 - Home input + Z index encoder channel
- S-curve or trapezoidal acceleration profile control
- On-the-fly speed change

Contacting Support

For technical support contact: support@arcus-technology.com.

Or, contact your local distributor for technical support.

2. Electrical and Thermal Specifications

Power Requirement

Regulated Voltage: **+12 to +48 VDC**
 Current (Max): **500 mA**

Temperature Ratings †

Operating Temperature: **-20°C to +80°C**
 Storage Temperature: **-55°C to +150°C**
 † Based on component ratings

Digital Inputs †

Type: **Opto-isolated NPN inputs**
 Opto-isolator supply: **+12 to +24 VDC**
 Maximum forward diode current: **45 mA**
 † Includes limit, home and latch

Digital Outputs

Type: **Opto-isolated open-collector NPN outputs**
 Max voltage at collector: **+24 VDC**
 Max sink current at 24VDC: **†90 mA**
 † A current limiting resistor is required

Enable Output

Type: **Open-collector NPN output (2N5088BU)**
 Max voltage at collector: **+24 VDC**
 Max sink current at 24VDC: **†90 mA**
 † A current limiting resistor is required

Analog Inputs

Type: **Voltage**
 Voltage input: **+0 to +5VDC**
 Max current: **22 mA**

3. Dimensions

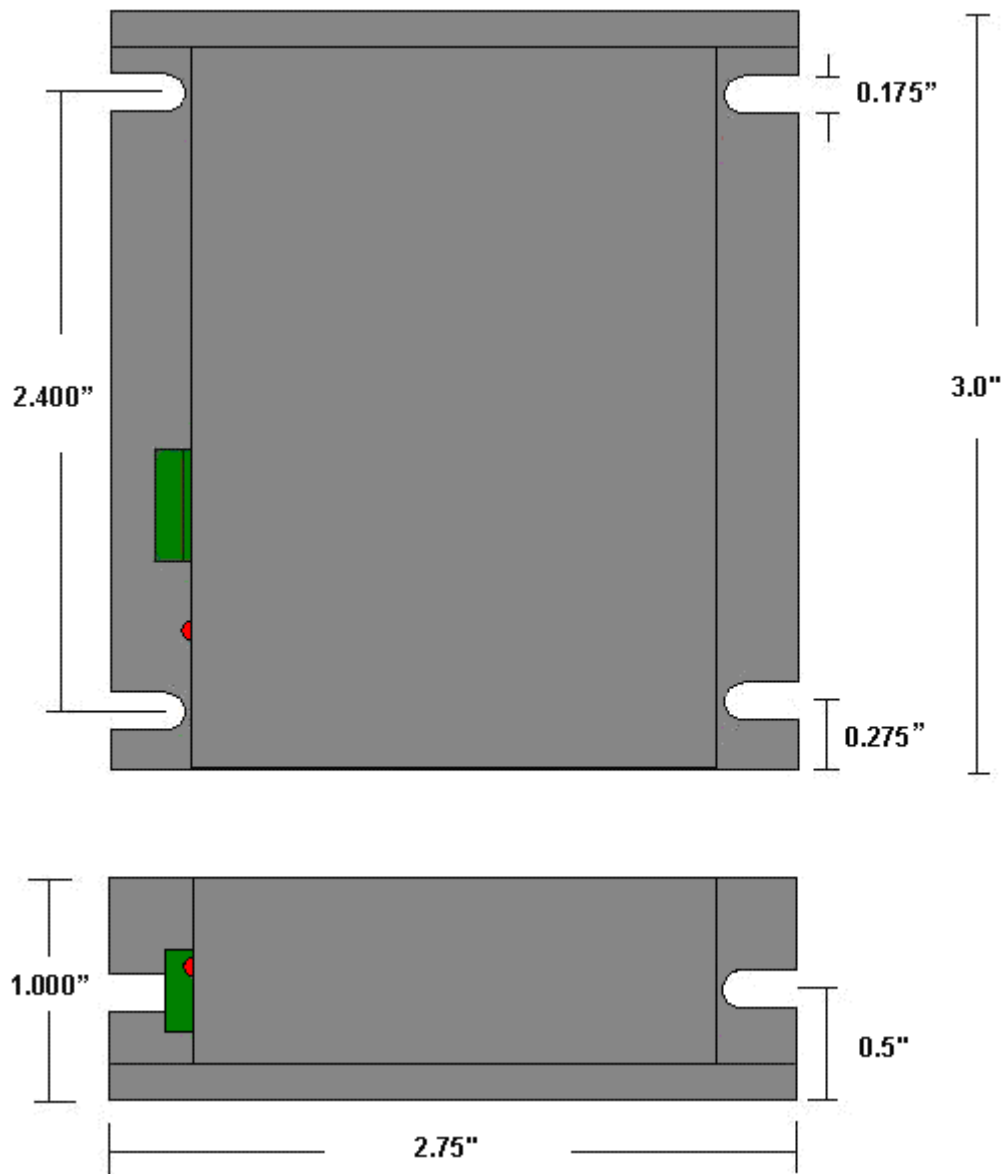

Figure 3.0

†All dimensions in inches

4. Connections



Figure 4.0

2-Pin Connector (5.08mm)

Pin #	In/Out	Name	Description
1	I	G	Ground
2	I	V+	Power Input +12 to +48 VDC

Table 4.0

Mating Connector Description: 2 pin 0.2" (5.08mm) connector
 Mating Connector Manufacturer: On-Shore
 Mating Connector Manufacturer Part: †EDZ950/2

† Other 5.08mm compatible connectors can be used.

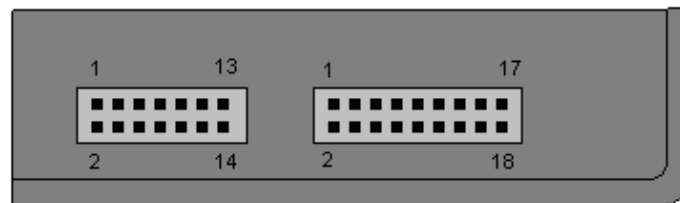

Figure 4.1

14-Pin Connector (2mm)

Pin #	In/Out	Name	Description
1	O	V+ OUT	Shorted to pin 2 (V+) of the 2-pin 5.08mm connector
2	I	OPTO	+12 to +24VDC opto-supply input – used for limit, home and digital inputs
3	I	-LIM	Minus limit input
4	I	+LIM	Plus limit input
5	I	LATCH	Latch input
6	I	HOME	Home input
7	I	DI2	Digital Input 2. When DIO control mode is enabled, DI2 is designated as the (Abort/Clear) signal.

8	I	DI1	Digital Input 1. When DIO control mode is enabled, DI1 is designated as the (Start) signal.
9	I	DI4	Digital Input 4. When DIO control mode is enabled, DI4 is designated as the 2 nd bit for motion profile selection (Select 2).
10	I	DI3	Digital Input 3. When DIO control mode is enabled, DI3 is designated as the LSB bit for motion profile selection (Select 1).
11	I	DI6	Digital Input 6. When DIO control mode is enabled, DI6 is designated as the 4 th bit for motion profile selection (Select 4).
12	I	DI5	Digital Input 5. When DIO control mode is enabled, DI5 is designated as the 3 rd bit for motion profile selection (Select 3).
13	O	DO2	Digital Output 2. When DIO control mode is enabled, DO2 is designated as the (Error) signal.
14	O	DO1	Digital Output 1. When DIO control mode is enabled, DO1 is designated as the (In Pos) signal.

Table 4.1

Mating Connector Description: 14 pin 2mm dual row connector
Mating Connector Manufacturer: HIROSE
Mating Connector Housing Part Number: DF11-14DS-2C
Mating Connector Pin Part Number: DF11-2428SC

18-Pin Connector (2mm)

Pin #	In/Out	Name	Description
1	O	GND	Shorted to pin 1 (GND) of the 2-pin 5.08mm connector
2	O	5V	5V output from controller – from on-board regulator
3	I	/Ae	Differential encoder /A channel
4	I	Ae	Differential encoder A channel
5	I	/Be	Differential encoder /B channel
6	I	Be	Differential encoder B channel
7	I	/Ze	Differential encoder /Z channel
8	I	Ze	Differential encoder Z channel
9	O	PUL-	Differential negative pulse output
10	O	PUL+	Differential positive pulse output
11	O	DIR-	Differential negative direction output
12	O	DIR+	Differential positive direction output
13	O	5V	5V output from controller – from on-board regulator
14	O	ENA	Enable output

15	I	AI2	Analog Input 2
16	I	AI1	Analog Input 1
17	I	485-	RS-485 minus signal
18	I	485+	RS-485 plus signal

Table 4.2

Mating Connector Description: 18 pin 2mm dual row connector
 Mating Connector Manufacturer: HIROSE
 Mating Connector Housing Part Number: DF11-18DS-2C
 Mating Connector Pin Part Number: DF11-2428S

ACE-SXE Interface Circuit

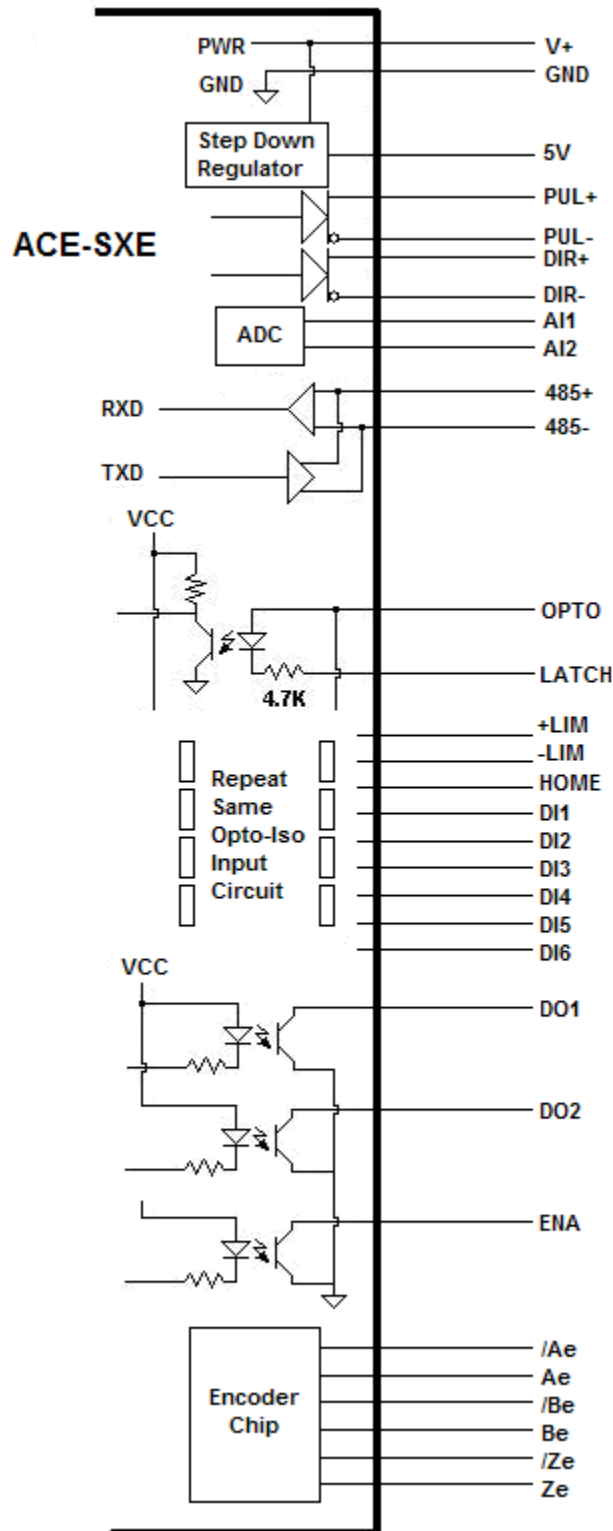

Figure 4.2

Digital Outputs

Figure 4.3 shows an example wiring to the digital output.

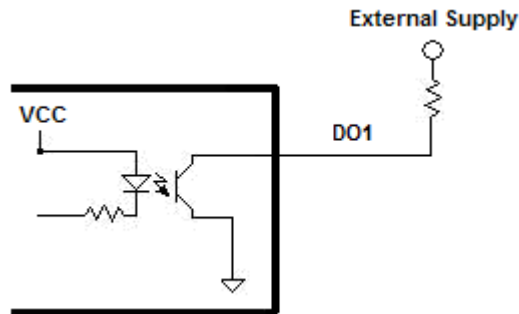

Figure 4.3

WARNING: The maximum sink current for digital outputs is 90 mA. Take caution to select the appropriate external supply and pull-up resistance to limit the sink current below this level.

Enable Output

Figure 4.4 shows the detailed schematic of the enable output.

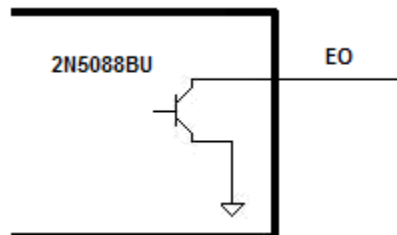

Figure 4.4

WARNING: The maximum sink current for the enable outputs is 90 mA. Take caution to select the appropriate external supply and pull-up resistance to limit the sink current below this level.

Digital Inputs

Figure 4.5 shows the detailed schematic of the opto-isolated inputs.

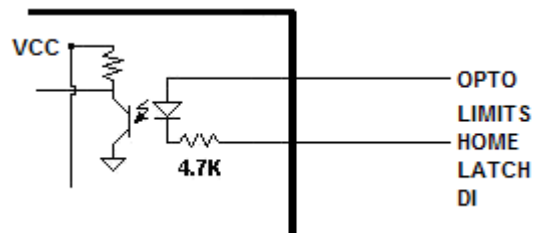

Figure 4.5

Pulse and Direction Outputs

Pulse and Direction Outputs are differential outputs using 75LS191. Figure 4.6 shows an example of a differential ended connection. Figure 4.7 shows an example of a single-ended connection.

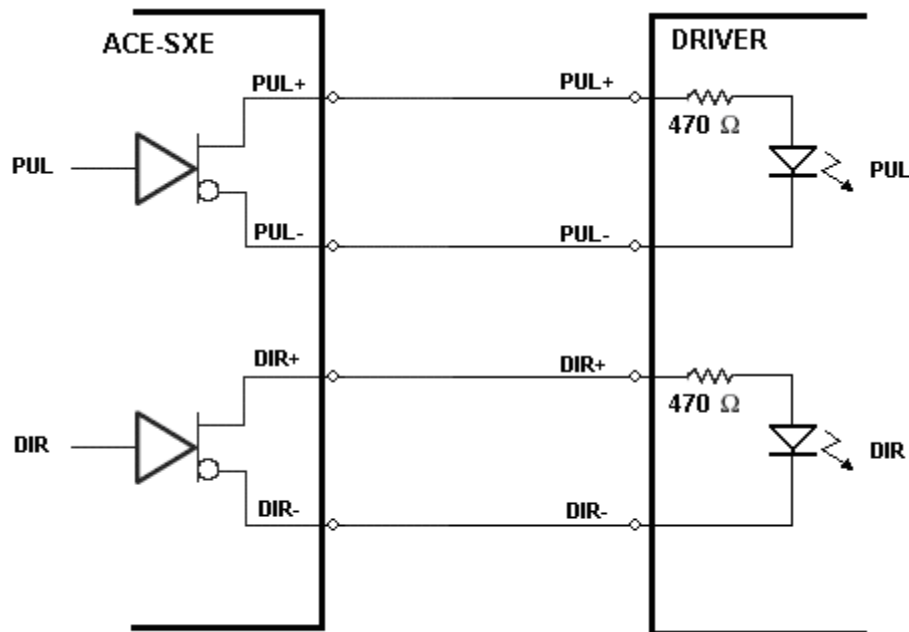

Figure 4.6

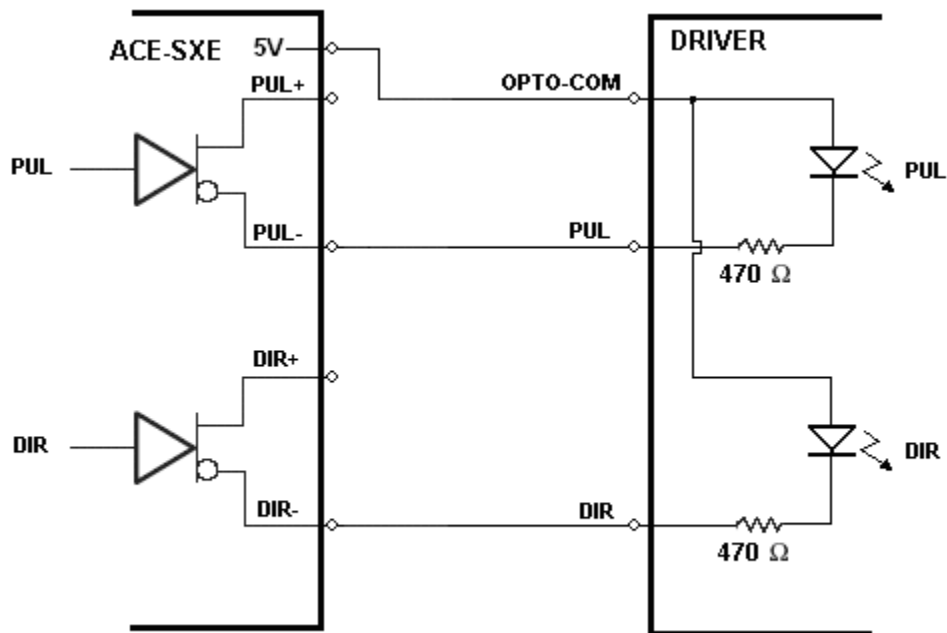

Figure 4.7

Encoder Input Connection

Both single-ended and differential quadrature encoder inputs are accepted.

When using single-ended encoders, use the /A, /B, and /Z inputs.

+5V supply and Ground signals are available to power the encoder. Make sure that the total current usage is less than 200mA for the +5V.

The maximum encoder frequency is 3MHz.

5. Getting Started

Typical Setup

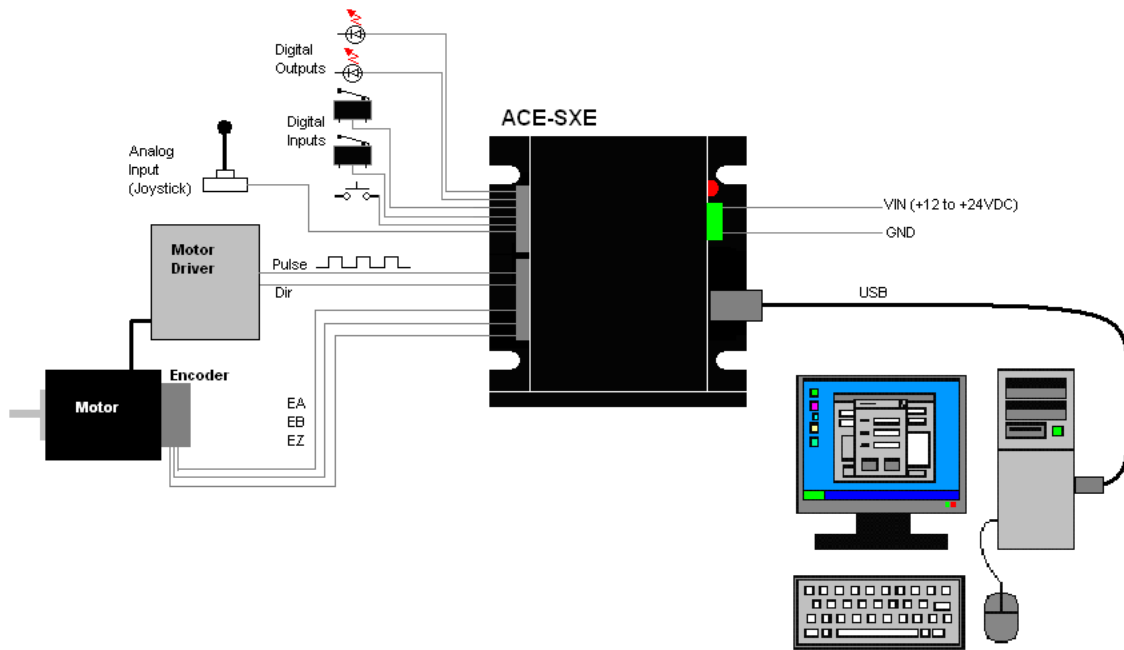

Figure 5.0

Important Note: In order to communicate with ACE-SXE via USB, the proper driver must be first installed. Before connecting the ACE-SXE device or running any program, please go to the Arcus web site, download the USB driver installation instructions and run the USB Driver Installation Program.

Windows GUI

ACE-SXE comes with a Windows GUI program to test, program, compile, download, and debug the controller.

Make sure that the USB driver is installed properly before running the controller.

Startup the ACE-SXE GUI program and you will see following screen.

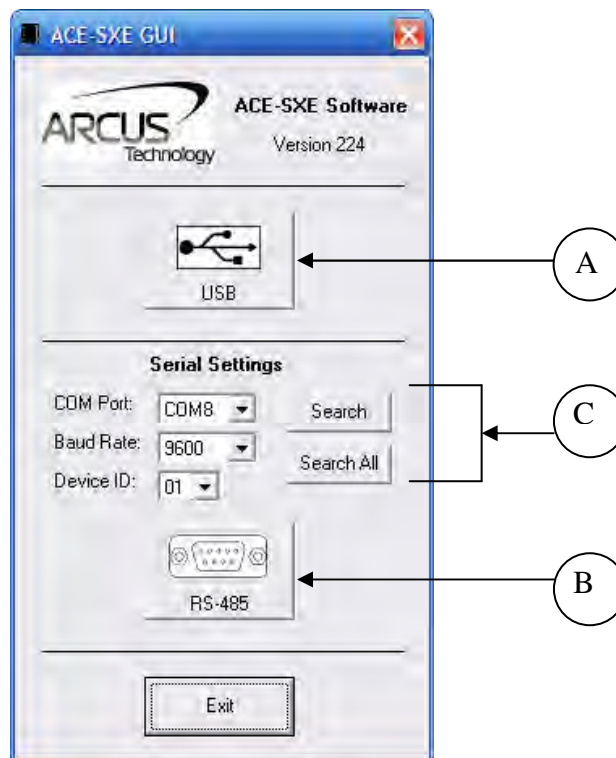

Figure 5.1

- A. Open USB Communication.
- B. Open RS-485 communication.
- C. If communication port or the baud rate is not known for RS-485, use these buttons to search for the device.

Main Control Screen

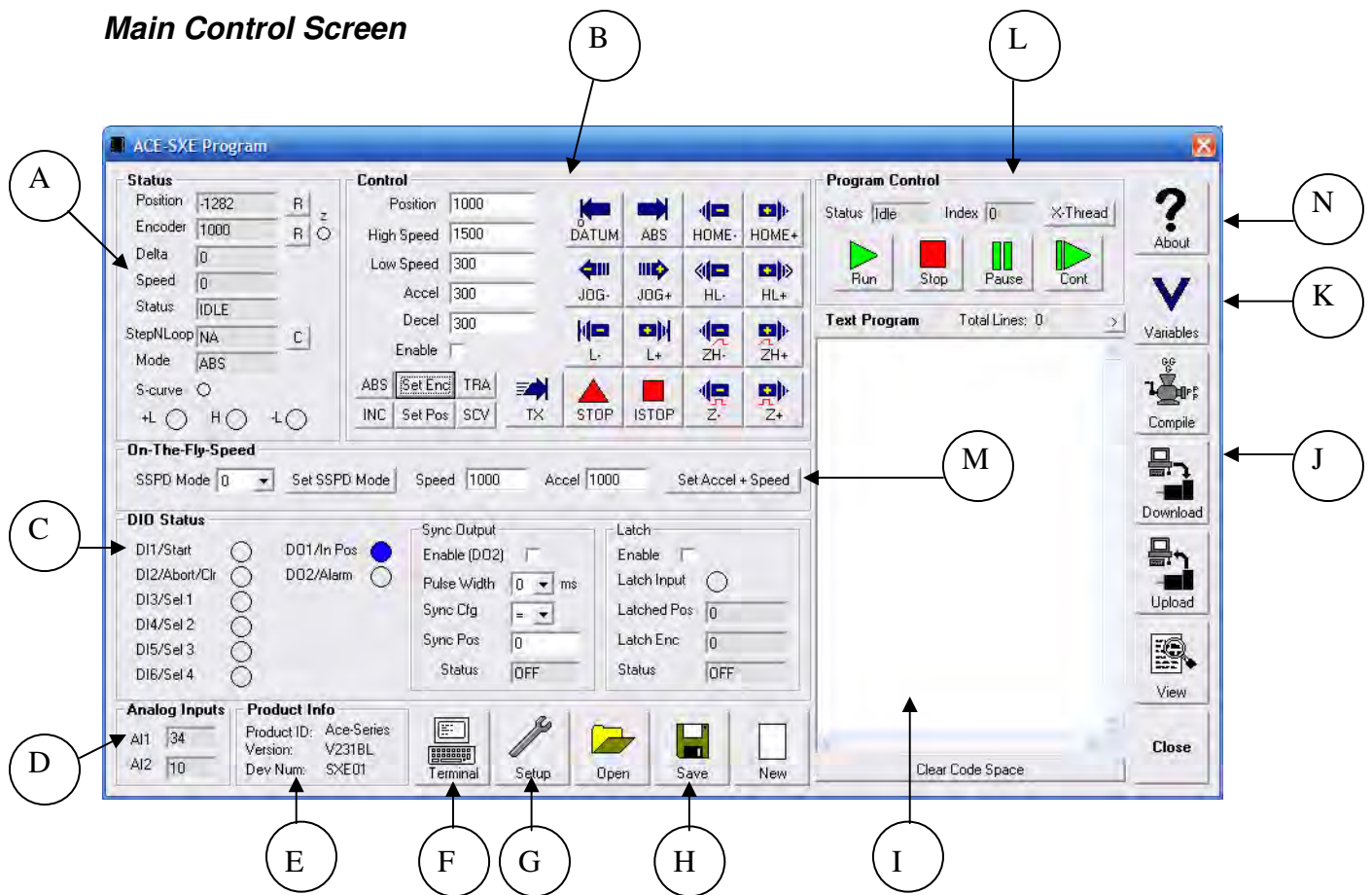

Figure 5.2

A. Status

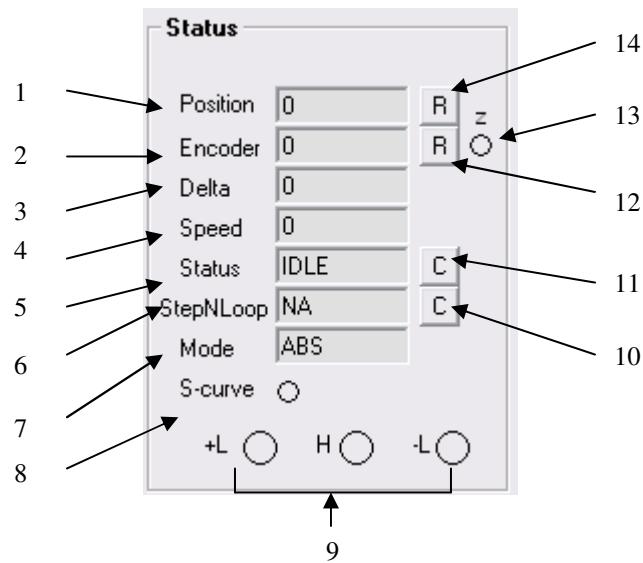

Figure 5.3

1. **Pulse Counter** – displays the current pulse position counter. When StepNLoop is enabled, this displays the Target position.
2. **Encoder Counter** – displays the current encoder position counter.
3. **Delta Counter** – valid only for StepNLoop. Displays the difference between the target position and the actual position.
4. **Speed** – displays the current pulse speed output rate. Value is in pulses/second. While the controller is in StepNLoop mode, this value shows encoder counts/second.
5. **Motion Status** – displays current motion status by displaying one of the following status:
 - IDLE: motor is not moving
 - ACCEL: motion is in acceleration
 - DECEL: motion is in deceleration
 - CONST: motion is in constant speed
 - -LIM ERR: minus limit error
 - +LIM ERR: plus limit error
6. **StepNLoop Status** – valid only when StepNLoop is enabled and displays current StepNLoop status by displaying one of the following:
 - NA: StepNLoop is disabled
 - IDLE: motor is not moving
 - MOVING: target move is in progress
 - JOGGING: jog move is in progress
 - HOMING: homing is in progress
 - LHOMING: limit homing in progress
 - Z-HOMING: homing using Z-index channel in progress
 - ERR-STALL: StepNLoop has stalled.
 - ERR-LIM: plus/minus limit error
7. **Move Mode** – displays current move mode

- ABS: all the move commands by X[pos] command will be absolute moves
 - INC: all the move commands by X[pos] command will be increment moves.
8. **S-curve Status** – Displays whether the moves are in trapezoidal or S-curve acceleration.
 9. **Limit/Home Input Status** – Limit and Home input status.
 10. **Reset StepNLoop Error** – When the StepNLoop status is in error, use this button to clear the StepNLoop error. StepNLoop status will return to IDLE after error is cleared.
 11. **Reset Status Error** – When motion status is in error, use this button to clear the error.
 12. **Reset Encoder Counter** – Encoder counter can be reset to zero using this button.
 13. **Encoder Z Index Channel Status** – Encoder Z index channel status is displayed.
 14. **Reset Pulse Counter** – Pulse counter can be reset to zero using this button.

B. Control

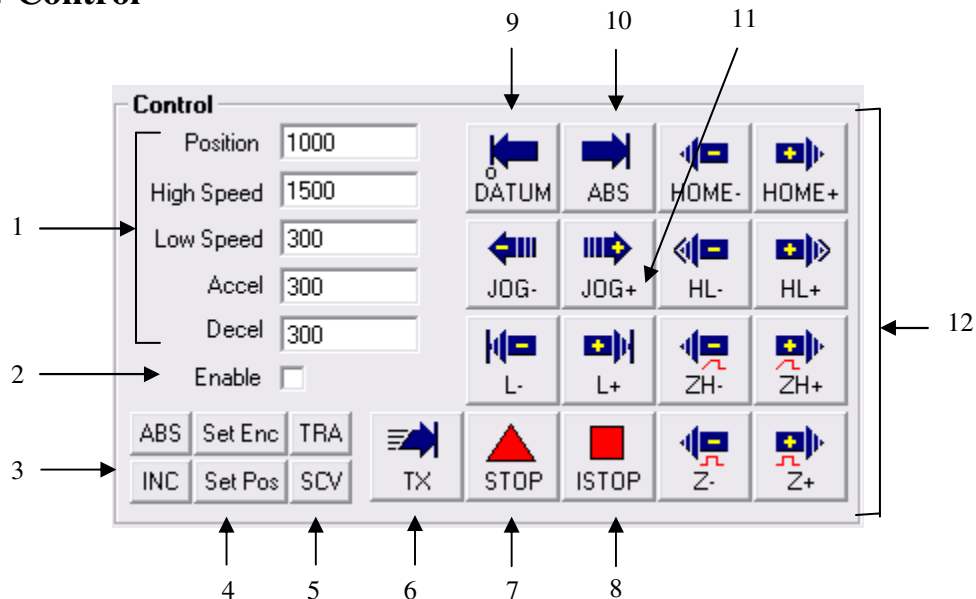

Figure 5.4

1. Target Position/Speed/Accel

- Target Position: use this to set the target position. For normal open loop mode, this position is the pulse counts and when StepNLoop is enabled this target position is in encoder counts.
- High/Low Speed: use this to set the speed of the move. For normal open loop mode, this value is in pulses/second and when StepNLoop is enabled this value is in encoder counts/second
- Accel: acceleration value in milliseconds

- Decel: deceleration value in milliseconds
2. **Enable Driver Power** – use this button to enable and disable the power to the micro-step driver.
 3. **Select Move Mode** – use these buttons to select absolute or incremental move mode.
 4. **Set Position** – use these buttons to set the encoder or pulse position to “Position” value
 5. **Select Acceleration Mode** – use these buttons to select trapezoidal or S-curve acceleration mode.
 6. **On-the-fly target change** – Change the target position on-the-fly
 7. **Ramp Stop** – use this button to stop the motion with deceleration.
 8. **Immediate Stop** – use this button to stop the motion immediately. *We recommend that ramp stop be used whenever possible to reduce the impact to the motor and the system.*
 9. **Move back to zero** – use this to move the motor to the zero target position. When in absolute mode, the axis will move to zero position (zero encoder position when in StepNLoop and zero pulse position when in open loop).
 10. **Perform Absolute Move** – use this to move the motor to the target position. When in absolute mode, the axis will move to the absolute target position. When in incremental mode, the axis will move incrementally.
 11. **Jogging** – jog motor in either positive or negative direction
 12. **Perform Homing** – Three different homing routines are available
 - HOME: homing is done using only the home switch at high speed.
 - HL: homing is done using the home switch at high speed and low speed
 - L: homing is done using the limit switch
 - ZH: homing is done using the home switch first and then the Z index channel of the encoder.
 - Z: homing is done only using the Z index channel of the encoder.

C. Digital Input / Output

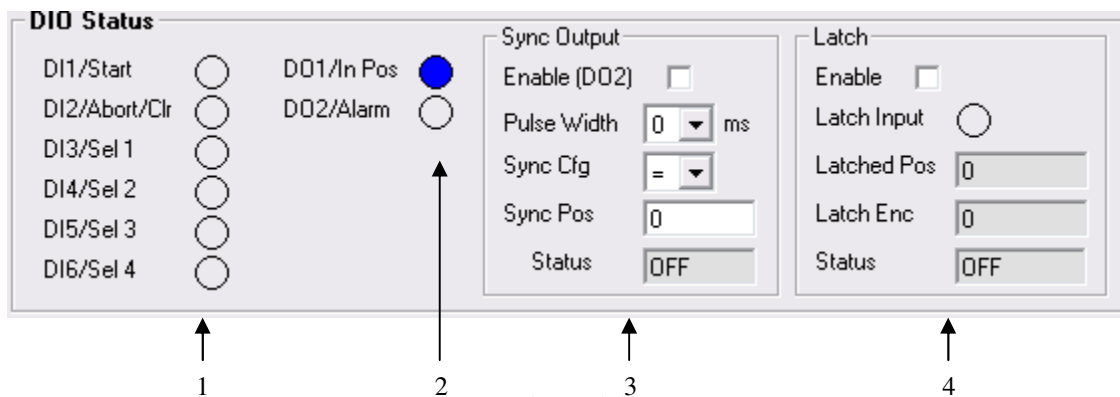

Figure 5.5³

1. **Digital Input Status** – digital inputs can be used for DIO move control or as general purpose use. Refer to the setup screen to disable and enable the DIO

- move control.
2. **Digital Out Status and Control** – digital outs are used for StepNLoop or general purpose output use. When used as general purpose outputs, the outputs can be triggered by clicking on the circle.
 3. **Sync Output** – DO2 can be triggered using the Sync operation.
 4. **Latch** - encoder and pulse positions can be captured/latched with an input trigger.

D. Analog Inputs

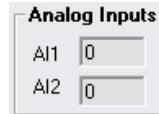

Figure 5.6

Two analog input channels are available for general purpose use or for joystick control use. The analog values are in mV.

E. Product Information

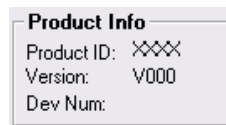

Figure 5.7

Product information and firmware version and device number is displayed. Device number can be changed from the setup screen to support multiple devices on the USB or RS-485 communication.

F. Terminal



Figure 5.8

Terminal dialog box allows manual testing of the commands from a terminal screen as shown in Figure 5.8.

G. Setup

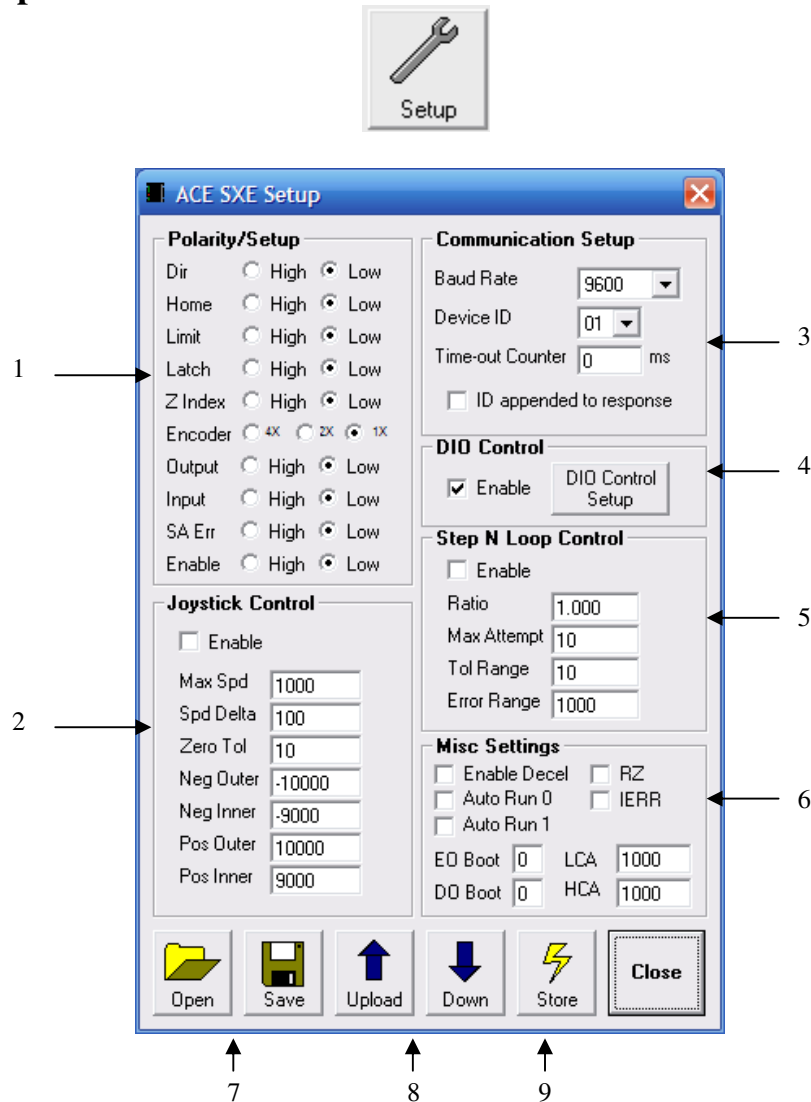

Figure 5.9

1. **Polarity Setup** – the following polarity parameters can be configured
 - Dir: direction of the motion (clockwise or counter-clockwise)
 - Home: home input polarity
 - Limit: limit input polarity
 - Latch: latch input polarity
 - Z-Index: Encoder Z index channel
 - Encoder: encoder multiplication factor can be configured as 1X, 2X, or 4X
 - Output: digital output polarity

- Input: digital input polarity
 - SA Err: stand-alone error jump line.
 - Low: jump to previous line
 - High: jump to line 0
 - Enable: enable output polarity
2. **Joystick Control** – ACE-SXE allows joystick control using the analog input
1. See joystick control section for details of the joystick parameters.
3. **Communication Setup**
- RS-485 communication baud rate can be selected to support different communication speeds.
 - Device ID configuration allows multiple devices on the RS-485 or USB communication network.
 - Time-out counter is a watch-dog timer for communication (ms)
 - ID append to response is used by RS-485 communication for adding the device ID to any response.
4. **DIO Control** – Digital IO motion control allows motion profiles to be triggered through the digital inputs. See DIO motion control section for details. The following dialog box is shown for the DIO motion control.

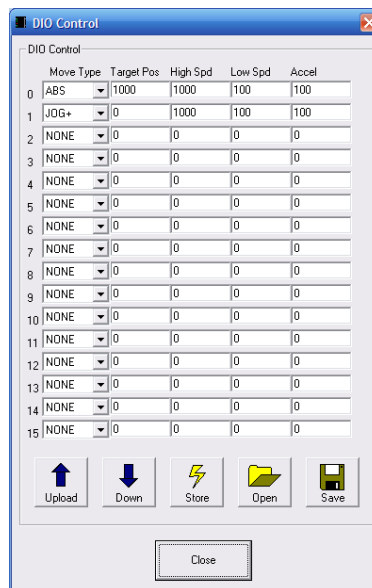

Figure 5.10

5. **StepNLoop Control** – Using the encoder input, StepNLoop control allows closed loop position verification and correction for the moves. See StepNLoop control section for details.
6. **Misc Settings**
- Enable Decel: Allow for unique deceleration and acceleration values
 - Auto Run 0: Run stand-alone program 0 on boot-up.
 - Auto Run 1: Run stand-alone program 1 on boot-up.
 - RZ: Return to zero position after homing routines

- IERR: Ignore limit error
 - EO Boot: Configure enable output boot-up state
 - DO Boot: Configure digital output boot-up state
 - LCA: Set limit correction amount
 - HCA: Set home correction amount
7. **Open/Save** – Configuration values can be saved to a file and read from a file.
 8. **Upload/Download** – Configuration values can be uploaded and downloaded. Note that if the configuration values are changed, they need to be downloaded to take effect.
 9. **Store** – The downloaded parameters can be permanently stored on the non-volatile memory.

H. Standalone Program File Management

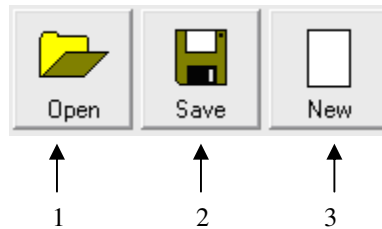

Figure 5.11

1. **Open** – Open standalone program
2. **Save** – Save standalone program
3. **New** – Clear the standalone program editor

I. Standalone Program Editor

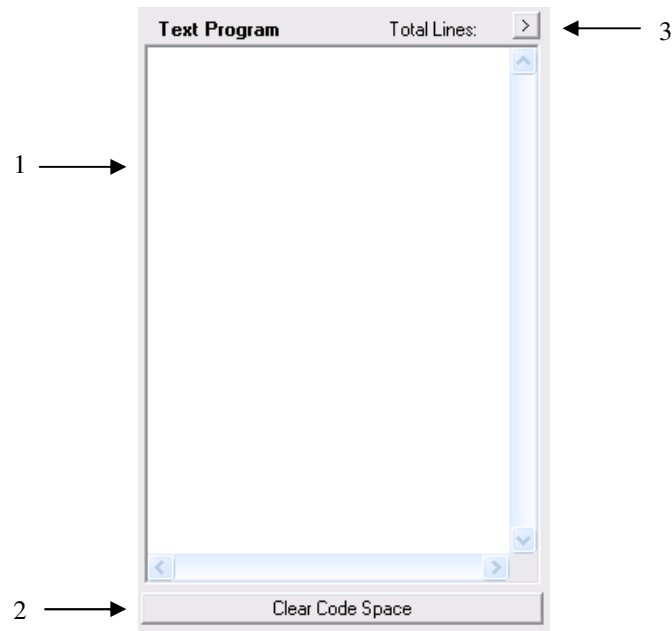

Figure 5.12

1. Write the standalone program in the Program Editor
2. Use this button to remove the current standalone program
3. Use this button to open a larger and easier to manage program editor.

J. Standalone Processing

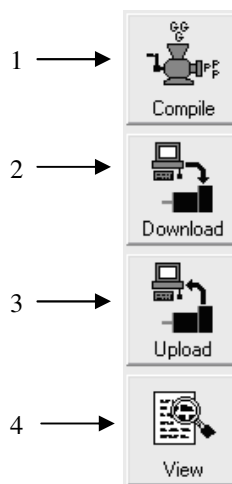

Figure 5.13

1. **Compile** – Compile the standalone program
2. **Download** – Download the compiled program
3. **Upload** – Upload the standalone program from the controller
4. **View** – View the low level compiled program

K. Variable Status

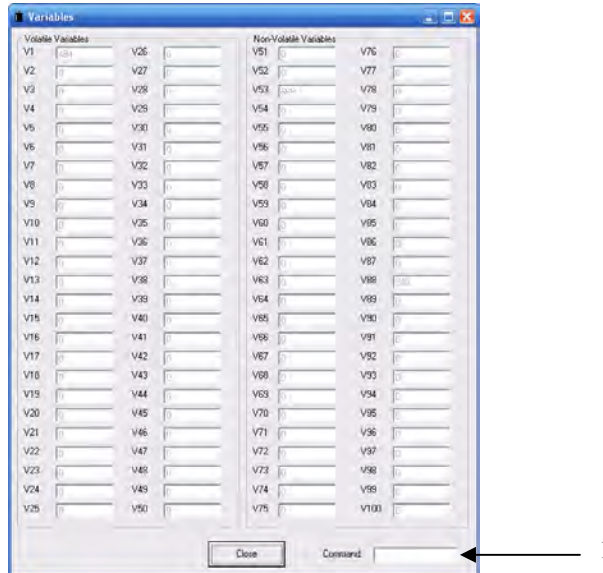

Figure 5.14

View the status of variables 1-100. Note that this window is read-only.

1. **Command line** – To write to variable, use `V[1-100] = [value]` syntax.

L. Program Control

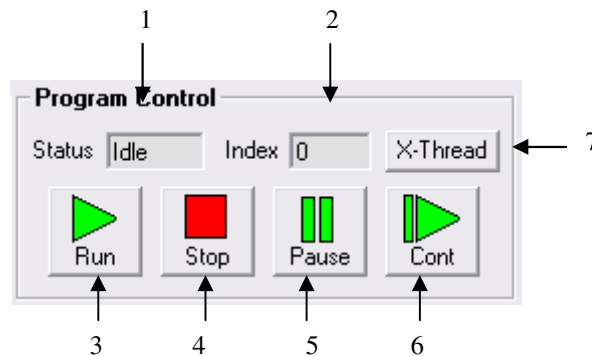

Figure 5.15

1. **Program Status** – program status shows here. Following are possible program status: Idle, Running, Errored and Paused.

2. **Index** – program that is downloaded is in the form of low-level code. Each line of the low level code has a line number which shows here.
3. **Run** – program is run.
4. **Stop** – program is stopped.
5. **Pause** – program that is running can be paused.
6. **Continue** – program that is paused can be continued
7. **X-Thread** – Open the Program Control for standalone multi-thread operation.

M. On-the-fly Speed Change

Set the speed on the fly. On the fly speed change feature can only be used if the controller is already in motion.

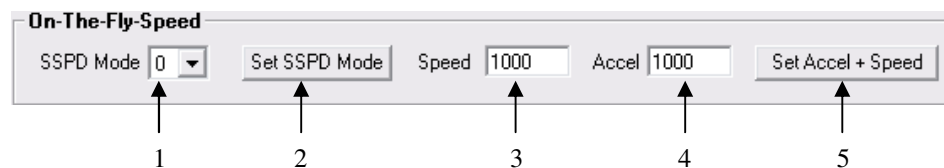

Figure 5.16

1. **On-the-fly speed mode** – Before setting the controller into motion, set the SSPDM parameter. To see which value to use, see the on-the-fly speed change section.
2. **Set SSPDM** – Set the SSPDM parameter. Note that if an on-the-fly speed change operation is to be used, this parameter must be set before the controller starts motion.
3. **Desired Speed** – Once the “Set Speed” button is clicked, the speed will change on-the-fly to the desired speed.
4. **Desired Acc/Dec** – The acceleration/deceleration use for the on-the-fly speed change operation.
5. **Set SSPD[value]** – Start the on-the-fly speed operation

N. About



Figure 5.17

Click this button to display the GUI version as well as the firmware version of the controller/driver. If the firmware version is not up to date, the unsupported features will be listed.

6. Motion Control Overview

Important Note: All the commands described in this section are interactive commands and are not analogous to stand-alone commands. Refer to the “Standalone Language Specification” section for details regarding stand-alone commands.

Motion Profile

By default, a trapezoidal velocity profile is used. See Figure 6.0.

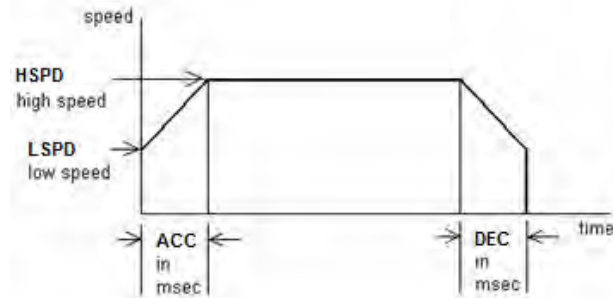

Figure 6.0

High speed and low speed are in pps (pulses/second). Use **HSPD/LSPD** commands to modify the high speed and low speed settings.

Acceleration and deceleration time are in milliseconds. Use the **ACC/DEC** command to modify the acceleration and deceleration values.

S-curve velocity profile can also be achieved by using the **SCV** command. See Figure 6.1.

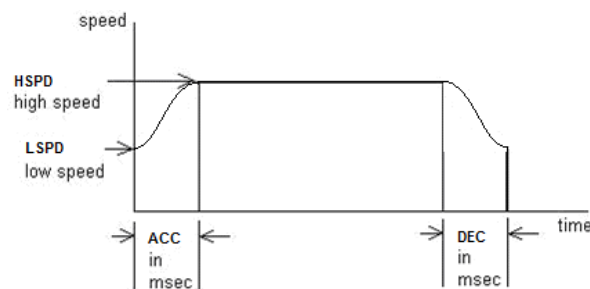

Figure 6.1

Notes:

By default, the deceleration is defined by the value set in the **ACC** parameter. In order to decelerate using the value set in the **DEC** parameter, set **EDEC** to 1.

The minimum and maximum acceleration values depend on the high speed and low speed settings. Refer to Table A.0 and Figure A.0 in **Appendix A** for details.

On-the-fly Speed Change

On-the-fly speed change can be achieved with the **SSPD** command. In order to use the **SSPD** command, s-curve velocity profile must be disabled.

SSPD Mode

The correct speed window must be selected in order to use the SSPD command. To select a speed window, use the **SSPDM** command. Refer to **Appendix A** for details.

During on-the-fly speed change operation, you must keep the initial and destination speeds within the speed window.

For non on-the-fly speed change moves, set **SSPDM=0**.

Analog Inputs

Get the analog input status of the ACE-SXE by using the **AI1** and **AI2** commands. Return value is 0-5000 mV.

Joystick Control

Using analog input 1, speed control using analog input can be done. Analog input of 0V to 2.5V represents negative joystick direction and analog input of 2.5 to 5V represents positive joystick direction. 2.5V represents the zero joystick position. To set tolerance of the zero joystick position, use **JV5** variable. For example, if **JV5** is set to 100, then the zero range for X axis joystick control will be from 2.4V to 2.6V.

Maximum joystick speed is set using **JV1** variable

Summary of joystick control parameters

Command	Description
JV1	X axis Maximum Joystick Speed at 5V and 0V.
JV3	X axis Maximum speed change
JV5	X axis zero tolerance range for analog input

Table 6.0

Maximum speed change (**JV3**) variable affects the maximum amount that the speed can change due to change in analog input.

Joystick control also has soft limit control. Limits are broken down into positive inner and outer limits and negative inner and outer limits. When moving in positive direction, as soon as positive inner limit is crossed, the speed is reduced. If position crosses over the outer limit, the joystick speed is set to zero. Same goes for negative direction and negative limits.

Summary of joystick soft limit parameters

Command	Description
JL1	X axis Negative Outer Soft Limit
JL2	X axis Negative Inner Soft Limit
JL3	X axis Positive Inner Soft Limit
JL4	X axis Positive Outer Soft Limit

Table 6.1

To enable joystick control use **JO** command. The disable joystick control use **JF** command or **ABORT** command.

The behavior of the limits of the joystick control is explained by Figure 6.2.

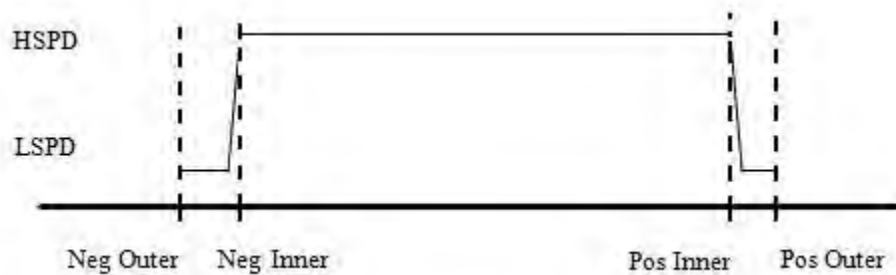

Figure 6.2

Digital Inputs / Outputs

ACE-SXE module comes with 6 digital inputs and 2 digital outputs which can be used for DIO control. When DIO control is disabled, these can be used as general digital outputs. Enable/disable DIO control mode by using the **EDIO** command.

Inputs

Read digital input status using the **DI** command.

Digital input values can also be referenced one bit at a time by the **DI[1-6]** commands. Note that the indexes are 1-based for the bit references (i.e. DI1 refers to bit 0, not bit 1)

Bit	Description	Bit-Wise Command
0	Digital Input 1 (Start)	DI1
1	Digital Input 2 (Abort/Clear)	DI2
2	Digital Input 3 (Select 1)	DI3
3	Digital Input 4 (Select 2)	DI4
4	Digital Input 5 (Select 3)	DI5
5	Digital Input 6 (Select 4)	DI6

Table 6.2

If a digital input is on (i.e. input is pulled to GND of opto-supply), the bit status is 0. Otherwise, the bit status is 1.

Outputs

When DIO control is disabled, you can drive DO1 and DO2 by using the **DO** command. DO value must be within the range of 0-3.

Digital output values can also be referenced one bit at a time by the **DO[1-2]** commands. Note that the indexes are 1-based for the bit references (i.e. DO1 refers to bit 0, not bit 1)

Bit	Description	Bit-Wise Command
0	Digital Output 1 (In Position)	DO1
1	Digital Output 2 (Alarm)	DO2

Table 6.3

When DIO control is enabled, DO1 and DO2 are used as In Position and Alarm outputs.

If digital output is turned on (i.e. the output is pulled to GND), the bit status is 1. Otherwise, the bit status is 0.

The initial state of both digital outputs can be defined by setting the **DOBOOT** register to the desired initial digital output value. The value is stored to flash memory once the **STORE** command is issued.

Motor Power

Using the **EO** command, the motor power can be enabled or disabled. By default, the enable output is turn on at boot-up.

The initial state of the Enable Output can be defined by setting the **EOBOOT** register to the desired initial digital output value. The value is stored to flash memory once the **STORE** command is issued.

Polarity

Using the **POL** command, polarity of following signals can be configured:

Bit	Description
0	Reserved
1	Direction
2	Reserved
3	Reserved
4	Limit
5	Home
6	Latch

7	Z-channel index	
8,9	Encoder decoding	
	00	1X
	01	2X
	10	4X
10	Digital Output	
11	Digital Input	
12	Jump to line 0 on error†	
13	Enable Output	

Table 6.4

†Used for error handling within standalone operation. If this bit is on, the line that is executed after SUB31 is called will be line 0. Otherwise, it will be the line that caused the error.

Positional Moves

ACE-SXE can operate in either incremental or absolute move modes. Use **X** command to make moves. Use the **INC** and **ABS** commands the change the move mode. Use **MM** command to read the current move mode.

Note: If a motion command is sent while the controller is already moving, the command is not processed. Instead, an error response is returned.

On-The-Fly Target Position Change

On-the-fly target position change can be achieved using the **T[value]** command. While the motor is moving, **T[value]** will change the final destination of the motor. If the motor has already passed the new target position, it will reverse direction once the target position change command is issued.

Note: If a **T** command is sent while the controller is not performing a target move, the command is not processed. Instead, an error response is returned.

Jogging

Jogging is available for continuous speed operation. Use **J+** and **J-** commands to jog in positive or negative direction.

Stopping Motor

When motor is moving, jogging, or homing, using the **ABORT** command will immediately stop the motor. Using the **STOP** command will decelerate the motor to low speed and then stop.

Homing

Home search sequence involves moving the motor towards the home or limit switches and then stopping when the relevant input is detected. The ACE-SXE has five different homing routines:

Home Input Only (High speed only)

Use the **H+/H-** command. Figure 6.5 shows the homing routine.

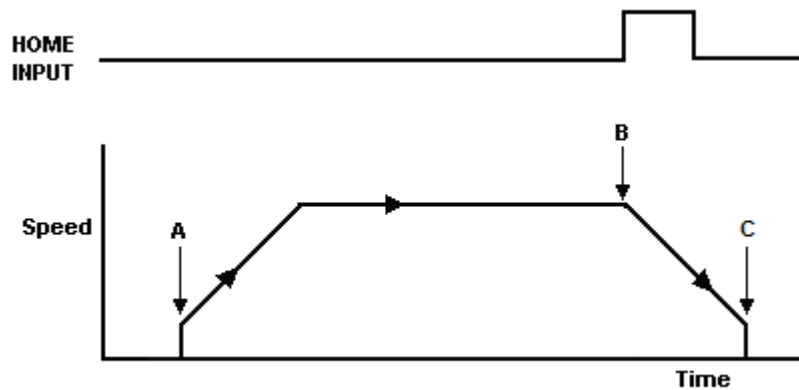

Figure 6.5

- A. Starts the motor from low speed and accelerates to high speed.
- B. As soon as the home input is triggered, the position counter is reset to zero and the motor begins to decelerate to low speed. As the motor decelerates, the position counter keeps counting with reference to the zero position.
- C. Once low speed is reached, the motor stops. The position is non-zero.

Home Input Only (High speed and low speed)

Use the **HL+/HL-** command. Figure 6.6 shows the homing routine.

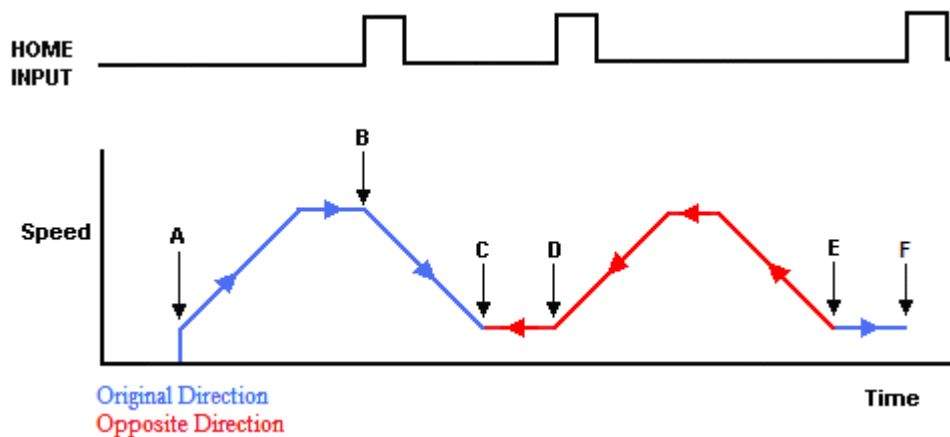

Figure 6.6

- A. Starts the motor from low speed and accelerates to high speed.

- B. As soon as the home input is triggered, the position counter is reset to zero and the motor decelerates to low speed.
- C. Once low speed is reached, the motor reverses direction to search for the home switch.
- D. Once the home switch is reached, it will continue past the home switch by the amount defined by the home correction amount (**HCA**) at high speed.
- E. The motor is now past the home input by the amount defined by the home correction amount (**HCA**). The motor now moves back towards the home switch at low speed.
- F. The home input is triggered again, the position counter is reset to zero and the motor stops immediately

Limit Only

Use the **L+/L-** command. Figure 6.7 shows the homing routine.

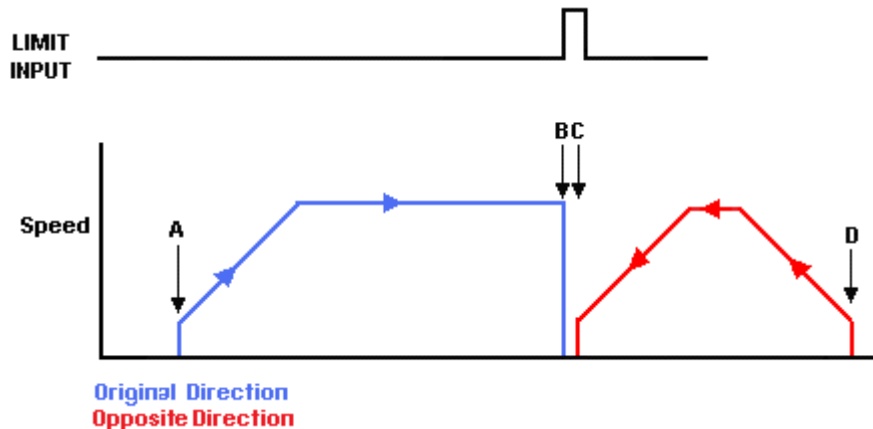

Figure 6.7

- A. Issuing a limit home command starts the motor from low speed and accelerates to high speed.
- B. The corresponding limit is triggered and the motor stops immediately.
- C. The motor reverses direction by the amount defined by the limit correction amount (**LCA**) at high speed.
- D. The zero position is reached.

Home and Z-index

Figure 6.8 shows the homing routine.

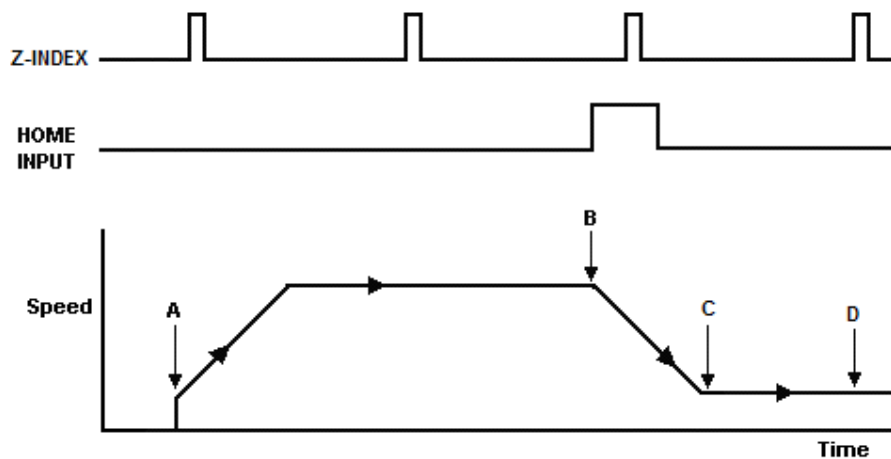

Figure 6.8

- A. Issuing a limit home command starts the motor from low speed and accelerates to high speed.
- B. As soon as the home input is triggered, the motor decelerates to low speed
- C. Once low speed is reached, the motor begins to search for the z-index pulse.
- D. Once the z-index pulse is found, the motor stops and the position is set to zero.

Z-index only

Figure 6.9 shows the homing routine.

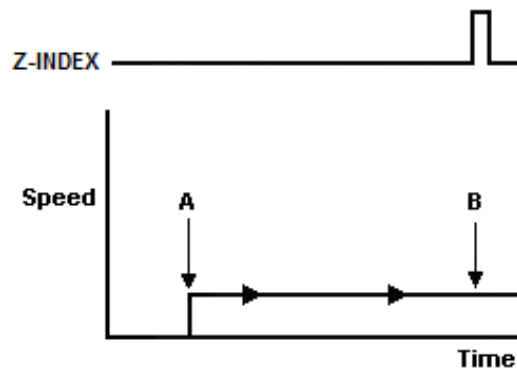

Figure 6.9

- A. Issuing a limit home command starts the motor at low speed.
- B. Once the z-index pulse is found, the motor stops and the position is set to zero.

Note: For **H** and **HL** homing routines, it is possible to have the motor automatically return to the zero position. To do so, set the **RZ** register to 1.

Motor Position

Motor position can be set and read by using the **PX** command.
Encoder position can be set and read by using the **EX** command.

Motor Status

Motor status can be read anytime by reading the response to the **MST** command. The following is the bit representation of motor status:

Bit	Description
0	Motor running at constant speed
1	Motor in acceleration
2	Motor in deceleration
3	Home input switch status
4	Minus limit input switch status
5	Plus limit input switch status
6	Minus limit error. This bit is latched when minus limit is hit during motion. This error must be cleared using the CLR command before issuing any subsequent move commands.
7	Plus limit error. This bit is latched when plus limit is hit during motion. This error must be cleared using the CLR command before issuing any subsequent move commands.
8	Latch input status
9	Z-index status
10	TOC time-out status

Table 6.5

Examples:

- When motor status value is 0, motor is idle and all input switches are off.
- When motor status value is 2, motor is in acceleration.
- When motor status value is 9, motor is moving in constant high speed and home input switch is on.
- When motor status value is 64, motor is in minus limit error. Use **CLR** command to clear the error before issuing any more move commands.

Limit Inputs

If positive limit switch is triggered while moving in positive direction, the motor will immediately stop and the motor status bit for positive limit error is set. The same is for the negative limit while moving in the negative direction. Once the limit error is set, use the **CLR** command to clear the error. Once the error is cleared, move the motor out of the limit switch.

The limit error state can be ignored by setting **IEERR**=1. In this case, the motor will still stop when the limit switch is triggered; however, it will not enter an error state.

Latch Input

The ACE-SXE module provides a high speed position latch input.

This input performs high speed position capture of both pulse and encoder positions but does not reset the pulse or encoder position counters.

Note: When StepNLoop mode is enabled, the position value should be ignored.

Use the **LT** command to enable and disable latch feature. To read the latch status, use **LTS** command.

Following are return value description for **LTS** command.

Return Value	Description
0	Latch off
1	Latch on and waiting for latch trigger
2	Latch triggered

Table 6.6

Once the latch is triggered, the triggered position can be retrieved using **LTP** (latched pulse position) and **LTE** (latched encoder position) commands.

StepNLoop Closed Loop Control

ACE-SXE features a closed-loop position verification algorithm called StepNLoop (SNL). The algorithm requires the use of an incremental encoder.

SNL performs the following operations:

- 1) **Position Verification:** At the end of any targeted move, SNL will perform a correction if the current error is greater than the tolerance value.
- 2) **Delta Monitoring:** The delta value is the difference between the actual and the target position. When delta exceeds the error range value, the motor is stopped and the SNL Status goes into an error state. Delta monitoring is performed during moves – including homing and jogging. To read the delta value, use the **DX** command.

See Table 6.7 for a list of the SNL control parameters.

SNL Parameter	Description	Command
StepNLoop Ratio	†Ratio between motor pulses and encoder counts. This ratio will depend on the motor type, micro-stepping, encoder resolution and decoding multiplier. Value must be in the range [0.001 , 999.999].	SLR
Tolerance	Maximum error between target and actual position that is considered “In Position”. In this case, no correction is performed. Units are in encoder counts.	SLT

Error Range	Maximum error between target and actual position that is not considered a serious error. If the error exceeds this value, the motor will stop immediately and go into an error state.	SLE
Correction Attempt	Maximum number of correction tries that the controller will attempt before stopping and going into an error state.	SLA

Table 6.7

†A convenient way to find the StepNLoop ratio is to set EX=0, PX=0 and move the motor +1000 pulses. The ratio can be calculated by dividing 1000 by the resulting EX value. Note that the value must be positive. If it is not, then the direction polarity must be adjusted. See Table 6.4 for details.

To enable/disable the SNL feature use the **SL** command. To read the SNL status, use **SLS** command to read the status.

See Table 6.8 for a list of the **SLS** return values.

Return Value	Description
0	Idle
1	Moving
2	Correcting
3	Stopping
4	Aborting
5	Jogging
6	Homing
7	Z-Homing
8	Correction range error. To clear this error, use CLRS or CLR command.
9	Correction attempt error. To clear this error, use CLRS or CLR command.
10	Stall Error. DX value has exceeded the correction range value. To clear this error, use CLRS or CLR command.
11	Limit Error
12	N/A (i.e. SNL is not enabled)
13	Limit homing

Table 6.8

See Table 6.9 for SNL behavior within different scenarios.

Condition	SNL behavior (motor is moving)	SNL behavior (motor is idle)
$\delta \leq \text{SLT}$	Continue to monitor the DX	In Position. No correction is performed.
$\delta > \text{SLT}$ AND $\delta < \text{SLE}$	Continue to monitor the DX	Out of Position. A correction is performed.
$\delta > \text{SLT}$ AND $\delta > \text{SLE}$	Stall Error. Motor stops and signals and error.	Error Range Error. Motor stops and signals and error.
Correction Attempt > SLA	NA	Max Attempt Error. Motor stops and signals and error.

Table 6.9

Key

- [δ]: Error between the target position and actual position
- SLT: Tolerance range
- SLE: Error range
- SLA: Max correction attempt

Notes:

Once SNL is enabled, position move commands are in term of encoder position. For example, X1000 means to move the motor to encoder 1000 position.

Once SNL is enabled, the speed is in encoder speed. For example HSPD=1000 when SNL is enabled means that the target high speed is 1000 encoder counts per second.

If DIO mode is on while SNL is enabled, DO1 is dedicated as the “In Position” output and DO2 is dedicated as the “Alarm” output. In order to use the digital outputs for general purpose, disable DIO by setting **EDIO=0**.

Device Number

ACE-SXE module provides the user with the ability to modify the unique device number. In order to make these changes, first store the desired number using the **DN** command. Note that this value must be within the range [SXE01,SXE99].

To write the values to the device’s flash memory, use the **STORE** command. After a complete power cycle, the new device number will be written to memory. Note that before a power cycle is completed, the settings will not take effect.

By default: Device name is set to: **SXE01**

Baud Rate Setting

ACE-SXE provides the user with the ability to set the desired baud rate of the serial communication. In order to make these changes, first store the desired baud rate by using the **DB** command.

Return Value	Description
1	9600
2	19200
3	38400
4	57600
5	115200

Table 6.10

To write the values to the device's flash memory, use the **STORE** command. After a complete power cycle, the new device number will be written to memory. Note that before a power cycle is completed, the settings will not take effect.

By default: Baud rate is set to: **1 (9600 bps)**

Sync Output

ACE-SXE has a designated synchronization digital output (DO2). The synchronization signal output is triggered when the encoder position value meets the set condition.

While this feature is enabled, the designated digital output (DO2) cannot be controlled by user.

Use **SYNO** to enable the synchronization output feature.

Use **SYNF** to disable the synchronization output feature.

Use **SYNP** to read and set the synchronization position value. (28-bit signed number)

Use **SYNC** to set the synchronization condition.

- 1 – Turn the output on when the encoder position is **EQUAL** to sync position.
If the synchronization output is done during motion, the sync output pulse will turn on only when the encoder position and sync position are equal.
- 2 – Turns output on when the encoder position is **LESS** than the sync position.
- 3 – Turns output on when the encoder position is **GREATER** than sync position.

Use **SYNT** to set the pulse width output time (ms). This parameter is only used if the synchronization condition is set to 1. Note the maximum pulse width is 10 ms. If this parameter is set to 0, the output pulse will depend on how long the encoder value is equal to the sync position.

Use **SYNS** to read the synchronization output status.

- 0 – Sync output feature is off
- 1 – Waiting for sync condition
- 2 – Sync condition occurred

When sync output feature is first enabled, the digital output turns on (i.e. the output is pulled to GND and DO2=1). Once sync output is triggered, the digital output turns off (i.e. the output is pulled to Vs and DO2=0).

Broadcasting over RS-485

The address '00' is reserved for broadcasting over an RS-485 bus. Any ASCII command prefixed by '@00' will be processed by all ACE-SXE modules on the RS-485 bus. When a broadcast command is received by an ACE-SXE module, no response is sent back to the master.

Response type selection

It is possible to choose between two types of response string formats. This parameter can be set using the **RT** command.

Format 1 (default): [Response][CR]

Examples:

For querying the encoder position

Send: @01EX[CR]

Reply: 1000[CR]

For jogging the motor in positive direction

Send: @01J+[CR]

Reply: OK[CR]

To achieve this response string type, send command **RT=0**.

Format 2: #[DeviceName][Response][CR]

Examples:

For querying the encoder position

Send: @01EX[CR]

Reply: #011000[CR]

For jogging the motor in positive direction

Send: @01J+[CR]

Reply: #01OK[CR]

To achieve this response string type, send command **RT=1**.

To write the response type parameter to flash memory, use the STORE command. After a complete power cycle, the new response type will take effect. Note that before a power cycle is done, the setting will not take effect.

Standalone Programming

Standalone Program Specification:

Memory size: 1785 assembly lines ~ 10.5 KB.

Note: Each line of pre-compiled code equates to 1-4 lines of assembly lines.

WAIT Statement: When writing a standalone program, it is generally necessary to wait until a motion is completed before moving on to the next line. In order to do this, the WAIT statement must be used. See the examples below:

In the example below, the variable V1 will be set immediately after the X10000 move command begins; it will not wait until the controller is idle.

```
X10000          ;* Move to position 0
V1=100
```

Conversely, in the example below, the variable V1 will not be set until the motion has been completed. V1 will only be set once the controller is idle.

```
X10000          ;* Move to position 0
WAITX          ;* Wait for the move to complete
V1=100
```

Multi-Threading: The ACE-SXE supports the simultaneous execution of two standalone programs. Program 0 is controlled via the **SR0** command and program 1 is controlled via the **SR1** command. For examples of multi-threading, please refer to the **Example Standalone Programs** section.

Note: Sub-routines can be shared by different threads.

Error Handling: If an error occurs during standalone execution (i.e. limit error), the program automatically jumps to SUB 31. If SUB 31 is NOT defined, the program will cease execution and go to error state. If SUB 31 is defined by the user, the code within SUB 31 will be executed. The return jump line will be determined by bit 12 of the **POL** register. See Table 6.4 for details.

Calling subroutines over communication: Once a subroutine is written into the flash, they can be called via USB communication using the **GS** command. The subroutines are referenced by their subroutine number [0-31]. If a subroutine number is not defined, the controller will return with an error.

Standalone Run on Boot-Up: Standalone can be configured to run on boot-up using the **SLOAD** command. See description in Table 6.12:

Bit	Description
0	Standalone Program 0
1	Standalone Program 1

Table 6.12

Note: DIO communication is not allowed while a standalone programming is running. If DIO communication is enabled while a standalone program begins execution, DIO communication will be automatically disabled.

Communication Time-out Feature (Watchdog)

ACE-SXE allows for the user to trigger an alarm if the master has not communicated with the device for a set period of time. When an alarm is triggered bit 10 of the **MST** parameter is turned on. The time-out value is set by the **TOC** command. Units are in milliseconds. This feature is usually used in stand-alone mode. Refer to the **Example Stand-alone Programs** section for an example.

In order to disable this feature set **TOC=0**.

Storing to Flash

The following items are stored to flash:

ASCII Command	Description
DB	Serial communication baud rate
DN	Device name
DNM	†Modbus device number
DOBOOT	DO configuration at boot-up
EDEC	Unique deceleration enable
EDIO, MP	DIO communication settings
EOBOOT	EO configuration at boot-up
HCA	Home correction amount
IERR	Ignore limit error enable
JO, JF, JV1, JV3, JV5, JL1-4	Joystick settings
LCA	Limit correction amount
POL	Polarity settings
RSM	†Modbus enable
RT	ASCII response type
RZ	Return to zero position after homing
SL, SLR, SLE, SLT, SLA	StepNLoop parameters
SLOAD	Standalone program run on boot-up parameter
TOC	Time-out counter reset value
V51-V100	Note that on boot-up, V1-V50 are reset to value 0

Table 6.13

† See “Modbus_Addition_Addendum_A” document for details.

Note: When a standalone program is downloaded, the program is immediately written to flash memory.

7. Communication – USB

ACE-SXE USB communication is USB 2.0 compliant.

Communication between the PC and ACE-SXE is done using Windows compatible DLL API function calls as shown below. Windows programming language such as Visual BASIC, Visual C++, LABView, or any other programming language that can use DLL can be used to communicate with the Performax module.

Typical communication transaction time between PC and ACE-SXE for sending a command from a PC and getting a reply from ACE-SXE using the **fnPerformaxComSendRecv()** API function is in single digit milliseconds. This value will vary with CPU speed of PC and the type of command.

USB Communication API Functions

For USB communication, following DLL API functions are provided.

BOOL fnPerformaxComGetNumDevices(OUT LPDWORD lpNumDevices);

- This function is used to get total number of all types of Performax and Performax USB modules connected to the PC.

**BOOL fnPerformaxComGetProductString(IN DWORD dwNumDevices,
OUT LPVOID lpDeviceString,
IN DWORD dwOptions);**

- This function is used to get the Performax or Performax product string. This function is used to find out Performax USB module product string and its associated index number. Index number starts from 0.

**BOOL fnPerformaxComOpen(IN DWORD dwDeviceNum,
OUT HANDLE* pHandle);**

- This function is used to open communication with the Performax USB module and to get communication handle. dwDeviceNum starts from 0.

BOOL fnPerformaxComClose(IN HANDLE pHandle);

- This function is used to close communication with the Performax USB module.

**BOOL fnPerformaxComSetTimeouts(IN DWORD dwReadTimeout,
DWORD dwWriteTimeout);**

- This function is used to set the communication read and write timeout. Values are in milliseconds. This must be set for the communication to work. Typical value of 1000 msec is recommended.

BOOL fnPerformaxComSendRecv(IN HANDLE pHandle,

```

IN LPVOID wBuffer,
IN DWORD dwNumBytesToWrite,
IN DWORD dwNumBytesToRead,
OUT LPVOID rBuffer);

```

- This function is used to send command and get reply. Number of bytes to read and write must be 64 characters.

BOOL *fnPerformaxComFlush*(IN HANDLE pHandle)

- Flushes the communication buffer on the PC as well as the USB controller. It is recommended to perform this operation right after the communication handle is opened.

USB Communication Issues

A common problem that users may have with USB communication is that after sending a command from the PC to the device, the response is not received by the PC until another command is sent. In this case, the data buffers between the PC and the USB device are out of sync. Below are some suggestions to help alleviate this issue.

- 1) **Buffer Flushing:** If USB communication begins from an unstable state (i.e. your application has closed unexpectedly, it is recommended to first flush the USB buffers of the PC and the USB device. See the following function prototype below:

BOOL *fnPerformaxComFlush*(IN HANDLE pHandle)

Note: *fnPerformaxComFlush* is only available in the most recent PerformaxCom.dll which is not registered by the standard USB driver installer. A sample of how to use this function along with this newest DLL is available for download on the website

- 2) **USB Cable:** Another source of USB communication issues may come from the USB cable. Confirm that the USB cable being used has a noise suppression choke. See photo below:



Figure 7.0

8. Communication – RS-485 (ASCII)

When communicating on RS-485 (ASCII), it is recommended to add 120 Ohm terminating resistor between 485+ and 485- signal on the last module.

Communication Port Settings

Parameter	Setting
Byte Size	8 bits
Parity	None
Flow Control	None
Stop Bit	1

Table 8.0

ASCII Protocol

Sending Command

ASCII command string in the format of
@[DeviceName][ASCII Command][CR]

[CR] character has ASCII code 13.

Receiving Reply

The response will be in the format of
[Response][CR]

[CR] character has ASCII code 13.

Examples:

For querying the x-axis polarity

Send: @00POL[CR]
Reply (if RT=0): 7[CR]
Reply (if RT=1): #007[CR]

For jogging the x-motor in positive direction

Send: @00J+[CR]
Reply (if RT=0): OK[CR]
Reply (if RT=1): #00OK[CR]

For aborting any motion in progress

Send: @00ABORT[CR]
Reply (if RT=0): OK[CR]
Reply (if RT=1): #00OK[CR]

Note: RT is a parameter that sets the response type of the device.

9. Communication - DIO

DIO communication allows the user to store 16 different types (see Table 9.1) of moves into ACE-SXE flash memory. These moves can be referenced using the **select bits (DI3-DI6)** and triggered by using the **start bit (DI1)**. Motion can be aborted by triggering the **abort/clear bit (DI2)**. If an error occurs, it can also be cleared by triggering the **abort/clear bit (DI2)**.

DIO Latency

Digital input response time to a trigger from **start bit (DI1)** is about 10 micro seconds. The actual amount of time from trigger to the beginning of the motion move depends on the command.

Setting Up DIO Parameters

In order to use this feature, you must first enable DIO mode (using **EDIO** command) as well as configure the appropriate DIO parameters via USB.

The DIO parameters are set using the **MP[X][Y]** command.

To view parameters, use command **MP[X][Y]**. To set values, use **MPXY=[value]**.

X Parameter:

This parameter corresponds to the $2^4=16$ selections that can be selected by DI3-DI6. This character must be written in hexadecimal (i.e. 0-F).

Y Parameter:

This parameter corresponds to the 5 different values that correspond to each DIO move. See the table below.

Note that some move operations do not need all 5 parameters. In this case, any extra move values that are entered will be ignored. For example, the STOP command does not need a “Target Position”. Any value entered here will be ignored in this case.

Y Parameter

Y	Description
0	DIO Move reference (see Table 9.1)
1	Target Position
2	Low Speed
3	Acceleration
4	High Speed

Table 9.0

DIO Move List

Move Reference	Command
0	None
1	STOP
2	X[Target Position]
3	INC+ [Current Position + Target Position]
4	INC- [Current Position - Target Position]
5	J+
6	J-
7	H+
8	H-
9	EO=0
10	EO=1
11	ZH+
12	ZH-
13	SSPD[High Speed]
14	SCV=1
15	SCV=0
16	SL=1
17	SL=0
18	PX=[Target Position]
19	EX=[Target Position]
20	Z+
21	Z-
22	SSPDM=[High Speed]

Table 9.1

Examples

- 1. Make DIO selection “0” correspond to the J+ command with the following parameters:**

Target Position = NA
 Low Speed = 100
 Acceleration = 300
 High Speed = 1000

Send commands:

MP00 = 5 ` Set move reference for “0” to J+
 MP01 = 0 ` Set target position to 0 (value will be ignored)
 MP02 = 100 ` Set low speed to 100

MP03 = 300 ` Set acceleration to 300
 MP04 = 1000 ` Set high speed to 1000

2. **Make DIO selection “0xF” correspond to the X800 command with the following parameters:**

Target Position = 800
 Low Speed = 500
 Acceleration = 500
 High Speed = 5000

Send commands:

MPF0 = 2 ` Set move reference for “F” to X[value]
 MPF1 = 800 ` Set target position to 800
 MPF2 = 500 ` Set low speed to 500
 MPF3 = 500 ` Set acceleration to 500
 MPF4 = 5000 ` Set high speed to 5000

Using DIO

1. First drive the **select bits (DI3-DI6)**.
2. Then pull **start bit (DI1)** low to begin the move. (falling-edge triggered)
3. Trigger **abort/clear bit (DI2)** to abort motion command if desired.

Figure 9.0 shows a timing diagram using DIO control.

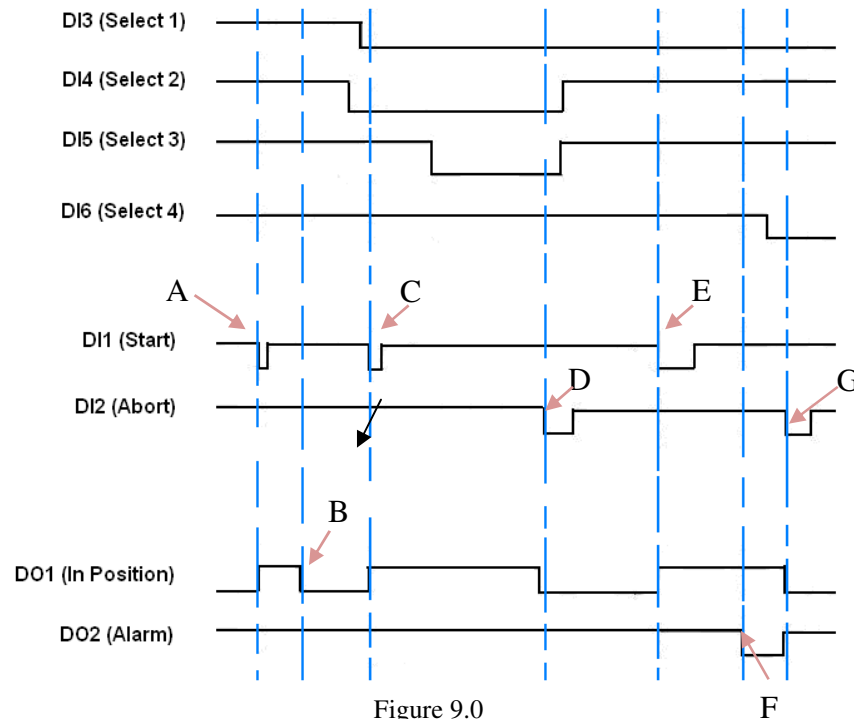

Figure 9.0

- A) On falling edge of **Start**, motion command stored in memory location 0 (0000) is triggered. **In Position** turns off.
- B) After motion command 0 (0000) is complete, **In Position** turn on.
- C) On falling edge of **Start**, motion command stored in memory location 12 (1100) is triggered. **In Position** turns off.
- D) On falling edge of **Abort**, motion stops immediately. **In Position** turns on. Note: If move was an absolute move type, and target position was not reached, **In Position** will instead remain off.
- E) On falling edge of **Start**, motion command stored in memory location 8 (1000) is triggered. **In Position** turns off.
- F) Motion error occurs (i.e. limit error or StepNLoop error). **Alarm** turns on. **In Position** stays off. Controller is now in error state.
- G) On falling edge of **Abort**, error state is cleared. **In Position** turns on.

Notes:

DIO communication is not allowed while a standalone programming is running. If DIO communication is enabled while a standalone program begins execution, DIO communication will be automatically disabled.

Triggering the **start bit (DI1)** will not trigger a motion move if the **abort bit (DI2)** is on, or if the controller is in error state. If the controller is in error state, first clear the error by triggering the **abort/clear bit (DI2)**.

The alarm bit output is on whenever there is either a SNL or limit error.

The in position bit output is on whenever the motor is in position.

Signals are active low.

10. ASCII Language Specification

Important Note: All the commands described in this section are interactive commands and are not analogous to stand-alone commands. Refer to the “Standalone Language Specification” section for details regarding stand-alone commands.

ACE-SXE language is case sensitive. All command should be in capital letters. Invalid command is returned “?”. Always check for proper reply when command is sent.

For **USB communication**, send commands identical to the ones in the following table.

For **RS-485 ASCII communication**, append “@XX” to the command before sending, where “XX” is the device number. Ex: To send the “J+” command to device number 05, send the following: “@05J+”

Command	Description	Return
ABORT	Immediately stops the motor if in motion. For decelerate stop, use STOP command. This command can also be used to clear a StepNLoop error	OK
ABS	Set move mode to absolute	OK
ACC	Returns current acceleration value in milliseconds.	Milli-seconds
ACC=[Value]	Sets acceleration value in milliseconds. Example: ACC=300	OK
AI1, AI2	Get analog input status (0-5000 mV)	Milli-volts
CLR	Clears limit error as well as StepNLoop error	OK
CLRS	Clears StepNLoop error. Note CLR also clears a StepNLoop error	OK
DB	Return the current baud rate of the device	See Table 6.10
DB=[Value]	Set the baud rate of the device	OK
DEC	Get deceleration value in milliseconds. Only used if EDEC=1	Milli-seconds
DEC=[Value]	Set deceleration value in milliseconds. Only used if EDEC=1	OK
DI	Return status of digital inputs	See Table 6.2
DI[1-6]	Get individual bit status of digital inputs	0,1
DO	Return status of digital outputs	2-bit number
DO=[Value]	Set digital output 2 bit number. Digital output is writable only if DIO is disabled.	OK
DO[1-2]	Get individual bit status of digital outputs	See Table 6.3
DO[1-2]=[Value]	Set individual bit status of digital outputs	OK
DOBOOT	Get DO boot-up state	See Table 6.3
DOBOOT=[Value]	Set DO boot-up state	OK
DN	Get device name	[SXE01-SXE99]
DN=[Value]	Set device name	OK
DNM	Get Modbus device number	1-127
DNM=[Value]	Set Modbus device number	OK
DX	Returns the delta value during StepNLoop control	28-bit number
EDEC	Get unique deceleration enable	0 or 1
EDEC=[Value]	Set unique deceleration enable	OK
EDIO	Returns DIO mode status	1 – DIO enabled

		0 – DIO disabled
EDIO=[0 or 1]	Enables (value 1) or disable (value 0) DIO communication	OK
EO	Returns driver power enable.	1 – Motor power enabled 0 – Motor power disabled
EO=[0 or 1]	Enables (1) or disable (0) motor power.	OK
EOBOOT	Get EO boot-up state	0 or 1
EOBOOT=[Value]	Set EO boot-up state	OK
EX	Returns current encoder counter value	28-bit number
EX=[Value]	Sets the current encoder counter value	OK
GS[0-31]	Call a subroutine that has been previously stored to flash memory	OK
HSPD	Returns High Speed Setting	PPS
HSPD=[Value]	Sets High Speed.	OK
H+	Homes the motor in positive direction	OK
H-	Homes the motor in negative direction	OK
HCA	Returns the home correction amount	28-bit number
HCA=[Value]	Sets the home correction amount.	OK
HL+	Homes the motor in positive direction (with with low speed)	OK
HL-	Homes the motor in negative direction (with low speed)	OK
ID	Returns product ID	Ace-Series-SXE
IERR	Get ignore limit error enable	0 or 1
IERR=[Value]	Set ignore limit error enable	OK
INC	Set move mode to incremental	OK
J+	Jogs the motor in positive direction	OK
J-	Jogs the motor in negative direction	OK
JF	Disable joystick control for analog input 1	OK
JV1	Get max speed for joystick control	28-bit number
JV1=[Value]	Set max speed for joystick control	OK
JV3	Get max speed delta for joystick control	28-bit number
JV3=[Value]	Set max speed delta for joystick control	OK
JV5	Get zero speed tolerance for joystick control	28-bit number
JV5=[Value]	Set zero speed tolerance for joystick control	OK
JL1	Get negative outer limit for joystick control	28-bit number
JL1=[Value]	Set negative outer limit for joystick control	OK
JL2	Get negative inner limit for joystick control	28-bit number
JL2=[Value]	Set negative inner limit for joystick control	OK
JL3	Get positive inner limit for joystick control	28-bit number
JL3=[Value]	Set positive inner limit for joystick control	OK
JL4	Get positive outer limit for joystick control	28-bit number
JL4=[Value]	Set positive outer limit for joystick control	OK
JO	Enable joystick control for analog input 1	OK
JS	Get joystick enable status	0 – joystick operation off 1 – joystick operation on
L+	Limit homing in positive direction	OK
L-	Limit homing in negative direction	OK
LCA	Returns the limit correction amount	28-bit number
LCA=[Value]	Sets the limit correction amount.	OK
LSPD	Returns Low Speed Setting	PPS
LSPD=[Value]	Sets Low Speed	OK
LT=[0 or 1]	Enable or disable position latch feature	OK
LTE	Returns latched encoder position	28-bit number

LTP	Returns latched pulse position	28-bit number
LTS	Returns latch status.	See Table 6.6
MM	Get move mode status	0 – Absolute move mode 1 – Incremental move mode
MST	Returns motor status	See Table 6.5
MPXX	Get DIO parameter	
MPXX=[Value]	Set DIO parameter	OK
POL	Returns current polarity	See Table 6.4
POL=[value]	Sets polarity.	OK
PS	Returns current pulse speed	PPS
PX	Returns current position value	28-bit number
PX=[value]	Sets the current position value	OK
RSM	Get Modbus enable	0 or 1
RSM= [0 or 1]	Set Modbus enable	OK
RT	Get response type value	0 or 1
RT= [0 or 1]	Set response type value	OK
RZ	Get return zero enable. Used during homing	0 or 1
RZ=[0 or 1]	Set return zero enable. Used during homing	OK
SASTAT[0,1]	Get standalone program status 0 – Stopped 1 – Running 2 – Paused 4 – In Error	0-4
SA[LineNumber]	Get standalone line LineNumber: [0,1784]	
SA[LineNumber]=[Value]	Set standalone line LineNumber: [0,1784]	
SCV	Returns the s-curve control	0 or 1
SCV=[0 or 1]	Enable or disable s-curve. If disabled, trapezoidal acceleration/ deceleration will be used.	OK
SL	Returns StepNLoop enable status	0 – StepNLoop Off 1 – StepNLoop On
SL=[0 or 1]	Enable or disable StepNLoop Control	OK
SLA	Returns maximum number of StepNLoop control attempt	28-bit number
SLA=[value]	Sets maximum number of StepNLoop control attempt	OK
SLE	Returns StepNLoop correction range value.	28-bit number
SLE=[value]	Sets StepNLoop correction range value.	OK
SLR	Returns StepNLoop ratio value	[0.001 – 999.999]
SLR=[factor]	Sets StepNLoop ratio value. Must be in the range [0.001 – 999.999]	OK
SLS	Returns current status of StepNLoop control	See Table 6.8
SLT	Returns StepNLoop tolerance value	32-bit
SLT=[value]	Sets StepNLoop tolerance value.	OK
SLOAD	Returns RunOnBoot parameter	See Table 6.12
SLOAD=[0 or 1]	Set RunOnBoot parameter	See Table 6.12
SPC[0,1]	Get program counter for standalone program	[0-1784]
SR[0,1]=[Value]	Control standalone program: 0 – Stop standalone program 1 – Run standalone program 2 – Pause standalone program 3 – Continue standalone program	OK
SSPD[value]	On-the-fly speed change. In order to use this command,	OK

	S-curve control must be disabled. Use SCV command to enable and disable s-curve acceleration/ deceleration control. Note that an “=” sign is not used for this command.	
SSPDM	Return on-the-fly speed change mode	[0-9]
SSPDM=[value]	Set on-the-fly speed change mode	OK
STOP	Stops the motor using deceleration if in motion.	OK
STORE	Store settings to flash	OK
SYNC	Read sync output configuration 1 – trigger when encoder equals position 2 – trigger when encoder is LESS than position 3 – trigger when encoder is GREATER than position	[1-3]
SYNC=[value]	Set sync output configuration 1 – trigger when encoder equals position 2 – trigger when encoder is LESS than position 3 – trigger when encoder is GREATER than position	OK
SYNF	Turn off sync output	OK
SYNO	Turn on sync output	OK
SYNP	Get trigger position	28 bit signed number
SYNP=[value]	Set trigger position	28 bit signed number
SYNT	Get pulse width time (ms). Only applicable if sync output configuration is set to 1.	Milli-seconds
SYNT=[value]	Set pulse width time (ms). Only applicable if sync output configuration is set to 1. Max 30ms	OK
T[value]	On-the-fly target change	OK
TOC	Get time-out counter (ms)	32-bit number
TOC=[value]	Set time-out counter (ms)	OK
V[1-100]	Read variables 1-100	28-bit number
V[1-100]=[value]	Set variables 1-100	OK
VER	Get firmware version	VXXX
X[value]	Moves the motor to absolute position value using the HSPD, LSPD, and ACC values.	OK
Z+	Homes the motor in positive direction using the Z index encoder channel ONLY.	OK
Z-	Homes the motor in negative direction using the Z index encoder channel ONLY.	OK
ZH+	Homes the motor in positive direction using the home switch and then Z index encoder channel.	OK
ZH-	Homes the motor in negative direction using the home switch and then Z index encoder channel.	OK

Table 10.0

Error Codes

If an ASCII command cannot be processed by the ACE-SXE, the controller will reply with an error code. See below for possible error responses:

Error Code	Description
?[Command]	The ASCII command is not understood by the ACE-SXE
?ABS/INC is not in operation	T[] command is invalid because a target position move is not in operation
?Bad SSPD Command	SSPD move parameter is invalid
?DIO Enabled	Cannot control digital output because DIO mode is enabled
?Index out of Range	The index for the command sent to the controller is not valid.
?Moving	A move or position change command is sent while the ACE-SXE is outputting pulses.
?SA running	Cannot enable DIO mode because stand-alone is running
?SCV ON	Cannot perform SSPD move because s-curve is enabled
?Speed out of range	SSPD move parameter is out of the range of the SSPDM speed window.
?State Error	A move command is issued while the controller is in error state.
?Sub not Initialized	Call to a subroutine using the GS command is not valid because the specified subroutine has not been defined.

Table 10.1

11. Standalone Language Specification

;

Description:

Comment notation. In programming, comment must be in its own line.

Syntax:

; [Comment Text]

Examples:

```

;***This is a comment
JOGX+           ;***Jogs axis to positive direction
DELAY=1000      ;***Wait 1 second
ABORT           ;***Stop immediately all axes including X axis

```

ABORTX

Description:

Motion: Immediately stop motion without deceleration.

Syntax:

ABORTX

Examples:

```

JOGX+           ;***Jogs axis to positive direction
DELAY=1000      ;***Wait 1 second
ABORTX          ;***Stop axis immediately

```

ABS

Description:

Command: Changes all move commands to absolute mode.

Syntax:

ABS

Examples:

```

ABS             ;***Change to absolute mode
PX=0           ;***Change position to 0
X1000          ;***Move X axis to position 1000
WAITX
X3000          ;***Move X axis to position 3000
WAITX

```

ACC

Description:

Read: Get acceleration value

Write: Set acceleration value.

Value is in milliseconds.

Syntax:

Read: [variable] = ACC

Write: ACC = [value]

ACC = [variable]

Examples:

ACC=300 ;***Sets the acceleration to 300 milliseconds

V3=500 ;***Sets the variable 3 to 500

ACC=V3 ;***Sets the acceleration to variable 3 value of 500

AI[1-2]

Description:

Read: Gets the analog input value. ACE-SXE has 2 analog inputs.

Range is from 0-5000 mV

Syntax:

Read: [variable] = AI[1-2]

Conditional: IF AI[1-2]=[variable]

ENDIF

IF AI[1-2]=[value]

ENDIF

Examples:

IF AI1 < 500

DO=1 ;***If analog input 1 is less than 500, set DO=1

ENDIF

DEC

Description:

Read: Get deceleration value

Write: Set deceleration value.

Value is in milliseconds.

Syntax:

Read: [variable] = DEC

Write: DEC = [value]

DEC = [variable]

Examples:

DEC=300 ;***Sets the deceleration to 300 milliseconds

V3=500 ;***Sets the variable 3 to 500

DEC=V3 ;***Sets the deceleration to variable 3 value of 500

DELAY

Description:

Set a delay (1 ms units)

Syntax:

Delay=[Number] (1 ms units)

Examples:

```
JOGX+           ;***Jogs axis to positive direction
DELAY=10000     ;***Wait 10 second
ABORTX          ;***Stop axis
```

DI

Description:

Read: Gets the digital input value. ACE-SXC has 8 digital inputs.

Digital inputs are active high

Syntax:

```
Read: [variable] = DI
Conditional: IF DI=[variable]
                ENDIF

                IF DI=[value]
                ENDIF
```

Examples:

```
IF DI=0
    DO=1           ;***If all digital inputs are triggered, set DO=1
ENDIF
```

DI[1-6]

Description:

Read: Gets the digital input value. ACE-SXE has 6 digital inputs.

If digital input is on (i.e. input is pulled to GND of opto-supply), the bit status is 0. Otherwise, the bit status is 1.

Syntax:

```
Read: [variable] = DI[1-6]
Conditional: IF DI[1-6]=[variable]
                ENDIF

                IF DI[1-6]=[0 or 1]
                ENDIF
```

Examples:

```
IF DI1=0
    DO=1           ;***If digital input 1 is triggered, set DO=1
ENDIF
```

DO

Description:

Read: Gets the digital output value

Write: Sets the digital output value

ACE-SXE has 2 digital outputs.

If digital output is turned on (i.e. the output is pulled to GND), the bit status is 1. Otherwise, the bit status is 0.

Syntax:

Read: [variable] = DO

Write: DO = [value]

DO = [variable]

Conditional: IF DO=[variable]

ENDIF

IF DO=[value]

ENDIF

Examples:

DO=3 ;***Turn on both bits

DO[1-2]

Description:

Read: Gets the individual digital output value

Write: Sets the individual digital output value

ACE-SXE has 2 digital outputs.

If digital output is turned on (i.e. the output is pulled to GND), the bit status is 1. Otherwise, the bit status is 0.

Syntax:

Read: [variable] = DO[1-2]

Write: DO[1-2] = [0 or 1]

DO[1-2] = [variable]

Conditional: IF DO[1-2]=[variable]

ENDIF

IF DO[1-2]=[0 or 1]

ENDIF

Examples:

DO1=1 ;***Turn DO1 on

DO2=1 ;***Turn DO2 on

ECLEARX

Description:

Write: Clears motor error status. Also clears a StepNLoop error.

Syntax:

Write: ECLEARX

Examples:

```
ECLEARX                ;***Clears motor error
```

ECLEARSX

Description:

Write: Clears StepNLoop error status. ECLEAR also clears a StepNLoop error

Syntax:

Write: ECLEARSX

Examples:

```
ECLEARSX                ;***Clears StepNLoop error
```

ELSE

Description:

Perform ELSE condition check as a part of IF statement

Syntax:

ELSE

Examples:

```
IF V1=1
    X1000                ;***If V1 is 1, then move to 1000
    WAITX
ELSE
    X-1000               ;***If V1 is not 1, then move to -1000
    WAITX
ENDIF
```

ELSEIF

Description:

Perform ELSEIF condition check as a part of the IF statement

Syntax:

ELSEIF [Argument 1] [Comparison] [Argument 2]

[Argument] can be any of the following:

- Numerical value
- Pulse or Encoder Position
- Digital Output
- Digital Input
- Enable Output
- Motor Status

[Comparison] can be any of the following

= Equal to

> Greater than
 < Less than
 >= Greater than or equal to
 <= Less than or equal to
 != Not Equal to

Examples:

```

IF V1=1
  X1000
  WAITX
ELSEIF V1=2
  X2000
  WAITX
ELSEIF V1=3
  X3000
  WAITX
ELSE
  X0
  WAITX
ENDIF
  
```

END

Description:

Indicate end of program.
 Program status changes to idle when END is reached.

Note: Subroutine definitions should be written AFTER the END statement

Syntax:

```
END
```

Examples:

```

X0
WAITX
X1000
WAITX
END
  
```

ENDIF

Description:

Indicates end of IF operation

Syntax:

```
ENDIF
```

Examples:

```

IF V1=1
  X1000
  WAITX
ENDIF
  
```

ENDSUB

Description:

Indicates end of subroutine
When ENDSUB is reached, the program returns to the previously called subroutine.

Syntax:

ENDSUB

Examples:

```
GOSUB 1
END
```

```
SUB 1
    X0
    WAITX
    X1000
    WAITX
ENDSUB
```

ENDWHILE

Description:

Indicate end of WHILE loop

Syntax:

ENDWHILE

Examples:

```
WHILE V1=1          ;***While V1 is 1 continue to loop
    X0
    WAITX
    X1000
    WAITX
ENDWHILE          ;***End of while loop so go back to WHILE
```

EO

Description:

Read: Gets the enable output value

Write: Sets the enable output value

Syntax:

Read: [variable] = EO

Write: EO = [value]

EO = [variable]

Conditional: IF EO=[variable]
ENDIF

IF EO=[value]

ENDIF

Examples:

```
EO=1          ;***Energize motor
```

EX

Description:

Read: Gets the current encoder position

Write: Sets the current encoder position

Syntax:

Read: [variable] = E[axis]

Write: EX = [0 or 1]

EX = [variable]

Conditional: IF EX=[variable]
ENDIF

IF EX=[value]
ENDIF

Examples:

EX=0 ;***Sets the current encoder position to 0

GOSUB

Description:

Perform go to subroutine operation

Subroutine range is from 0 to 31.

Note: Subroutine definitions should be written AFTER the END statement

Syntax:

GOSUB [subroutine number]

[Subroutine Number] range is 0 to 31

Examples:

GOSUB 0
END

SUB 0
X0
WAITX
X1000
WAITX
ENDSUB

HLHOMEX[+ or -]

Description:

Command: Perform homing using current high speed, low speed, and acceleration.

Syntax:

HLHOMEX[+ or -]

Examples:

HLHOMEX+ ;***Homes the motor at low speed in the positive direction
WAITX

HOMEX[+ or -]

Description:

Command: Perform homing using current high speed, low speed, and acceleration.

Syntax:

HOMEX[+ or -]

Examples:

HOMEX+ ;***Homes axis in positive direction

HSPD

Description:

Read: Gets high speed. Value is in pulses/second

Write: Sets high speed. Value is in pulses/second.

Range is from 1 to 6,000,000.

Syntax:

Read: [variable] = HSPD

Write: HSPD = [value]

HSPD = [variable]

Examples:

HSPD=10000 ;***Sets the high speed to 10,000 pulses/sec

V1=2500 ;***Sets the variable 1 to 2,500

HSPD=V1 ;***Sets the high speed to variable 1 value of 2500

IF

Description:

Perform IF condition check

Syntax:

IF [Argument 1] [Comparison] [Argument 2]

[Argument] can be any of the following:

Numerical value

Pulse or Encoder Position

Digital Output

Digital Input

Enable Output

Motor Status

[Comparison] can be any of the following

= Equal to

> Greater than

< Less than

>= Greater than or equal to

<= Less than or equal to

!= Not Equal to

Examples:

IF V1=1

X1000

ENDIF

INC

Description:

Command: Changes all move commands to incremental mode.

Syntax:

INC

Examples:

```

INC           ;***Change to incremental mode
PX=0         ;***Change position to 0
X1000        ;***Move axis to position 1000 (0+1000)
WAITX
X2000        ;***Move axis to position 3000 (1000+2000)
WAITX
  
```

JOGX[+ or -]

Description:

Command: Perform jogging using current high speed, low speed, and acceleration.

Syntax:

JOGX[+ or -]

Examples:

```

JOGX+        ;***Jogs axis in positive direction
STOPX
WAITX
JOGX-        ;***Jogs axis in negative direction
STOPX
WAITX
  
```

JOYENA

Description:

Write: Enable/Disable joystick feature

Syntax:

Write: JOYENA=[value]

Examples:

```

JOYENA=1     ;***Enable joystick feature
JOYENA=0     ;***Disable joystick feature
  
```

JOYHSX

Description:

Write: Set high speed setting for joystick control

Syntax:

Write: JOYHSX= [value]
JOYHSX= [variable]

Examples:

```

JOYHSX=10000 ;***High speed of axis is set to 10,000 pps
  
```

JOYDELX

Description:

Write: Set maximum delta value of change in speed for joystick control

Syntax:

Write: JOYDELX= [value]
JOYDELX= [variable]

Examples:

JOYDELX=100 ;***Speed delta of axis is set to 100 pps

JOYNOX

Description:

Write: Set negative outer limit for joystick control

Syntax:

Write: JOYNOX= [value]
JOYNOX= [variable]

Examples:

JOYNOX=-10000 ;*** negative outer limit of axis set to -10000
JOYNIX=-9000 ;*** negative inner limit of axis set to -9000
JOYPIX=9000 ;*** positive inner limit of axis set to 9000
JOYPOX=10000 ;*** positive outer limit of axis set to 10000

JOYNIX

Description:

Write: Set negative inner limit for joystick control

Syntax:

Write: JOYNI = [value]
JOYNI= [variable]

Examples:

JOYNOX=-10000 ;*** negative outer limit of axis set to -10000
JOYNIX=-9000 ;*** negative inner limit of axis set to -9000
JOYPIX=9000 ;*** positive inner limit of axis set to 9000
JOYPOX=10000 ;*** positive outer limit of axis set to 10000

JOYPIX

Description:

Write: Set positive inner limit for joystick control

Syntax:

Write: JOYPIX= [value]
JOYPIX= [variable]

Examples:

JOYNOX=-10000 ;*** negative outer limit of axis set to -10000
JOYNIX=-9000 ;*** negative inner limit of axis set to -9000
JOYPIX=9000 ;*** positive inner limit of axis set to 9000
JOYPOX=10000 ;*** positive outer limit of axis set to 10000

JOYPOX

Description:

Write: Set positive outer limit for joystick control

Syntax:

Write: JOYPOX= [value]
JOYPOX= [variable]

Examples:

JOYNOX=-10000 ;*** negative outer limit of axis set to -10000
JOYNIX=-9000 ;*** negative inner limit of axis set to -9000
JOYPIX=9000 ;*** positive inner limit of axis set to 9000
JOYPOX=10000 ;*** positive outer limit of axis set to 10000

JOYTOLX

Description:

Write: Set zero tolerance value for joystick control

Syntax:

Write: JOYTOLX = [value]
JOYTOLX= [variable]

Examples:

JOYTOLX=10 ;*** zero tolerance value of axis set to 10

LHOMEX[+ or -]

Description:

Command: Perform homing using current high speed, low speed, and acceleration.

Syntax:

LHOMEX[+ or -]

Examples:

LHOMEX+ ;***Limit homes axis in positive direction
WAITX

LSPD

Description:

Read: Get low speed. Value is in pulses/second.

Write: Set low speed. Value is in pulses/second.

Range is from 1 to 400,000.

Syntax:

Read: [variable]=LSPD
Write: LSPD=[long value]
LSPD=[variable]

Examples:

LSPD=1000 ;***Sets the start low speed to 1,000 pulses/sec
V1=500 ;***Sets the variable 1 to 500
LSPD=V1 ;***Sets the start low speed to variable 1 value of 500

LTX

Description:

Write: Set latch enable

Range is [0,1]

Syntax:

Write: LTX=[0,1]

LTX=[variable]

Examples:

```

LTX=1                                ;***Enable latch
WHILE 1=1
    V2=LTSX                            ;***Get latch status
    IF LTSX = 2
        V3=LTEX                        ;***Get latch encoder value if latch is triggered
        V4=LTPX                        ;***Get latch position value if latch is triggered
    ENDIF
ENDWHILE

```

LTEX

Description:

Read: Get latch encoder value

Syntax:

Read: [variable]=LTEX

Examples:

See LTX

LTPX

Description:

Read: Get latch position value

Syntax:

Read: [variable]=LTPX

Examples:

See LTX

LTSX

Description:

Read: Get latch status

Syntax:

Read: [variable]=LTSX

Examples:

See LTX

MSTX

Description:

Read: Get motor status

Syntax:

```
Read: [variable]=MSTX
Conditional: IF MSTX=[variable]
                ENDIF

                IF MSTX=[value]
                ENDIF
```

Examples:

```
IF MSTX=0
    DO=3
ELSE
    DO=0
ENDIF
```

PX

Description:

Read: Gets the current pulse position

Write: Sets the current pulse position

Syntax:

```
Read: Variable = PX
Write: PX = [value]
        PX = [variable]
Conditional: IF PX=[variable]
                ENDIF
                IF PX=[value]
                ENDIF
```

Examples:

```
JOGX+           ;***Jogs axis to positive direction
DELAY=1000      ;***Wait 1 second
ABORTX          ;***Stop with deceleration all axes including X axis
PX=0            ;***Sets the current pulse position to 0
```

PS

Description:

Read: Get the current pulse speed

Syntax:

```
Read: Variable = PS
Conditional: IF PS=[variable]
                ENDIF
                IF PS=[value]
                ENDIF
```

Examples:

```
JOGX+           ;***Jogs axis to positive direction
DELAY=1000      ;***Wait 1 second
ABORTX          ;***Stop without deceleration
V1=PS           ;***Sets variable 1 to pulse speed
```

SCVX

Description:

Write: Set s-curve enable.
Range is from 0 or 1

Syntax:

Write: SCVX=[0 or 1]
SCVX=[variable]

Note: If s-curve is enabled for an axis, on-the-fly speed feature can not be used for the corresponding axis.

Examples:

```
SCVX=1          ;***Sets axis to use s-curve acceleration: on-the-fly speed
                 ; change is NOT allowed for this axis.
```

SLX

Description:

Write: Set StepNLoop closed-loop mode
Range is from 0 or 1

Syntax:

Write: SL=[0 or 1]

Examples:

```
SL=1 ;***Sets axis to closed-loop mode
```

SLSX

Description:

Read: Get StepNLoop status

Syntax:

Read: [variable]=SLSX
Conditional: IF SLSX =[variable]
ENDIF

IF SLSX =[value]
ENDIF

Examples:

```
IF SLSX != 0
    ECLEARX
ELSE
    ECLEARSX
ENDIF
```

SSPDX

Description:

Write: Set on-the-fly speed change for an individual axis.
Range is from 1 to 6,000,000 PPS

Syntax:

Write: SSPDX=[value]
SSPDX=[variable]

Note: If s-curve is enabled for an axis, on-the-fly speed feature can not be used for the corresponding axis.

Examples:

```
SCVX=0           ;***Disable s-curve acceleration
HSPD=1000        ;***X-axis high speed
LSPD=100         ;***Set low speed
ACC=100          ;***Set acceleration
JOGX+           ;***Jogs to positive direction
DELAY=1000      ;***Wait 1 second
SSPDX=3000      ;***Change speed on-the-fly to 3000 PPS
```

SSPDMX

Description:

Write: Set individual on-the-fly speed change mode
Range is from 0 to 9

Syntax:

Write: SSPDMX=[0-9]
SSPDMX=[variable]

Examples:

```
SCVX=0           ;***Disable s-curve acceleration
HSPD=1000        ;***X-axis high speed
LSPD=100         ;***Set low speed
ACC=100          ;***Set acceleration
JOGX+           ;***Jogs to positive direction
DELAY=1000      ;***Wait 1 second
SSPDMX=1         ;***Set on-the-fly speed change mode to 1
ACC=20000       ;***Set acceleration to 20 seconds
SSPDX=190000    ;***Change speed on-the-fly to 190000 PPS
```

STOPX

Description:

Command: Stop all axes if in motion with deceleration.
Previous acceleration value is used for deceleration.

Syntax:

STOPX

Examples:

```
JOGX+           ;***Jogs axis to positive direction
DELAY=1000      ;***Wait 1 second
STOPX           ;***Stop with deceleration
```

STORE

Description:

Command: Store all values to flash

Syntax:

STORE

Examples:

```
V80=EX           ;***Put encoder value in V80
DELAY=1000      ;***Wait 1 second
STORE           ;***Store V80 to non-volatile flash
```

SYNCFGX

Description:

Write: Set sync output configuration

Syntax:

Write: SYNCFGX=[value]
 SYNCFGX =[variable]

Examples:

```
SYNCFGX =1       ;*** Set sync output configuration to 1
SYNPOSX=3000     ;*** Set sync output position to 3000
SYNTIMEX=10     ;*** Set sync output pulse time to 10 ms
SYNONX          ;*** Turn on sync output feature

V1=1             ;*** Wait until sync output is triggered
WHILE V1 != 2
  V1=SYNSTATX
ENDWHILE

SYNOFFX         ;*** Disable sync output feature
```

SYNOFFX

Description:

Write: Disable sync output feature

Syntax:

Write: SYNOFFX

Examples:

See SYNCFGX

SYNONX

Description:

Write: Enable sync output feature

Syntax:

Write: SYNONX

Examples:

See SYNCFGX

SYNPOSX

Description:

Write: Set sync output position.

Syntax:

Write: SYNPOSX=[value]

Write: SYNPOSX=[variable]

Examples:

See SYNCFGX

SYNSTATX

Description:

Read: Get status for sync output

Syntax:

Read: [variable] = SYNS

Examples:

See SYNCFGX

SYNTIMEX

Description:

Write: Set pulse output width time for sync output

Syntax:

Write: SYN[axis]T=[value]

Examples:

See SYNCFGX

SUB

Description:

Indicates start of subroutine

Syntax:

SUB [subroutine number]

[Subroutine Number] range is 0 to 31

Examples:

GOSUB 1

END

SUB 1

 X0

 WAITX

 X1000

 WAITX

ENDSUB

V[1-100]

Description:

Assign to variable.

ACE-SXE has 100 variables [V1-V100]

Syntax:

V[Variable Number] = [Argument]

V[Variable Number] = [Argument1][Operation][Argument2]

Special case for BIT NOT:

V[Variable Number] = ~[Argument]

[Argument] can be any of the following:

- Numerical value
- Pulse or Encoder Position
- Digital Output
- Digital Input
- Enable Output
- Motor Status

[Operation] can be any of the following

- + Addition
- Subtraction
- * Multiplication
- / Division
- % Modulus
- >> Bit Shift Right
- << Bit Shift Left
- & Bit AND
- | Bit OR
- ~ Bit NOT

Examples:

```
V1=12345      ;***Set Variable 1 to 123
V2=V1+1      ;***Set Variable 2 to V1 plus 1
V3=DI        ;***Set Variable 3 to digital input value
V4=DO        ;***Sets Variable 4 to digital output value
V5=~EO       ;***Sets Variable 5 to bit NOT of enable output value
```

WAITX

Description:

Command: Tell program to wait until move on the certain axis is finished before executing next line.

Syntax:

WAITX

Examples:

```
X10000      ;***Move axis to position 10000
WAITX       ;***Wait until axis move is done
DO=3        ;***Set digital output
X3000       ;***Move axis to 3000
WAITX       ;***Wait until axis move is done
```

WHILE

Description:

Perform WHILE loop

Syntax:

WHILE [Argument 1] [Comparison] [Argument 2]

[Argument] can be any of the following:

- Numerical value
- Pulse or Encoder Position
- Digital Output
- Digital Input
- Enable Output
- Motor Status

[Comparison] can be any of the following

- = Equal to
- > Greater than
- < Less than
- >= Greater than or equal to
- <= Less than or equal to
- != Not Equal to

Examples:

```
WHILE V1=1      ;***While V1 is 1 continue to loop
  X0
  WAITX
  X1000
  WAITX
ENDWHILE
```

X

Description:

Command: Perform X axis move to target location

With other Axis moves in the same line, linear interpolation move is done.

Syntax:

X[value]
X[variable]

Examples:

```
ABS      ;***Absolute move mode
X10000   ;***Move to position 10000
WAITX
V10 = 1200 ;***Set variable 10 value to 1200
XV10     ;***Move axis to variable 10 value
WAITX
```

ZHOMEX[+ or -]

Description:

Command: Perform Z-homing using current high speed, low speed, and acceleration.

Syntax:

ZHOMEX[+ or -]

Examples:

ZHOMEX+ ;***Z Homes axis in positive direction
WAITX
ZHOMEX- ;***Z Homes axis in negative direction
WAITX

ZOMEX[+ or -]

Description:

Command: Perform Zoming (homing only using Z-index) using current high speed, low speed, and acceleration.

Syntax:

ZOMEX[+ or -]

Examples:

ZOMEX+ ;***Zomes axis in positive direction
WAITX
ZOMEX- ;***Zomes axis in negative direction
WAITX

12. Example Standalone Programs

Standalone Example Program 1 – Single Thread

Task: Set the high speed and low speed and move the motor to 1000 and back to 0.

```

HSPD=20000      ;* Set the high speed to 20000 pulses/sec
LSPD=1000       ;* Set the low speed to 1000 pulses/sec
ACC=300         ;* Set the acceleration to 300 msec
EO=1            ;* Enable the motor power
X1000           ;* Move to 1000
WAITX          ;* Wait for X-axis move to complete
X0              ;* Move to 1000
END             ;* End of the program

```

Standalone Example Program 2 – Single Thread

Task: Move the motor back and forth indefinitely between position 1000 and 0.

```

HSPD=20000      ;* Set the high speed to 20000 pulses/sec
LSPD=1000       ;* Set the low speed to 1000 pulses/sec
ACC=300         ;* Set the acceleration to 300 msec
EO=1            ;* Enable the motor power
WHILE 1=1       ;* Forever loop
    X1000        ;* Move to zero
    WAITX        ;* Wait for X-axis move to complete
    X0           ;* Move to 1000
ENDWHILE        ;* Go back to WHILE statement
END

```

Standalone Example Program 3 – Single Thread

Task: Move the motor back and forth 10 times between position 1000 and 0.

```

HSPD=20000      ;* Set the high speed to 20000 pulses/sec
LSPD=1000       ;* Set the low speed to 1000 pulses/sec
ACC=300         ;* Set the acceleration to 300 msec
EO=1            ;* Enable the motor power
V1=0            ;* Set variable 1 to value 0
WHILE V1<10     ;* Loop while variable 1 is less than 10
    X1000        ;* Move to zero
    WAITX        ;* Wait for X-axis move to complete
    X0           ;* Move to 1000
    V1=V1+1      ;* Increment variable 1
ENDWHILE        ;* Go back to WHILE statement
END

```

Standalone Example Program 4 – Single Thread

Task: Move the motor back and forth between position 1000 and 0 only if the digital input 1 is turned on.

```

HSPD=20000          ;* Set the high speed to 20000 pulses/sec
LSPD=1000           ;* Set the low speed to 1000 pulses/sec
ACC=300             ;* Set the acceleration to 300 msec
EO=1                ;* Enable the motor power
WHILE 1=1           ;* Forever loop
    IF DI1=1        ;* If digital input 1 is on, execute the statements
        X1000       ;* Move to zero
        WAITX       ;* Wait for X-axis move to complete
        X0          ;* Move to 1000
    ENDIF
ENDWHILE            ;* Go back to WHILE statement
END

```

Standalone Example Program 5 – Single Thread

Task: Using a subroutine, increment the motor by 1000 whenever the DI1 rising edge is detected.

```

HSPD=20000          ;* Set the high speed to 20000 pulses/sec
LSPD=1000           ;* Set the low speed to 1000 pulses/sec
ACC=300             ;* Set the acceleration to 300 msec
EO=1                ;* Enable the motor power
V1=0                ;* Set variable 1 to zero
WHILE 1=1           ;* Forever loop
    IF DI1=1        ;* If digital input 1 is on, execute the statements
        GOSUB 1     ;* Move to zero
    ENDIF
ENDWHILE            ;* Go back to WHILE statement
END

SUB 1
    XV1             ;* Move to V1 target position
    V1=V1+1000     ;* Increment V1 by 1000
    WHILE DI1=1    ;* Wait until the DI1 is turned off so that
    ENDWHILE       ;* 1000 increment is not continuously done
ENDSUB

```

Standalone Example Program 6 – Single Thread

Task: If digital input 1 is on, move to position 1000. If digital input 2 is on, move to position 2000. If digital input 3 is on, move to 3000. If digital input 5 is on, home the motor in negative direction. Use digital output 1 to indicate that the motor is moving or not moving.

```

HSPD=20000      ;* Set the high speed to 20000 pulses/sec
LSPD=1000       ;* Set the low speed to 1000 pulses/sec
ACC=300         ;* Set the acceleration to 300 msec
EO=1           ;* Enable the motor power
WHILE 1=1       ;* Forever loop
  IF DI1=1      ;* If digital input 1 is on
    X1000       ;* Move to 1000
  ELSEIF DI2=1 ;* If digital input 2 is on
    X2000       ;* Move to 2000
  ELSEIF DI3=1 ;* If digital input 3 is on
    X3000       ;* Move to 3000
  ELSEIF DI5=1 ;* If digital input 5 is on
    HOMEX-      ;* Home the motor in negative direction
  ENDIF
  V1=MSTX      ;* Store the motor status to variable 1
  V2=V1&7      ;* Get first 3 bits
  IF V2!=0
    DO1=1
  ELSE
    DO1=0
  ENDIF
ENDWHILE       ;* Go back to WHILE statement
END

```

Standalone Example Program 7 – Multi Thread

Task: Program 0 will continuously move the motor between positions 0 and 1000. Simultaneously, program 1 will control the status of program 0 using digital inputs.

```

PRG 0                                ;* Start of Program 0
HSPD=20000                          ;* Set high speed to 20000pps
LSPD=500                             ;* Set low speed to 500pps
ACC=500                              ;* Set acceleration to 500ms
WHILE 1=1                            ;* Forever loop
    X0                                ;* Move to position 0
    WAITX                            ;* Wait for the move to complete
    X1000                            ;* Move to position 1000
    WAITX                            ;* Wait for the move to complete
ENDWHILE                             ;* Go back to WHILE statement
END                                  ;* End Program 0

PRG 1                                ;* Start of Program 1
WHILE 1=1                            ;* Forever loop
    IF DI1=1                         ;* If digital input 1 is triggered
        ABORTX                       ;* Stop movement
        SR0=0                        ;* Stop Program 1
    ELSE                             ;* If digital input 1 is not triggered
        SR0=1                        ;* Run Program 1
    ENDIF                            ;* End if statements
ENDWHILE                             ;* Go back to WHILE statement
END                                  ;* End Program 1

```

Standalone Example Program 8 – Multi Thread

Task: Program 0 will continuously move the motor between positions 0 and 1000. Simultaneously, program 1 will monitor the communication time-out parameter and triggers digital output 1 if a time-out occurs. Program 1 will also stop all motion, disable program 0 and then re-enable it after a delay of 3 seconds when the error occurs.

```

PRG 0                                ;* Start of Program 0
HSPD=1000                            ;* Set high speed to 1000 pps
LSPD=500                              ;* Set low speed to 500pps
ACC=500                               ;* Set acceleration to 500ms
TOC=5000                              ;* Set time-out counter alarm to 5 seconds
EO=1                                   ;* Enable motor
WHILE 1=1                             ;* Forever loop
    X0                                 ;* Move to position 0
    WAITX                             ;* Wait for the move to complete
    X1000                             ;* Move to position 1000
    WAITX                             ;* Wait for the move to complete
ENDWHILE                              ;* Go back to WHILE statement
END                                    ;* End Program 0

PRG 1                                ;* Start of Program 1
WHILE 1=1                             ;* Forever loop
    V1=MSTX&1024                     ;* Get bit time-out counter alarm variable
    IF V1 = 1024                     ;* If time-out counter alarm is on
        SR0=0                        ;* Stop program 0
        ABORTX                       ;* Abort the motor
        DO=0                          ;* Set DO=0
        DELAY=3000;                  ;* Delay 3 seconds
        SR0=1                        ;* Turn program 0 back on
        DO=1                          ;* Set DO=1
    ENDIF
ENDWHILE                              ;* Go back to WHILE statement
END                                    ;* End Program 1

```

Appendix A: Speed Settings

HSPD value [PPS] †	Speed Window [SSPDM]	Min. LSPD value	Min. ACC [ms]	δ	Max ACC setting [ms]
1 - 16 K	0,1	10	2	500	$((\text{HSPD} - \text{LSPD}) / \delta) \times 1000$
16K - 30 K	2	10	1	1 K	
30K - 80 K	3	15	1	2 K	
80K - 160 K	4	25	1	4 K	
160K - 300 K	5	50	1	8 K	
300K - 800 K	6	100	1	18 K	
800K - 1.6 M	7	200	1	39 K	
1.6 M - 3.0 M	8	400	1	68 K	
3.0 M - 6.0 M	9	500	1	135 K	

Table A.0

†If StepNLoop is enabled, the [HSPD range] values needs to be transposed from PPS (pulse/sec) to EPS (encoder counts/sec) using the following formula:

$$\text{EPS} = \text{PPS} / \text{Step-N-Loop Ratio}$$

Acceleration/Deceleration Range

The allowable acceleration/deceleration values depend on the **LSPD** and **HSPD** settings.

The minimum acceleration/deceleration setting for a given high speed and low speed is shown in Table A.0.

The maximum acceleration/deceleration setting for a given high speed and low speed can be calculated using the formula:

Note: The ACC parameter will be automatically adjusted if the value exceeds the allowable range.

$$\text{Max ACC} = ((\text{HSPD} - \text{LSPD}) / \delta) \times 1000 \text{ [ms]}$$

Figure A.0

Examples:

- a) If **HSPD** = 20,000 pps, **LSPD** = 100 pps:
 - a. Min acceleration allowable: **1 ms**
 - b. Max acceleration allowable:
 $((20,000 - 100) / 1,000) \times 1,000 \text{ ms} = \mathbf{19900 \text{ ms}}$ (19.9 sec)

- b) If **HSPD** = 900,000 pps, **LSPD** = 1000 pps:
 - a. Min acceleration allowable: **1 ms**

- b. Max acceleration allowable:
 $((900,000 - 1000) / 39,000) \times 1000 \text{ ms} = \mathbf{23050 \text{ ms}}$ (23.05 sec)

Acceleration/Deceleration Range – Positional Move

When dealing with positional moves, the controller automatically calculates the appropriate acceleration and deceleration based on the following rules.

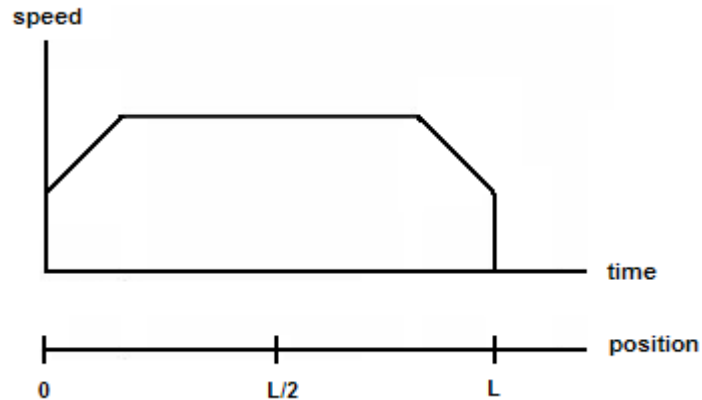

Figure A.1

- 1) ACC vs. DEC 1: If the theoretical position where the controller begins deceleration is less than $L/2$, the acceleration value is used for both ramp up and ramp down. This is regardless of the EDEC setting.
- 2) ACC vs. DEC 2: If the theoretical position where the controller begins constant speed is greater than $L/2$, the acceleration value is used for both ramp up and ramp down. This is regardless of the EDEC setting.
- 3) Triangle Profile: If either (1) or (2) occur, the velocity profile becomes triangle. Maximum speed is reached at $L/2$.

Contact Information

Arcus Technology, Inc.

3159 Independence Drive
Livermore, CA 94551
925-373-8800

www.arcustechnology.com

The information in this document is believed to be accurate at the time of publication but is subject to change without notice.