THINGET

Inverter V5/F5 Series

User Manual

Xinje Electronic Co., Ltd.
2008.01

THINGET

	Table of Contents	
	Preface	1
	<hr/>	
V5 Series	Safty Precautions	3
	<hr/>	
Inverter	Product Introductions	11
	<hr/>	
User Manual	Installation and Wiring	22
	<hr/>	
	Operation Descriptions	42
	<hr/>	
	Function Parameters	59
	<hr/>	
	Fault Diagnosis and Disposal	181
	<hr/>	
	Maintenance	189
	<hr/>	
	Communication Protocol	193
	<hr/>	

This manual includes the basic caution items that you should obey to ensure your personal safety, as well as to protect the product and the connected equipments. These items are highlighted in the manual by a warning triangle. Please comply with the essential electric operation rules that are not indicated in this manual.

Installing Precautions



Please comply with these items, incorrect operation may cause the system error working even abnormal. More serious would cause possession loss.

Correct Applications



The device and its components can only be used in the applications described in the catalog and the technical manuals, can only be connected with devices or components from other manufacturers which have been approved or recommended by Xinje.

The products will run normally in the condition of been transported, stored, configured and installed correctly, been operated and maintained as recommended.

Xinje Electronic Co., Ltd. Copyright reserved

Without written authority, please do not copy, transfer or use this document and its content. Anyone who disobeys this should take responsibility for the loss.

Obligation Declare

We have checked and confirmed that the contents in this manual were compatible with the hardware and software described. Since mistakes are hard to avoid, we cannot promise total accordant. This manual is subject to change without notices.

Table of Contents

Preface.....	1
Safety Precautions.....	3
1 Product Instruction.....	11
1-1. Product Overview.....	11
1-2. Product Technical Specification.....	13
1-3. Product Appearance:.....	18
1-4. Product Dimension.....	19
1-5. Choose The Accessories.....	20
2 Installation and Wiring.....	22
2-1. Installation Environment.....	22
2-1-1. Environment Requirement.....	22
2-1-2. Mounting Direction and Space.....	22
2-1-3. Mounting and Removing of The Frontal Panel.....	23
2-2. Precautions When Wiring.....	24
2-3. Wiring With The Main Circuit's Terminals.....	26
2-3-1. Wiring Diagram.....	26
2-3-2. Terminal Description.....	26
2-4. Basic Running Wiring.....	28
2-5. Configuration and Wiring of Control Circuit.....	29
2-5-1. Relative Position Between Terminals and jumpers and function Descriptions.....	29
2-5-2. Description of Terminals On The Control Board.....	30
2-5-3. Wiring of Analog input/output terminals.....	34
2-5-4. Connection of The Communication Terminals.....	36
2-6. Installation Guidance According To EMC Requirement.....	38

2-6-1. Suppressing The Noise.....	38
2-6-2. Local Wiring And Grounding.....	40
3 Operating Instructions.....	42
3-1. Running of The Inverter.....	42
3-1-1. Control mode of running command.....	42
3-1-2. Frequence setting mode.....	43
3-1-3. Running state.....	43
3-1-4. Running modes.....	43
3-2. Panel and its operation methods.....	46
3-2-1. Panel description.....	46
3-2-2. Function description of panel keys.....	47
3-2-3. Fuction description of LED and indicator.....	48
3-2-4. Display of the operation panel.....	49
3-2-5. Panel operation procedure.....	52
3-3. Start-up.....	57
3-3-1. Checking before starting up.....	57
3-3-2. Start up the inverter for the first time.....	57
4 Function Parameters.....	59
4-1. Function parameter table.....	59
4-2. Parameter description.....	105
4-2-1. Basic operating function parameters (Group P0)	105
4-2-2. Parameters of reference frequency (Group P1)	117
4-2-3. Starting and braking parameters (Group P2)	120
4-2-4. Auxiliary running parameters (Group P3)	124
4-2-5. Function parameters of terminal (Group P4)	135
4-2-6. Protective function parameters (Group P5)	153
4-2-7. Fault recording parameters (Group P6)	158
4-2-8. Close-loop control parameters (Group P7).....	159

4-2-9. Simple PLC operation parameters. (Group P8)	167
4-2-10. Traverse and measure function parameters (Group P9)	172
4-2-11. Vector control parameters (Group PA)	176
4-2-12. Special application function parameters (Group PB)	179
4-2-13. Factory setting (Group PF)	180
5 Fault Diagnosis and Countermeasures.....	182
5-1. Fault diagnosis and countermeasures.....	182
5-2. Fault records.....	187
5-3. Fault reset.....	187
6 Maintenance.....	189
6-1. Maintenance.....	189
6-1-1. Routine maintenance.....	189
6-2. Periodical care and maintenance.....	190
6-2-1. Periodical care.....	190
6-2-2. Periodical maintenance.....	191
6-3. Warranty of the inverter.....	191
7 Communication Protocol.....	193
7-1. Overview of communication protocol.....	193
7-2. Instruction of communication protocol.....	194
7-2-1. Communicating mode.....	194
7-2-2. Communication modes.....	195
7-2-3. Mode of communication port.....	195
7-3. Modbus-RTU communication protocol.....	196
7-3-1. Structure.....	196
7-3-2. Communication information.....	196
7-3-3. Communication parameter.....	199

Preface

—Essential introduction for this manual

Thank you for purchasing V5/F5 series inverter manufactured by Xinje Electronic Co., Ltd, this manual should be read and understood before attempting relevant operations.

1. Purpose of this manual

This manual offers guidance and introductions about how to use and maintains the inverter correctly, including functions, usages, installation, maintenance, etc.

2. Qualified personnel

This manual is intent for the following personnel:

- Inverter installation personnel
- Project technical personnel(electric engineer, electrician)
- Design personnel

The above personnel should read and understand this manual carefully before operating and debugging.

3. Validity of this manual

This manual may only be used for inverters made by Xinje.

4. Electronic Documents

In addition to our written manuals, we offer electronic documentations of our products by the following ways.

➤ User CD

There are software, user manual and application tip of relevant products.

➤ Website

Please visit Thinget Electronic Co.,Ltd. at www.thinget.com to obtain all variable electronic documents.

Safety Precautions

— Essential introduction about product operation

Upon unpacking, please confirm that: Check whether the model and the rated values on the nameplate of the inverter are in accordance with your order. Check if there is any damage occurred during transportation; please contact us or the distributor if you find any missing or damage of the products.

In order to use this product correctly, the user who uses the product for the first time must read this manual carefully and pay close attention to the safety precautions.

Please keep this manual properly, hand it to the terminal user and lay it on the place where the operators can read it easily.

◎ Safety Precautions ◎

Confirmations Upon Delivery



Notice

1. Never install an inverter that is damaged or missing components. Doing so can result in injury.

● Installation



Notice

1. Always hold the bottom of the inverter when carrying it. If the inverter is held by the front cover, the main body of the inverter may

fall, possible resulting in injury.

2. Attach the inverter to metal or other noncombustible materials. Fire can result if the inverter is attached to a combustible material.
3. Install a cooling fan or other cooling device when installing more than one inverter in the same enclosure so that the temperature of the air entering the inverters is below 45°C. Overheating can result in fires or other accidents.

● **Wiring**



Danger

1. Always turn off the input power supply before wiring. Otherwise, an electric shock or fire may occur.
3. Wiring must be operated by an authorized person qualified in electrical work. Otherwise, an electric shock or fire may occur.
5. Make sure to ground the ground terminals. Otherwise, an electric shock or fire may occur.
7. Always check the operation of any emergency stop circuits after they are wired. Otherwise, possibly result in injury (user responsibility for the wiring).
9. Never touch the output terminal directly by your hands or let the output terminals to come into contact with the inverter case. Never short the output terminals. Otherwise, an electric short or ground short may occur.
6. Never touch the internal circuit or the zero-component until power off and the charge indicator is off as there may still be high voltage i

inside the AC motor driver.



Notice

1. Confirm that the voltage of the main AC power supply satisfies the rated voltage of the Inverter. Injury and fire may occur if the voltage is not right.
2. Do not perform voltage withstand tests on the Inverter. Otherwise, semiconductor elements and other devices can be damaged.
4. Connect braking resistors, Braking Resistor Units, and Braking Units as shown in the I/O wiring examples. Otherwise, a fire may occur.
4. Tighten all terminal screws to the specified tightening torque. Otherwise, a fire may occur.
5. Do not connect AC power to output terminals U, V, and W.
The interior parts of the Inverter will be damaged if voltage is applied to the output terminals.
6. Do not connect phase-advancing capacitors or LC/RC noise filters to the output circuits. The Inverter may be damaged or internal parts burnt if these devices are connected.
7. Do not connect electromagnetism switch, electromagnetism contactor to output circuit. When the inverter is running with load, the electromagnetism switch and electromagnetism contactor will generate inrush current which will cause inverter's over current protection.
8. Do not disassemble the whole front cover as disassembling the top front while wiring is ok. Otherwise, inverter internal parts may be damaged.

● Maintenance and Inspection



Danger

1. Do not touch the inverter terminals, as they may carry high voltage. Otherwise, an electric short may occur.
2. Make sure to have protective cover .Always have the protective cover in place when power is being supplied to the Inverter. When attaching the cover, please with the power turns off. Otherwise, an electric short may occur.
3. Maintenance, inspection, must be performed only by authorized personnel. Otherwise, an electric short may occur.



Notice

1. A CMOS IC is used in the control board. Handle the control board and CMOS IC carefully. The CMOS IC can be destroyed by static electricity if touched directly.
2. Do not change the wiring, or remove connectors or the Digital Operator, during operation. Otherwise, The devices may be damaged.

◎ Usage Precautions ◎**➤ Constant torque low speed running**

When the inverter outputs to a common motor at low speed for a long term, the output rated torque should be derated due to the worsening radiating effect. If low speed constant torque long term running is required, then a special variable frequency motor is needed.

➤ Motor insulation

When using the V5/F5 series inverter, make sure to confirm the insulation of the motor which will be used to avoid device damage. Besides, do the periodic check for the insulation condition of the motor located in the bad environment to guarantee the system can operate safely.

➤ Negative torque over load

If in the case of improving over load, negative torque may occur. Braking units should be connected with the inverter, or over current and over voltage fault may happen.

➤ Mechanical resonance point of load

The inverter may encounter the mechanical resonance point of load within certain output frequency range. Jump frequencies have to set to avoid it.

➤ Capacitor and resistor

Because the inverter output pulse wave, capacitor and resistors shouldn't be connected with the output terminals of the inverter, or the inverter may trip or components may be damaged; Besides, don't connect switch components such as air switch and contactor with the output terminals is

recommended, as shown in Fig.0-1(If switch components need to be connected with the output terminals, make sure output current of the inverter is zero when switch is acting).

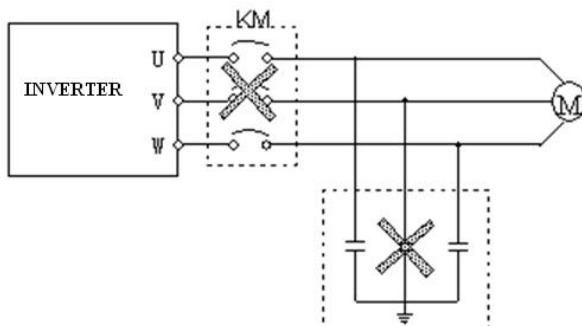

Fig.0-1 Capacitor is prohibited to be connected with output terminals of inverter

➤ **Deration according to basic frequency setting**

When the basic frequency is lower than the reference frequency, please consider duration for the motor so as to avoid motor's damage caused by overheating.

➤ **Running at frequency above 50Hz**

If running at frequency above 50Hz, besides the increment of vibration and noise, the ranges of running speed of motor shaft and mechanical device have to be guaranteed. Be sure to make an enquiry first.

➤ **The electro-thermal protective value of motor**

If the applicable motor is selected as per requirements, the inverter can perform the thermal protection to the motor. If the ratings of applied motor are not in compliance with the inverter, be sure to adjust the protective value or adopt other protective measures to guarantee the safe

running of motor.

➤ **Altitude and deration**

When the altitude is higher than 1000m, the cooling effect of inverter is deteriorated because of the rareness of air, deration must be considered, shown in Fig.0-2 which indicates the relationship between the altitude and rated current of frequency inverter.

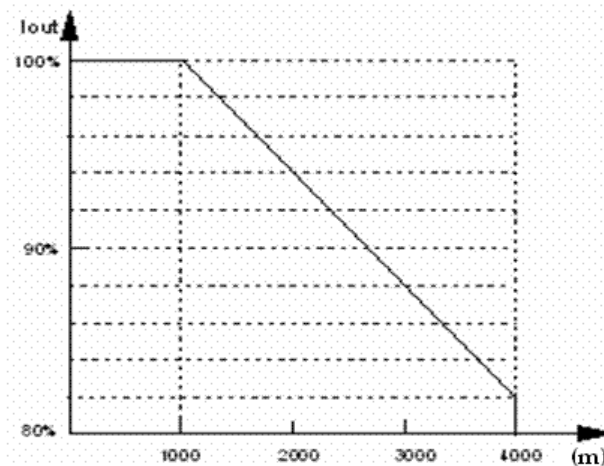

Fig. 0-2 The relationship between the altitude and rated current of frequency inverter

➤ **About protection classes**

The protection class of V5/F5 series inverter IP20 is reached in the case of status display unit or keyboard.

© Note Regarding Disposal ©

When you dispose inverter, please pay attention that:

Explosion risk of capacitor: The capacitors in the main circuits may explode when they are burned.

Waste gas when plastic parts are burned: Poisonous gas may be generated when front panel is burned.

Dispose method: Please dispose as industrial rubbish.

1 Product Instruction

1-1. Product overview

V5/F5 series inverter is produced by Thinget Co., Ltd with high performance, easy operating and low noise. It is a innovative product with a series advanced and practical running and control functions such as practical PI, flexible input and output terminals, parameter modification online, fixed length control, traverse operation, RS485 control, bus-mastering. It provides OEM customers with high integrated, reliable, cost-effective solution.

Name Designation Rules

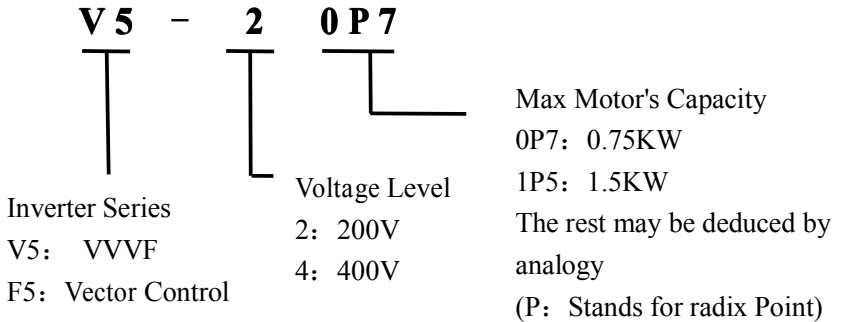

V5 Series of Inverter

Input Voltage	Model	Rated Capacity (KVA)	Rated Output Current (A)	Motor's Power (KW)
220V Single-phase	V5-20P7	1.5	4.7	0.75
	V5-21P5	2.8	7.5	1.5
380V Three-phase	V5-41P5	2.5	4.0	1.5
	V5-42P2	3.0	6.0	2.2
	V5-43P7	5.9	9.6	3.7
	V5-45P5	8.5	14.0	5.5
	V5-47P5	11	17.0	7.5

1-2. Product technical specification

1. Technical specification

200V

Type V5-2 _ _ _		0P7	1P5
Output	Match Motor(KW)	0.75	1.5
	Output Current(A)	4.7	7.5
	Voltage(V)	AC 200	
	Frequency Range(Hz)	0~500	
	Frequency Resolution(Hz)	0.01	
	Over-loading Ability	150%Rated Current for 1 minutes , 180% Rated Current for 1 second	
Input	Rated Voltage/Frequency	Single-phase 220V,50/60Hz	
	AC voltage permit fluctuate range	Voltage: -20% ~ +20% Voltage Unbalance Rate: <3%	
	Frequency fluctuate Range	Frequency: $\pm 5\%$	
	Power Capacity (KVA)	1.5	2.8

400V

V5/F5 series inverter

Model V5-4_ _ _		1P5	2P2	3P7	5P5	7P5
Output	Motor(KW)	1.5	2.2	3.7	5.5	7.5
	Output Current(A)	4.0	6.0	9.6	14.0	17.0
	Voltage(V)	AC 380				
	Frequency Range (Hz)	0 ~ 500				
	Frequency accuracy (Hz)	0.01				
	Over load Ability	150% Rated Current for 1 minute, 180% Rated Current for 1 Second				
Input	Rated Current /Frequency	Three-phase 380V; 50Hz/60Hz				
	AC voltage fluctuate range	Voltage: -20% ~ +20% Voltage Unbalance Rate: <3%				
	Frequency fluctuate range	Frequency: ±5%				
	Power Capacity(KVA)	2.5	3.0	5.9	8.5	11

Common characteristics

Environment	Application environment	In-door, free from direct sunlight, dust, corrosive gas, oil mist, steam, water drop etc.
	Elevation	Lower than 1000m (The inverter should be derated when the elevation is higher than 1000m)
	Ambient Temperature	-10°C ~ +40°C
	Humidity	Less than 90%RH, No dry bulb

	Vibration	Less than 5.9 m/s^2 (0.6M)
	Storage Temperature	$-20^{\circ}\text{C} \sim +60^{\circ}\text{C}$
Structure	Protect Configuration	IP20(In the state of "state display units" or "keyboard")
	Cooling Manner	Fan cooling
Installation		Surface mounted or install inside cabinet

2. General Specification

Main Control Function	V5/F5 series inverter	Modulation models	Optimized space voltage vector SVPWM modulation
	Control models	Control models	Space voltage vector SVPWM control (Optimized compensation characteristic in low frequency dead zone)
	Frequency definition	Frequency definition	Digital Setting: $\times\pm 0.01\%$ highest frequency; Analog Setup: $\times\pm 0.2\%$ highest frequency
	Frequency accuracy	Frequency accuracy	Digital Setting: 0.01Hz; Analog Setup: $\times 0.1\%$ highest frequency
	Start frequency	Start frequency	0.40Hz~20.00Hz
	Torque boost	Torque boost	Auto torque boost, manual torque boost 0.1%~30.0%
	V/F curve	V/F curve	Five modes: constant torque V/F curve, 1 V/F curve mode by user and 3 kinds of torque-derating modes (2.0 order, 1.7 order, 1.2 order)
	Acc/Dec curve	Acc/Dec curve	Two modes: linear Acc/Dec, S ramp Acc/Dec; seven kinds of Acc/Dec time (Maximum:6000 minutes) and unit(minute or second) is selectable.
	DC injection braking	DC injection braking	Initial frequency of DC injection braking process: 0~15.00Hz Braking time: 0~60.0 s Braking current: 0~80%
	Dynamic braking	Dynamic braking	Internal dynamic braking, can be connected with external braking resistor
	Jog	Jog	Range of jog frequency: 0.1Hz ~ 50.00Hz, Acc/Dec time of jog operation 0.1~60.0s
	Internal PI	Internal PI	Be able to form close loop control system easily
	Multi-step speed running	Multi-step speed running	Multi-step speed running can be realized by internal PLC or control terminals
	16	Auto voltage regulation	Auto voltage regulation

1-3. Product appearance:

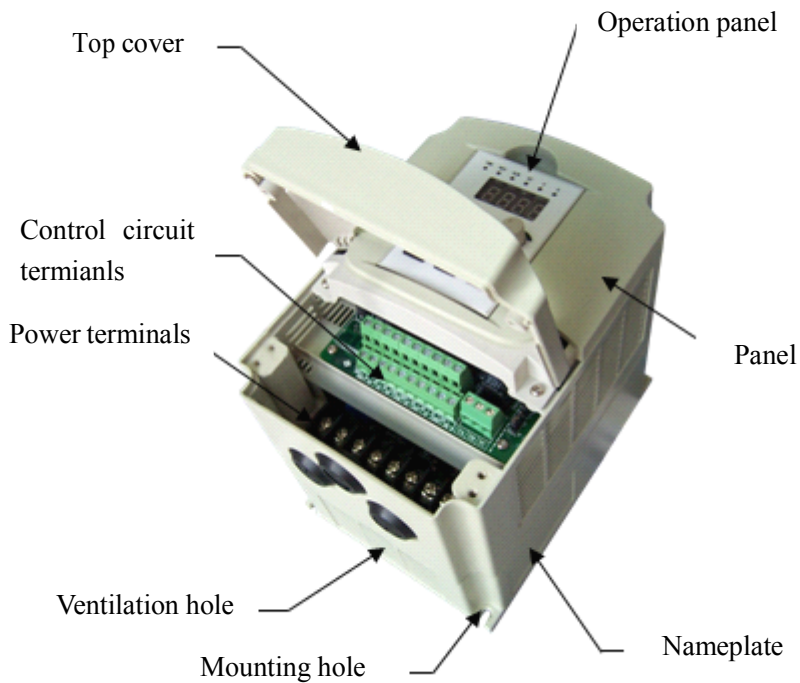

1-4. Product dimension

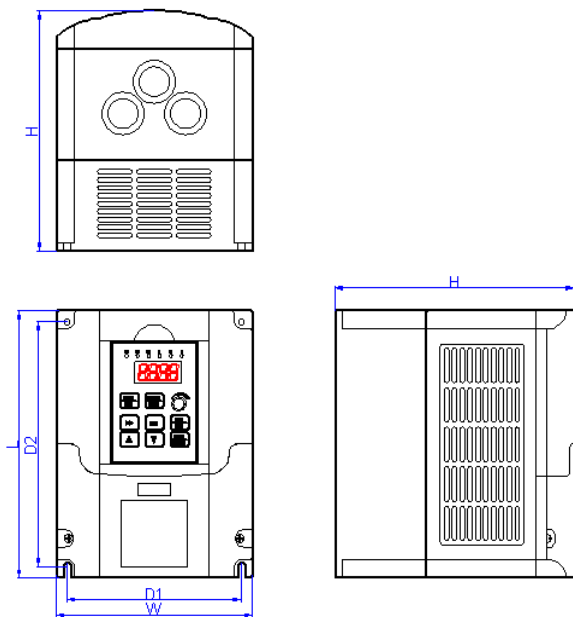

Dimension of Installation Holes (Unit: mm)

Specification	W	D1	L	D2	H
V5-20P7	138	114	215	204	152
V5-21P5					
V5-41P5					
V5-42P2	182	140	325	319	152
V5-43P7					
V5-45P5					
V5-47P5					

1-5. Choose fittings

➤ Brake Resistor

V5 series inverter include brake unit. If you have any energy expenditure brake requirement, please choose suitable brake resistance according to figure 1-1.

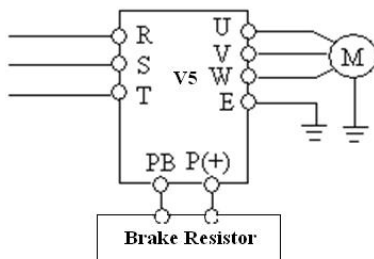

Figure 1-1 Wiring of inverter and brake units

Table 1-1 Brake resistor selection

Model	Motor Power (KW)	Resistor Value (Ω)	Resistor power (W)
V5-20P7	0.75	150	200
V5-21P5	1.5	100	400
V5-41P5	1.5	300	400
V5-42P2	2.2	200	500
V5-43P7	3.7	200	500
V5-45P5	5.5	100	500
V5-47P5	7.5	75	1000

2 Installation and Wiring

2-1. Installation environment

2-1-1. Environment requirement

- Ambient temperature: It is required to be within the range of $-10^{\circ}\text{C}\sim 40^{\circ}\text{C}$. The inverter should be derated when the temperature over 40°C , at the same time ventilation and heat dissipation should be enhanced.
- Far away from the location with direct sunlight, dust, floating fiber or metal powder.
- Mount in the location free of corrosive gas and combustible gas.
- Mount in the location free of condensing, dry bulb and the humidity should less then 95%RH.
- Mount in the location where vibration less than $5.9\text{m/s}^2(0.6\text{G})$
- Far away from electromagnetism interfere source and other electric instruments sensitive with electromagnetism interfere.

2-1-2. Mounting location

- Mount the inverter vertically under general condition.
- The requirement of space and distance are shown in Fig. 2-1.
- When several inverters are mounted up and down, air flow diverting plate should be fixed in between as shown in Fig. 2-2.

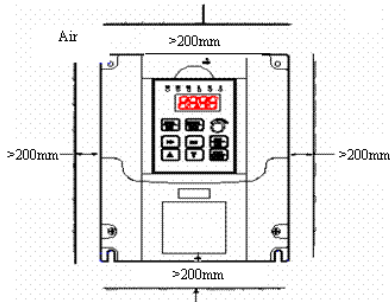
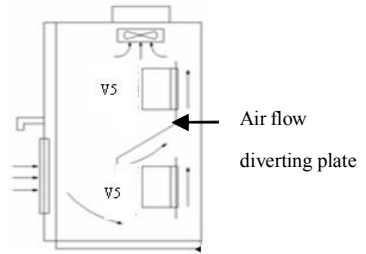
**Fig. 2-1 Mounting Space****Fig.2-2 Mounting of Multiple Inverters**

2-1-3. Mounting and removing

- Removing: Remove the four screws on the cover with phillips screwdriver
- Mounting: Align the mounting holes and then fix the screws.

2-2. Wiring



Caution

- Wiring after power off for at least 10 minutes, otherwise, an electronic short may occur.
- Do not connect AC power to output terminals U, V and W.
- Both the inverter and the motor should be grounded to guarantee safety as there may be leakage current with the inverter. The cross section of earthing copper cable must be above 3.5mm².
- Dielectric strength test of the inverter has been done in factory, so you need not do it again.
- Do not install electromagnetic contactor, absorption capacitor or other absorption resistance-capacitance devices, as shown in Fig3-3.
- The inverter should be connected with the power supply via breaker to provide over-current protection and convenience for disconnecting the AC supply to maintain the inveter.
- The wiring of relay input and output circuit (X1~X6, FWD, REV, OC, DO) should select the twisted-pair or shield cable with cross section over 0.75 mm². One terminal of the shield layer should be hung in air and the other terminal should be connected with the inverter's grounding terminal E with lenth less than 50m.



Danger

- The cover can be removed only when the power is switched off, all the LEDs on the panel are off and waiting at least for 10 minutes.
- Wiring work can be performed until the voltage between internal electrolysis capacity “+” and “-“ below DC36V.
- Wiring work can only be done by trained and professional personnel.
- Before usage, check whether the main voltage is suitable for the requirement of inverter input voltage. Otherwise, injury and device damage may be occur.

2-3. Wiring of main circuit terminals

2-3-1. Wiring diagram

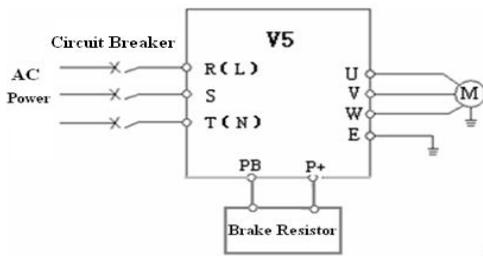

Fig. 2-3 Wiring of main circuit

2-3-2. Terminal description

Main circuit input/output terminals are shown in Table2-1.

Table 2-1 Main circuit input/output terminals description

Applied Type	Main Loop terminals	Voltage Class	Terminal Name	Function Description
V5-20P7 V5-21P5	 L N P+ PB E U V W	Single-phase 220V	L,N	Single-phase AC 220V input terminals
			U,V,W	Three-phase AC output terminals
			P+,PB	Wiring terminals for brake resistor
			E	Earth terminals
V5-41P5 26	 R S T P+ PB E U V W	Three-	R,S,T	Three-phase AC 380V in

V5-42P2 V5-43P7 V5-45P5 V5-47P5	(V5-41P5 without terminal E)	phase 380V		put terminals
			U,V,W	Three-phase AC output terminals
			P+, PB	Wiring terminals for brake resistor
			E	Earth terminals

2-4. Basic run wiring

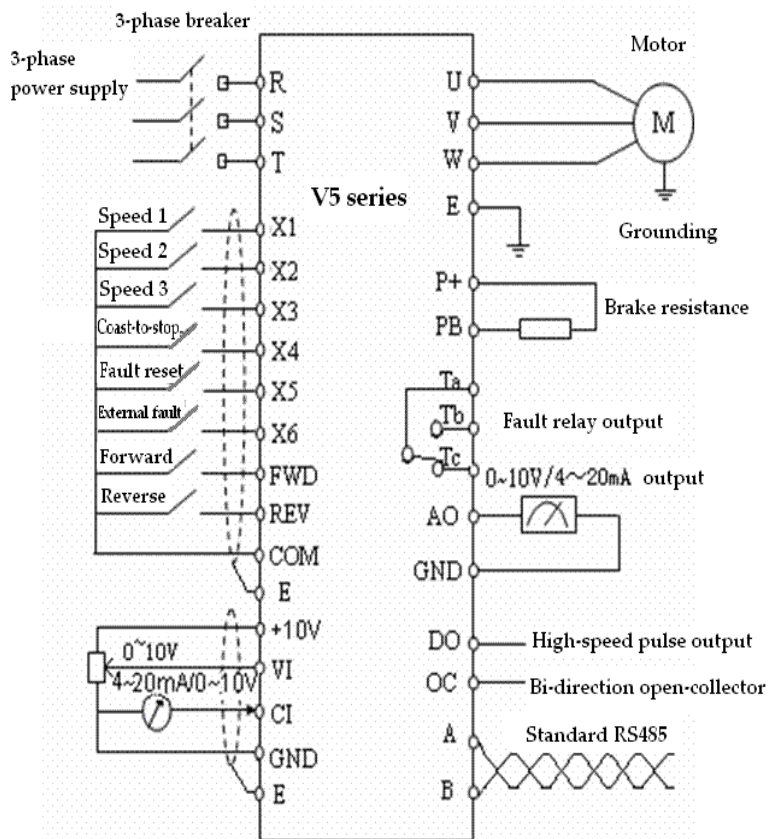

Note: V5-41P5 without E terminals (earth terminals)

2-5. Setting and wiring of control loop

2-5-1. Relative position and function descriptions of terminals and jumpers in control board

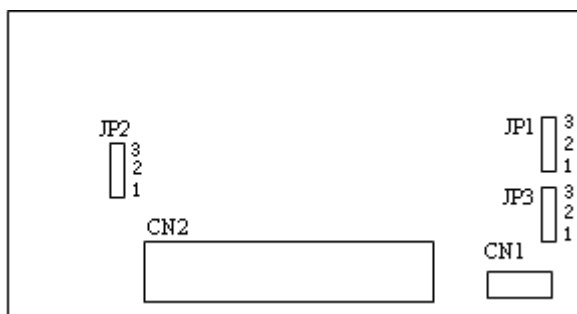

Fig. 2—4 position of terminals and jumpers in control board

The relative position of terminals and jumpers in control board are shown in Fig. 2-4, the function descriptions of terminals are shown in Table 2-3 and the function descriptions of jumper and their setup method are shown in Table 2-2. Before usage, all the terminals should be wiring correctly and all the jumpers in the control board should be set up in right mode. Cross section over 1mm² is recommended as the terminals' wiring.

Table 2-2 Function of jumpers

Jumper	Function	Setup	Default
JP1	Pulse output terminal DO power selection	1—2 connect: External power supply 2—3 connect: Inverter's internal 24V power supply	External power supply

JP2	Analog output terminal AO output	1—2 connect : 4~20mA , AO terminal output current signal 2—3 connect: 0~10V, AO terminal output voltage signal	0~10V
JP3	CI current/voltage input modes selection	1—2 connect : V side: 0~10V voltage signal 2—3 connect : I side: 4~20mA current signal	4~20mA

2-5-2. Description of terminals in control board

1. Functions of terminal are shown below in Table 2-3:

Table 2-3 Function of CN1 in control board

Type	Terminal	Name	Function Description	Specification
Relay output terminal	TA	Inverter Multifunctional relay output terminals	Inverter Multifunctional relay output terminals. Please refer to terminal function parameters P4.11 and description of output terminals	TA-TC: normally close, TA-TB: normally open Contact Capacity: AC250V/2A (COSΦ=1) AC250V/1A (COSΦ=0.4) DC30V/1A
	TB			
	TC			

2. CN2 Terminals which control loop:

**Fig. 2—5 Terminals in control board**

3. CN2 terminals' function description is show below:

Table 2-4 CN2 terminals' function description

Type	Terminal	Name	Terminal Function Description	Specification
	A	RS485 port	Plus terminal of RS485 differential signal	standard RS485 port, please use twisted cable or shielded cable
	B		Minus terminal of RS485 differential signal	
Multifunction output terminal	OC	Open collector output terminal 1	Multi-function digital value output terminal, Refer to output terminals' function description of terminal function parameters P4.10 for details. (common terminals: COM)	optical coupling isolation output voltage range:9~30V highest output current:50mA usage please refer to P4.10
Pulse output terminal	DO	Open collector pulse output terminal	Multi-function digital value output terminal, Refer to output terminals' function description of terminal function parameters P4.20, P4.21 for details	Output frequency range: Decided by function code P4.21, highest 20KHz

V5/F5 series inverter

			(common terminals: COM)	
Analog input	VI	Analog input VI	analog voltage input (reference ground: GND)	Input voltage range : 0~10V (input resistance: 47K Ω) accuracy: 1/1000
	CI	Analog input CI	Analog current/voltage input, voltage and current are selected by jumper JP3 and the default is current. (reference ground: GND)	Input voltage range : 0~10V (input resistance: 47K Ω) Input current range : 4~20mA (input resistance: 500 Ω) accuracy: 1/1000
Analog output	AO	Analog output AO	Analog voltage/current output, They are selected by jumper JP2 and the default is voltage which can indicate 7 values. (reference ground: GND)	Voltage output range: 0~10V Current output range: 4~mA
Running control terminal	FWD	Forward running command	Forward/reverse digital value command. Refer to P4.08 for details	Optical coupling isolation input Input resistance: R=2K Ω Highest input frequency:200Hz
	REV	Reverse running command	(instruction about 2-wire and 3-wire control function).	
Multifunction input terminal	X1	Multifunction input 1	Multi-function digital value input terminals, refer to input terminals'	Input voltage range: 9~30V
	X2	Multifunction		

		on input 2	function description in terminals' function parameters P4. (common terminal: COM)	
	X3	Multifunction on input 3		
	X4	Multifunction on input 4		
	X5	Multifunction on input 5		
	X6	Multifunction on input 6		
Power supply	24V	+24V power supply	Offer +24V power supply (negative terminal: COM)	-
	10V	+10V power supply	Offer +10V power supply (negative terminal: GND)	Highest output current:50mA
	GND	+10V power supply common terminal	Reference of analog signal and +10V power supply	COM in isolated with GND
	COM	+24V power supply common terminal	Digital signals input, output common terminal	

2-5-3. Analog input/output terminal wiring

1. VI terminal analog voltage signal input, wiring as shown below:

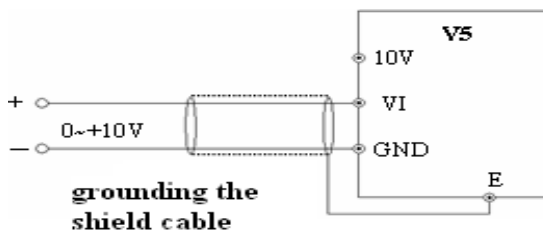

Fig. 2-6 VI terminal wiring diagram

2. CI terminals analog signal input, jumper select input voltage (0~10V) and input current (4~20mA), wiring are as shown below:

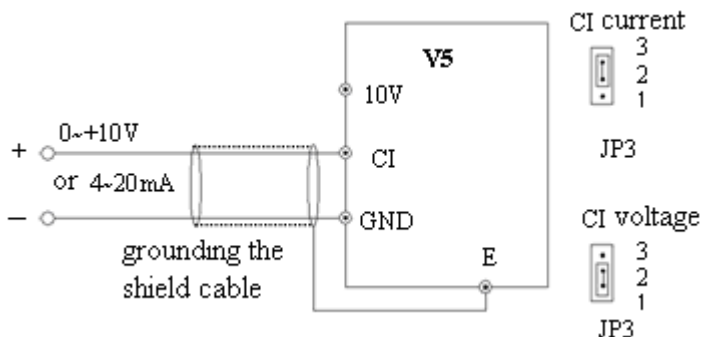
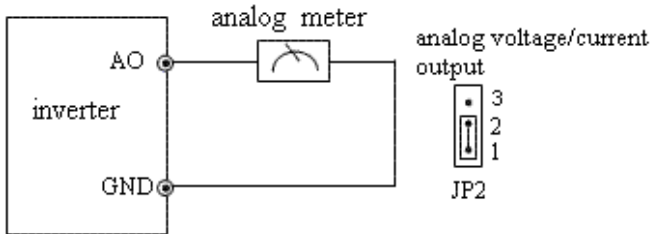

Fig. 2-7 CI terminals' wiring**3. Analog output terminal AO's wiring**

Analog output terminal AO can indicate various physical quantities with external analog meter, output voltage 0~10V, output current 4~20mA, wiring is shown in Fig.2-8.

**Fig. 2-8 Analog input/output wiring****Note:**

- (1) When use analog input, you can install filter capacitance or inductor common between VI and GND, or CI and GND.
- (2) Because analog input signal is easily interference by external disturbance, the shield cable must be used, the cable length must be short and the shield layer must be grounded well.

2-5-4. Connection of communication terminals

The communication port of this inverter is standard RS485 port.

With the following wiring method, you can buildup control system of one host with one slave or one host with several slaves. Also, you can realize the functions such as real time monitor, remote control, high level automation and others for the inveter with the host (PC or PLC) software.

- Connection of inverter's RS485 port and the host:

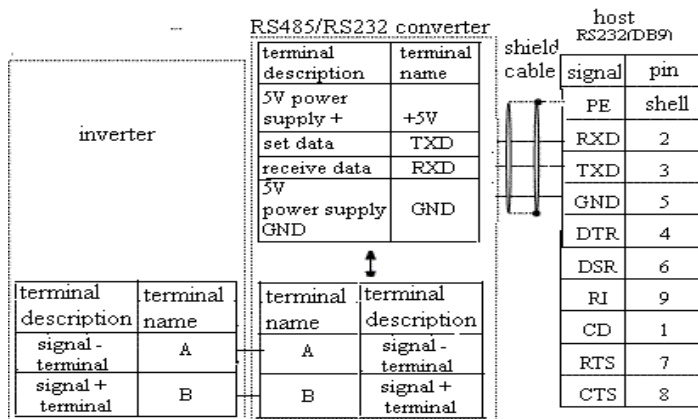

Fig. 2-9 RS485-(RS485/232)-RS232 cable connection

- More than one inverter can be connected through RS485 with the PLC(or PC) as the host, as shown in Fig.2-10; Also, you can select one inverter as host and the other inverters as slaves, as shown in 2-11. Because with the inverter's number increasing, the communication system will be interfered easier, the following wiring is recommended.

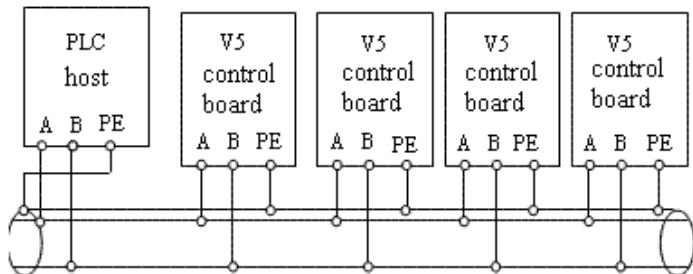

Fig. 2-10 Connection of PLC and inverters

(Inverters and motors are all well grounded)

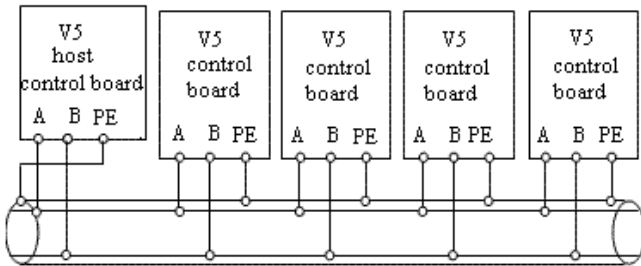

Fig. 2-11 Connection of several inverters

(Inverters and motors are all well grounded)

If the communication is still failed with the above connection, you can adopt the following measures:

- (1) Power supply PLC (or PC) separately or isolate its power supply.
- (2) Use with the communication wire and reduce the inverter's carrier frequency.

2-6. Installation guidance according to EMC requirement

As the inverter's output wave is PWM, electromagnetic noise will be inevitably generated while it working. To reduce the inverter's disturbance for the external devices, this chapter introduces the installation method with the following aspects: suppressing the noise, local wiring, grounding, leak current, usage of power supply filter.

2-6-1. Suppressing the noise

1. Noise type

The noise made by inverter may be effect the neaby instruments and devices and the effection is related to inveter's control system, noise interference rejection of the devices, wiring environment, safty distance, grounding method and other factors. The noise contains the following types: electrostatic induction, circuit transmit, space transmit, electro magnetic induction and so on.

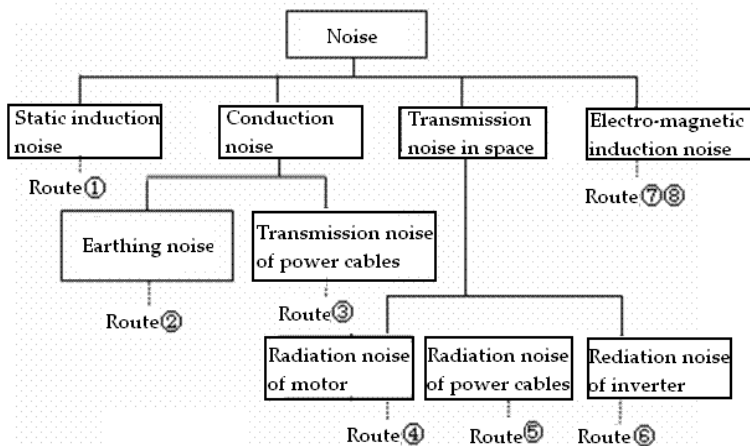

2. Essential countermeasure for suppressing noise

Table 2-5 Countermeasures for suppressing noise

Noise transmit path	Countermeasure
②	When the external equipment forms a loop with the inverter, the equipment may operated incorrectly due to the inverter's earth leakage current. The problem can be solved if the equipment is not grounded.
③	If the external equipment shares the same AC supply with the inverter, the inverter's noise may be transmitted along its input power supply cables, which may cause interference to other external equipments. Take the following actions to solve this problem: Install noise filter at the input side of the inverter, and use an isolation transformer or line filter to prevent the noise from disturbing the external equipment.
④⑤⑥	<p>(1)The equipment and the signal cables should be as far away as possible from the inverter. The signal cables should be shielded and the shielding layer should be grounded. The signal cables should be located as far away as possible from the input/output cables of the inverter. If the signal cables must cross over the power cables, they should be placed at right angle to one another.</p> <p>(2) Install high-frequency noise filter (ferrite common-mode choke) at the input and output of the inverter to suppress the emission noise of power lines.</p> <p>(3) Motor cables should be placed in a tube thicker than 2mm or buried in a cement conduit. Power cables should be placed inside a metal tube and be</p>

	grounded by shielding layer (Motor cable should be a 4-core cable, where one core should be connected to the grounding of the inverter and another should be connected to the motor's enclosure).
①⑦⑧	Don't route the signal cables in parallel with the power cables or bundle these cables together. Other equipment should also be located as far away as possible from the inverter. The signal cables should be placed as far away as possible from the input/output cables of the inverter. The signal cables and power cables should be shielded cables. Devices with electric field and magnetic field should be placed keep certain distance and at right angle to the inverter.

2-6-2. Local wiring and grounding

- (1) Parallel arrangement should be avoided between cable from inverter to motor (from U, V, W) and power supply cable (R, S, T or L, N terminal input wire). The distance should be more than 30cm.
- (2) Inverter's output cables from U, V, W terminals is recommend to through metal tube or metal slot.
- (3) Control signal cables should be shield and the shield layer should be connected with inverter's E terminal with well grounding.
- (4) Grounding cables connected with inverter's E terminal should be grounded directly. It can't be shared with other devices.
- (5) Don't route the signal cables in parallel with the power cables (R, S, T or L, N with U, V, W) or bundle these cables together, at least 20~60 cm distance should be kept (related with power current), If the signal cables and power cables needed to be intersected, they should

vertical to each other, as shown in Fig2-12

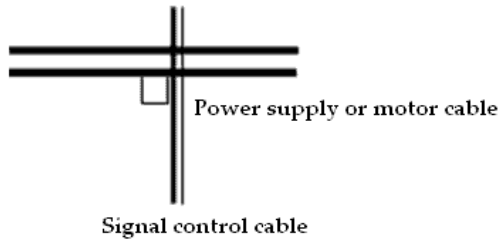

Fig. 2-12 Wiring requirement of system

- (6) Feeble current cables of Signal control and sensor should be grounded respectively.
- (7) Connect other devices with inverter's power input terminals (R,S,T or L,N) is Prohibited.

3 Operating Instructions

3-1. Running of the inverter

3-1-1. Control mode of running command

The inverter control START, STOP, JOG and other running actions via three command modes.

1. Operation panel

Control by ,  and  keys on the operation panel (default setting)

2. Control terminals

Control by terminals FWD, REV, COM to form 2-wire modes, or control by one terminal from X1~X6, FWD and REV to form 3-wire modes.

3. Serial port

The operations such as START, STOP can be controlled by the upstream host or other devices which can communicate with the inverter.

The control mode can be selected by parameter 0.03 and multi-function input terminal (No. 23, 24 can be selected by P4.00~ P4.07).

Warning : The user must ensure that the control mode selected is suitable for the application. Wrong selection may cause damage to equipment or human injury.

3-1-2. Frequency setting mode

In common operating mode, the inverter has 8 possible routes to input reference frequency, the reference frequency can be input by:

- 0: keypad analog potentiometer
- 1: ▲ and ▼ keys on the panel
- 2: Operation panel function code digital
- 3: Terminals UP/DOWN
- 4: Serial port
- 5: Analog VI
- 6: Analog CI
- 7: Pulse terminal (PULSE)
- 8: Combination

3-1-3. Running state

There are two running state: stopping state, running state.

Stopping state: After the inverter is switched on and initialized, If no operating command is executed, then the inverter enters stopping state.

Running state: The inverter enters running state after it receive the running command

3-1-4. Running modes

V5 inverter has 5 kinds of running modes which can be sequenced

according to the priority: Jog running→Close loop running→PLC running→Multi-step speed running→Simple running, as shown in Fig. 3-1.

0: Jog running

When the inverter is in the stopping state, it will  running according to jog frequency (refer to P3.06~P3.08 for details) after receiving jog running command (e.g after pressing key)

1: Close loop

If the close loop running function is enabled (P7.00=1), the inverter will select the close loop running modes, that is, it will perform PI regulation according to the reference and feedback value(refer to parameters in group P7), PI regulation output is the essential command of inverter's output frequency. Close loop running can be disabled by multi-function terminal (No.27 function) and the inverter will select a running mode with low priority.

2: PLC running

If PLC function is enabled (Unit's place of P8.00 is set to a non-zero value), the inverter will enter PLC running mode and running in the pre-defined running mode (refer to parameter description in group P8). PLC running can be disabled by multi-function terminal (No.29 function) and the inverter will select a running mode with low priority.

3: Multi-speed running

Select Multi-frequency 1~7 (P3.26 ~ P3.32) to realize multi-speed running by no-zero combination of multi-function terminal (No.1, 2 and 3 functions)

4: Common running

Common running is actually the open loop running mode.

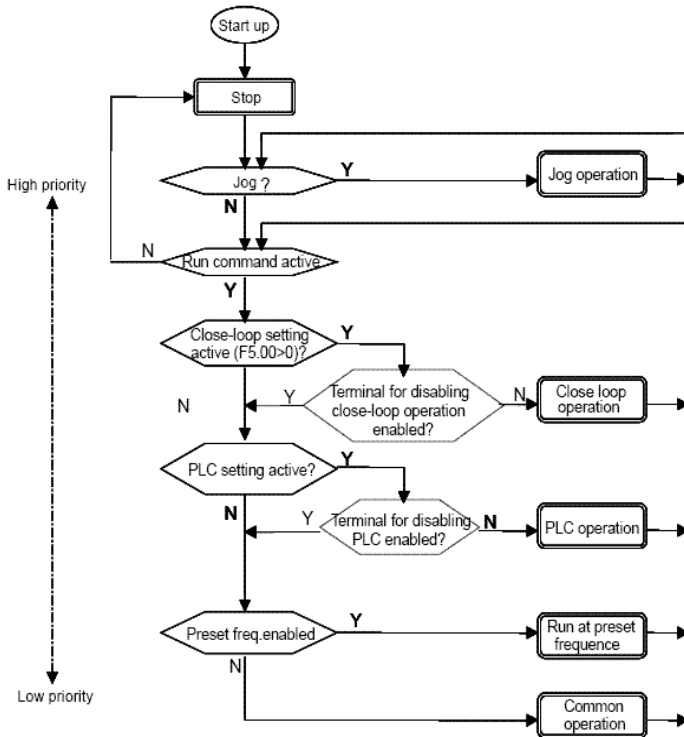

Fig. 3-1 Running state of V5/F5

Except “Jog running”, other 4 kinds running modes can be enabled by multi-frequency setting method. Besides, “PLC running”, “multi-speed running”, “common running” can be used as traverse frequency.

3-2. Panel and its operation methods

3-2-1. Panel description

Start, speed, stop, brake, running parameter setting and control of the peripheral can be performed by inverter's operation panel and control terminals, operation panel is shown in Fig.3-2.

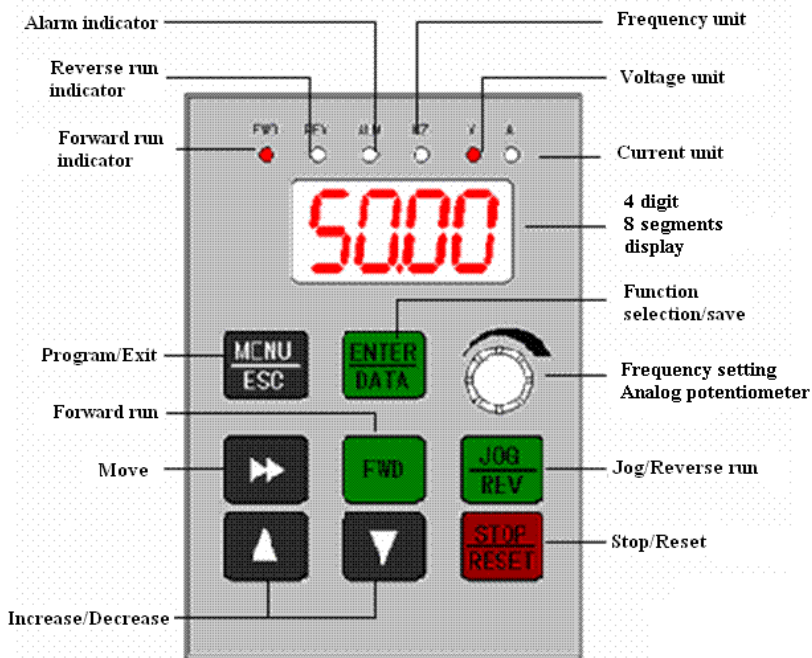











Fig. 3-2 Illustration of operation panel

3-2-2. Function description of panel keys

There are 8 keys and 1 analog potentiometer in operation panel and the function of each is shown in the following table.

Key	Name	Function
	Forward run	In panel control mode, press this key to start to forward run
	Stop/Reset	This key is for stopping the running of the inverter with keyboard control mode in inverter's running state, and for resetting in fault state.
	Program/Exit	Enter or exit programming state
	Jog/Reverse run	P3.45=0, start to jog P3.45=1, start to reverse run
	Increase	Increase data or code
	Decrease	Decrease data or code
	Shift	In editing state, press this key to select the bit to be changed; in other state, this key is used to scroll through the parameters.
	Function selection /data	In program state, press this key to enter the next menu or saving the parameters.

	Analog potentiometer	When P0.01=0, select this key and adjust analog potentiometer to control the inverter's output frequency.
---	----------------------	---

3-2-3. Function description of LED and indicator

The operation panel consists of a 4-digit 8 segments LED display, 3 unit indicators and 3 state indicators. The three unit indicators have 6 different combinations and each combination corresponds to one type of unit while setting parameters. The relationship between the combination of the indicators and the unit is shown in Fig.3-3.

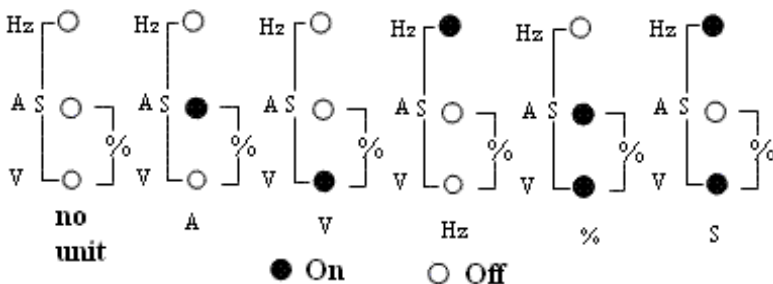

Fig. 3—3 Unit repressed by combination of the indicators

3 status indicators are above LED display in the panel and from left to right are: forward indicator FWD, reverse indicator REV, alarm indicator ALM. The functions of these indicators are shown in Table3-1

Table 3-1 Functions of status indicators

Item	Function
------	----------

Display functions	LED display		Display inverter's current status parameters and setting parameters
	Status indicators	FWD	Positive phase , Forward indicator, show inverter output positive phase.After connecting with motor, the motor will run forward
		REV	Reverse indicator , show inverter output negative phase.The motor will run in reverse after connected
	ALM	This indicator will on when the inverter occur fault alarm.	

3-2-4. Display of the operation panel

The inverter's operation panel can display four parameters in stopping, editing, fault alarming and running.

1. Parameters displayed in stopping status

When the inverter stops operation, operation panel displays monitor parameters in stopping status, the normally content is setting frequency (b-01 monitor parameter). As shown in Fig.3-4,the unit indicator on the top right indicates the unit of this parameter.

Pressing  key can display other monitor parameters in stopping status circularly (the first seven monitor parameters in B group are fault displayed value and the other monitor parameters can be defined by function code P3.41 and P3.42, please refer to Chapter 5 for details). Press



in display status can shift to b-01 which can set frequency, otherwise the panel will display the last monitor parameter constantly.

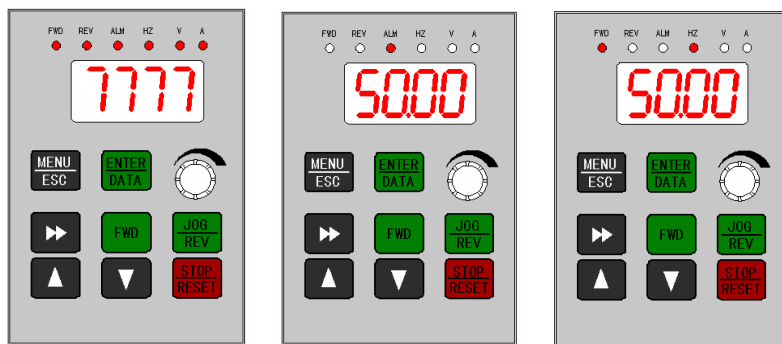

A
Initialize at power on,
display dynamic image



B
Stopping state, display
stopping information

C
Running state, display
running information

Fig. 3—4 Display during initialize, STOP and RUN

2. Parameters displayed in running status



When the inverter receive the running command, it starts to enter running status and operation panel will display running monitor parameters, the default parameter is output frequency (b-00 monitor parameter), as shown in Fig.3-4-B, the unit indicator on the top right indicates the unit of this parameter



Press  key can display parameter in running status circularly (defined by function code P3.41 and P3.42). While displaying, press  key to shift to the default parameter b-00, that is output frequency, Otherwise, the operation panel will display the last monitor parameter constantly.

3. Alarm information

When then inverter detects a fault signal, the panel will display fault



code, the code will flash to catch your attention as shown in Fig.3-5; Press  key to view the relative fault parameters in stopping status, and then press  to shift to fault code display.

If you want to view fault information, press  to view P6 parameter in editing status. After you find out and solve the default, the inverter can be reset by  in operation panel or control terminals or communication command. The fault code will not disappear until the fault is cleared.



Note: For some serious default such as over current, over voltage etc. please do not reset the inverter to rerun before confirming that the default is cleared, otherwise the inverter may be damaged.



Fig.3—5 Alarming display status

4. Editing status

This status can be entered by pressing  key in stopping, running or fault alarming status (if there is a user's password, you should input correct password, refer to P0.00 and Fig 3-9 for details). This status can

be displayed in three level menu, they are: code group → code No. → code parameter, you can enter the sub-menu by pressing . In code parameter status, press  to save parameter and press  to exit without saving.

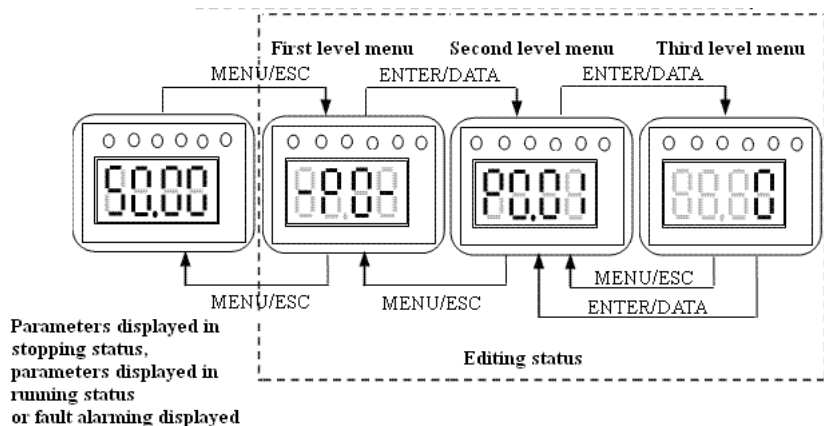



Fig. 3—6 Editing status

3-2-5. Panel operation procedure

The following shows how to do various operation by operation panel.

1. Parameter Display

Press  key to display monitor parameters in b group. First display the parameter No, then shift to display parameter value automatically in one second. The shift method is shown below in Fig 4-

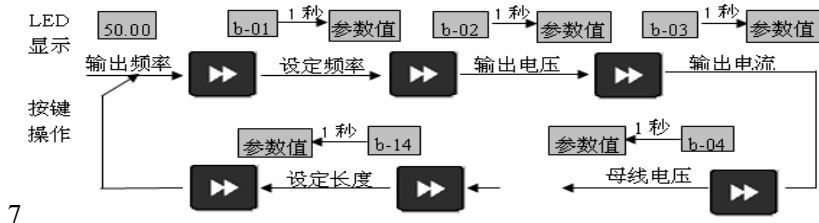

Fig. 3-7 Setting the parameters in running status

1) State parameter can only display seven parameters from b-00 to b-06 with factory setting, you can view other status parameters by changing P3.41 and P3.42.

(2) When you want to view status monitor parameter, press **ENTER DATA** can shift to default monitor parameter display status. The default monitor parameter in stopping states is setting frequency and in running states is output frequency.

2. Function parameter

Take the following as an example: reset function parameter P3.065 from 5.00Hz to 8.50Hz.

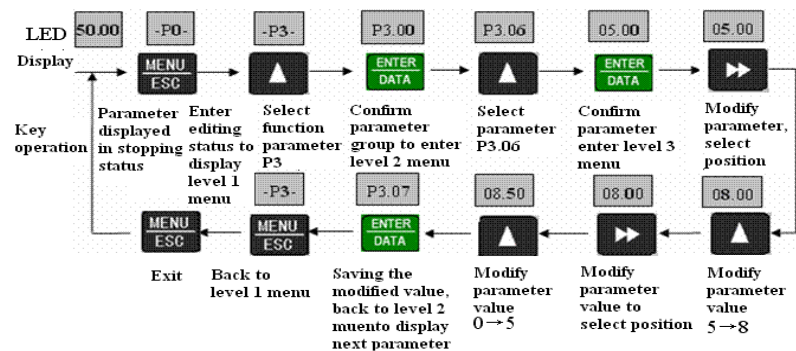

Fig. 3-8 Parameter editing

In three level menu states, the parameter can't be changed if none digit of the parameter is flashing, the possible reasons are:

- (1) The setting of this parameter can not be changed, such as the actual detected parameters or recorded parameters.
- (2) This parameters can only be changed in stopping state and can not be changed in running state.
- (3) Parameters have been protected. If P 3.01 is set to 1 or 2, the setting of all the parameters can not be changed by wrong operation. If you really want to change the setting, first set P3.01 to 0.

3. Jog

When the inverter in stop state, press JOG key and holde it, the panel will display start output frequency and the frequency will ramp to 5Hz, then releasing the JOG key, the frequency will drop to 0Hz and the inverter will stop.

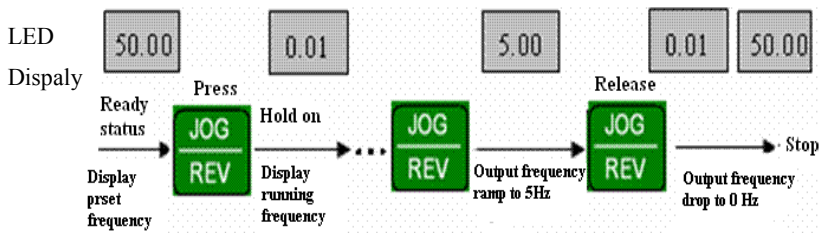



Key Operation

Fig. 3-9 Jog Operation

4. Setting user's password

Setting P0.00 as "2345" and let it as user's password. The bold digit indicates flashing digit.

Note:



(1) You can press  key to inquire P6 function parameter group in the status of parameters displayed in fault, the range of the parameters is P6.01 ~ P6.06, when you press  key, parameter No. will firstly displayed and the parameter value will be displayed automatically in one second.



(2) While inquiring, You can press  key to back to fault parameter displayed status.

6. Setting frequency via and

Suppose that the parameters at stop is displaying, P0.01=1, the operation mode is shown below:

(1) Frequency adjustment adopt integral mode;

(2) When pressing  , the digital increases from unit's place of LED, then it carries from unit's place to ten's place, the digital of ten's place starts to increase, as the same, when it carries from ten's place to hundred's place, the digital of hundred's place starts to increase, so does the digital of thousand's place. If you release  and press it again, the digital will restart to increase from the unit's place of LED.

(3) When pressing  , the digital decreases from unit's place of LED, then it borrow from ten's place , the digital of ten's place starts to decrease. So does the digital in hundred's place and thousand's place. If you release  key and press it again, it will restart to decrease from the unit's place of LED.

7. Lock the panel

If the panel is unlocked, press  key for five seconds can lock the

panel.

8. Unlock the panel

If the panel is locked, press  key for five seconds can unlock the panel.

3-3. Start-up

3-3-1. Checking before starting up

Please wire the inverter according to “Wiring” in this manual.

3-3-2. Start up the inverter for the first time

After checking the wiring and AC power, switch on the AC power supply to electrify the inverter. The inverter's panel will display dynamic screen and then the contactor closes. When the LED displays preset frequency, the initialization of this inverter is completed. The procedure is shown as Fig. 3-12:

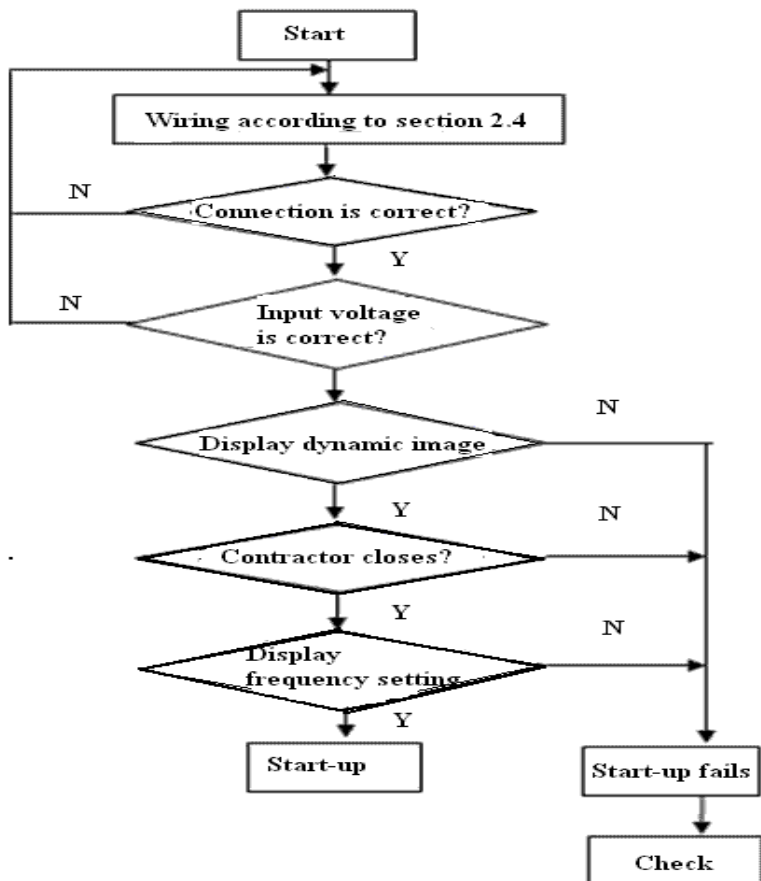

Fig. 3-12 Procedures of starting the driver for the first time

4 Function Parameters

4-1. Function parameter table

- “○” : Parameters can be changed while running
 “×” : Parameters can not be changed while running
 “*” : Parameters can only be read, user can not changed

1. Basic running parameters (Group P0)

Group P0: Basic running parameters					
Parameter	Name	Setting Range	Minum unit	Factory setting	Change
P0.00	Control mode selection	0: V/F control 1: open-loop vector control	1	0	×
P0.01	Frequency setting mode	0: Analog potentiometer in the panel 1 : Increase/Decrease key 2: digit setting 1, via keys on the panel 3: digit setting 2, via terminal UP/DOWN 4: digit setting 3, via serial port 5: VI analog input (VI-GND)	1	0	○

		6: CI analog input (CI-GND) 7 : Pulse input (PULSE) 8 : Combined setting mode (refer to P3.00)			
P0.02	Running frequency in digit mode	P0.19 High frequency limit ~ P0.20 low frequency limit	0.01HZ	50.00HZ	○
P0.03	Running command selection	0 : Running frequency via operation panel control 1: Terminal control 2 : serial port control	1	0	○
P0.04	Running direction setting	Unit's place: 0: jog forward via panel 1: jog reverse via panel Ten's place: 0 : permit reverse 1 : prohibit reverse	1	00	○
P0.05	Run forward/reverse dead time	0.0~120.0s	0.1s	0.1s	○

P0.06	Highest output frequency	50.00Hz ~ 500.00Hz	0.01Hz	50.00Hz	×
P0.07	Basic running frequency	1.00Hz ~ 500.00Hz	0.01Hz	50.00Hz	×
P0.08	Highest output voltage	1~480V	1V	Inverter rated voltage	×
P0.09	Torque boost	0.0%~30.0%	0.1%	2.0%	○
P0.10	Cut-off frequency for torque boost	0.00Hz ~ basic running frequency P0.07	0.00	25.00Hz	○
P0.11	Torque boost mode	0: manual 1: automatical	1	0	○
P0.12	Carrier frequency	1.0K~14.0K	0.1K	8.0K	×
P0.13	Acc/Dec direction selection	0: linear Acc/Dec 1: S curve Acc/Dec	1	0	×
P0.14	Low speed time of S ramp	10.0 % ~ 50.0 % (Acc/Dec time) P0.14 + P0.15 < 90 %	0.1%	20.0%	○
P0.15	Linear time of S ramp	10.0 % ~ 80.0 % (Acc/Dec time) P0.14 + P0.15 < 90 %	0.1%	60.0%	○
P0.16	Acc/Dec time unit	0: second 1: minute	0	0	×

P0.17	Acc time 1	0.1~6000.0	0.1	10.0	○
P0.18	Dec time 1	0.1~6000.0	0.1	10.0	○
P0.19	High frequency limit	Low frequency limit ~ highest output frequency P0.06	0.01Hz	50.00Hz	×
P0.20	Low frequency limit	0.00Hz ~ high frequency limit	0.01Hz	0.00Hz	×
P0.21	Running mode of low frequency limit	0: running at low frequency limit 1: stop	1	0	×
P0.22	V/F curve setting	0: constant torque curve 1 : torque-reducing curve 1 (1.2 order) 2: torque-reducing curve 2 (1.7 order) 3: torque-reducing curve 3 (2.0 order) 4 : multi-segment V/F curve	1	0	×
P0.23	V/F frequency value P1	0.00~P0.25	0.01Hz	0.00Hz	×
P0.24	V/F voltage value V1	0~ P0.26	0.1%	0.0%	×
P0.25	V/F frequency	P0.23 ~ P0.27	0.01Hz	0.00Hz	×

	value P2				
P0.26	V/F voltage value V2	P0.24 ~ P0.28	0.1%	0.0%	×
P0.27	V/F frequency value P3	P0.25 ~ P0.07 basic running frequency	0.01Hz	0.00Hz	×
P0.28	V/F voltage value V3	P0.26 ~ 100.0%	0.1%	0.0%	×

2. Reference frequency parameter (Group P1)

Group P1: reference frequency parameter					
Parameter	Name	Setting range	Minmum unit	Factory setting	Change
P1.00	Time constant of analog filter	0.01~30.00s	0.01s	0.20s	○
P1.01	VI Gain of reference frequency selsector	0.01~9.99	0.01	1.00	○
P1.02	min reference of VI	0.00~P1.04	0.01V	0.00V	○
P1.03	Frequency corresponding to min reference of VI	0.00 ~ high frequency limit	0.01Hz	0.00Hz	○

P1.04	Max reference of VI	P1.04~10.00V	0.01V	10.00V	○
P1.05	Frequency corresponding to max reference of VI	0.00 ~ high frequency limit	0.01Hz	50.00Hz	○
P1.06	Gain of reference frequency selector of CI	0.01~ 9.99	0.01	1.00	○
P1.07	Min reference of CI	0.00~ P1.09	0.01V	0.00V	○
P1.08	Frequency corresponding to min reference of CI	0.00 ~ high frequency limit	0.01Hz	0.00Hz	○
P1.09	Max reference of CI	P1.07 ~10.00V	0.01V	10.00V	○
P1.10	Frequency corresponding to max reference of CI	0.00 ~ high frequency limit	0.01Hz	50.00Hz	○

P1.11	Max input pulse frequency of PULSE	0.1~20.0K	0.1K	10.0K	○
P1.12	Min reference of PULSE	0.0~P1.14 (Max reference of PULSE)	0.1K	0.1K	○
P1.13	Frequency corresponding to min reference of PULSE	0.00 ~ high frequency limit	0.01Hz	0.00Hz	○
P1.14	Max reference of PULSE	P1.12 (Min reference of PULSE) ~ P1.11 (Max input frequency)	0.1K	10.0K	○
P1.15	Frequency corresponding to max reference of PULSE	0.00 ~ high frequency limit	0.01Hz	50.00Hz	○
P1.16	Input mode of CI	0: 4~20mA 1: 0~10V	-	0	○

3. Starting and Braking Parameters (Group P2)

Group P2: Starting and Braking Parameters					
Parameter	Name	Range	Minimum unit	Factory setting	Change
P2.00	Starting mode	0: Start from the starting frequency 1: Brake first and then start from the starting frequency 2: Start on the fly	1	0	×
P2.01	Starting frequency	0.20~20.00Hz	0.01Hz	0.50Hz	○
P2.02	Holding time of starting frequency	0.0~30.0s	0.1s	0.0s	○
P2.03	DC injection braking current at start	0.0~80.0%	0.1%	0%	○
P2.04	DC injection braking time at start	0.0~60.0s	0.1s	0.0s	○
P2.05	Stopping mode	0: Dec-to-stop 1: Coast-to-stop 2: Dec-to-stop +DC braking	1	0	×

P2.06	DC injection braking initial frequency at stop	0.0~15.00Hz	0.0Hz	3.00Hz	○
P2.07	DC injection braking waiting time at stop	0.0~60.0s	0.1s	0.0s	○
P2.08	DC injection braking current at stop	0.0~80.0%	0.1%	0.0%	○

4. Auxiliary running parameters (Group P3)

Group P3: Auxiliary running parameters					
Parameter	Name	Range	Minmum unit	Factory setting	Change
P3.00	Combination of frequency input	0: VI+CI 1: VI-CI 2 : External pulse reference + VI + Increase/Decrease key reference 3 : External pulse reference - VI - Increase/Decrease key reference 4 : External pulse reference + CI	1	0	×

		<p>5 : External pulse reference - CI</p> <p>6 : RS485 + VI + Increase/Decrease key reference</p> <p>7 : RS485 - VI - Increase/Decrease Key reference</p> <p>8 : RS485 + CI + Increase/Decrease key reference</p> <p>9 : RS485 - CI - Increase/Decrease key reference</p> <p>10 : RS485 + CI + External pulse reference</p> <p>11 : RS485 - CI - External pulse reference</p> <p>12 : RS485 + VI + External pulse reference</p> <p>13 : RS485 - VI - External pulse reference</p> <p>14 : VI + CI + Increase/Decrease ke</p>			
--	--	---	--	--	--

		<p>y reference + Digital setting</p> <p>15 : VI + CI – Increase/Decrease key reference + Digital setting</p> <p>16: MAX (VI, CI)</p> <p>17: MIN (VI, CI)</p> <p>18: MAX (VI, CI, PULSE)</p> <p>19: MIN (VI, CI, PULSE)</p> <p>20: VI, CI none-zero is valid, VI priority</p>			
P3.01	Parameter initialization locking up	<p>Unit's place:</p> <p>0: All parameters are allowed modifying</p> <p>1: Only P3.01 can be modified</p> <p>2: Only P0.02 and P3.01 can be modified</p> <p>Ten's place:</p> <p>0: disabled</p> <p>1: Restore to factory setting</p> <p>2: Clear fault record</p>	1	00	×
P3.02	Parameter cop	0: disabled	1	0	×

	y	1:parameter upload 2:parameter download Note:Function is still in developing			
P3.03	Auto energy-saving function	0: disabled 1: Enabled	1	0	×
P3.04	AVR function	0: disabled 1: enable all the time 2: Disabled in Dec process	1	0	×
P3.05	Gain of slip compensation	0~150%	1%	0%	×
P3.06	Jog operating frequency	0.10~50.00Hz	0.01Hz	5.00Hz	○
P3.07	Acc time of jog operation	0.1~60.0s	0.1s	5.0s	○
P3.08	Dec time of jog operation	0.1~60.0s	0.1s	5.0s	○
P3.09	Communication config	LED unit's place : baud rate selection 0: 1200BPS 1: 2400BPS 2: 4800BPS 3: 9600BPS 4: 19200BPS	1	054	×

		<p>5: 38400BPS LED ten's place: data format</p> <p>0: 1-7-2 format, no parity check</p> <p>1: 1-7-1 format, Odd</p> <p>2: 1-7-1 format, Even</p> <p>3: 1-8-2 format, None</p> <p>4: 1-8-1 format, Odd</p> <p>5: 1-8-1 format, Even</p> <p>6: 1-8-1 format, None</p> <p>(When use Modbus-RTU communication mode , please select data mode 3~6。)</p> <p>LED hundred's place: undefined</p>			
P3.10	Local address	<p>0~248</p> <p>0: broadcast address</p> <p>248: inverter as the host address</p>	1	1	×

P3.11	Delay for responding to control PLC	0.0~1000.0s 0.0 : Detection disabled	0.1s	0.0s	×
P3.12	Delay for responding to control PLC	0~1000ms	1	5ms	×
P3.13	Reference proportion of communication frequency	0.01~1.00	0.01	1.00	×
P3.14	Acc time 2	0.1~6000.0	0.1	10.0	○
P3.15	Dec time 2	0.1~6000.0	0.1	10.0	○
P3.16	Acc time 3	0.1~6000.0	0.1	10.0	○
P3.17	Dec time 3	0.1~6000.0	0.1	10.0	○
P3.18	Acc time 4	0.1~6000.0	0.1	10.0	○
P3.19	Dec time 4	0.1~6000.0	0.1	10.0	○
P3.20	Acc time 5	0.1~6000.0	0.1	10.0	○
P3.21	Dec time 5	0.1~6000.0	0.1	10.0	○
P3.22	Acc time 6	0.1~6000.0	0.1	10.0	○
P3.23	Dec time 6	0.1~6000.0	0.1	10.0	○
P3.24	Acc time 7	0.1~6000.0	0.1	10.0	○
P3.25	Dec time 7	0.1~6000.0	0.1	10.0	○
P3.26	Multi-frequency 1	Lower limit frequency~upper limit of frequency	0.01Hz	5.00Hz	○
P3.27	Multi-frequency 2	Lower limit frequency~upper li	0.01Hz	10.00Hz	○

		mit of frequency			
P3.28	Multi-frequency 3	Lower limit frequency~upper limit of frequency	0.01Hz	20.00Hz	○
P3.29	Multi-frequency 4	Lower limit frequency~upper limit of frequency	0.01Hz	30.00Hz	○
P3.30	Multi-frequency 5	Lower limit frequency~upper limit of frequency	0.01Hz	40.00Hz	○
P3.31	Multi-frequency 6	Lower limit frequency~upper limit of frequency	0.01Hz	45.00Hz	○
P3.32	Multi-frequency 7	Lower limit frequency~upper limit of frequency	0.01Hz	50.00Hz	○
P3.33	Jump frequency 1	0.00~500.00Hz	0.01Hz	0.00Hz	×
P3.34	Range of jump frequency 1	0.00~30.00Hz	0.01Hz	0.00Hz	×
P3.35	Jump frequency 2	0.00~500.00Hz	0.01Hz	0.00Hz	×
P3.36	Range of jump frequency 2	0.00~30.00Hz	0.01Hz	0.00Hz	×
P3.37	Jump	0.00~500.00Hz	0.01Hz	0.00Hz	×

	frequency 3				
P3.38	Range of jump frequency 3	0.00~30.00Hz	0.01Hz	0.00Hz	×
P3.39	Set running time	0~65.535K hour	0.001K	0.000K	○
P3.40	Accumulate running time	0~65.535K hour	0.001K	0.000K	*
P3.41	Display parameters selection 1	0000~FFFF Unit's place: b-09~b-12 Ten's place: b-13~b-16 Hundred's place: b-17~b-20 Thousand's place: b-21~b-24	1	0000	○
P3.42	Display parameters selection 2	0000~FFFF Unit's place: b-25~b-28 Ten's place: b-29~b-32 Hundred's place: b-33~b-36 Thousand's place: b-37~b-40	1	0000	○
P3.43	Display	0000~4040	1	0001	○

	parameters selection 3	Ten's place, unit's place : stop displayed parameter selection Thousand's place, hundred's place : run displayed parameter selection			
P3.44	Display coefficient without unit	0.1~60.0	0.1	1.0	○
P3.45	JOG/REV shift control mode	0: select JOG to start jog 1: select REV start reverse	1	0	×

5. Function parameters of terminal (Group P4)

Group P4: Function Parameters of Teriminal					
Parameter	Name	Range	Minmum unit	Factory setting	Change
P4.00	Function selection of input terminal X1	0 : Control terminal free 1: Multi-step speed control terminal 1 2 : Multi-step	1	1	×

		<p>speed control terminal 2</p> <p>3 : Multi-step speed control terminal 3</p> <p>4 : External terminal for forward jog operation</p> <p>5 : External terminal for reverse jog operation</p> <p>6 : Acc/Dec time terminal 1</p> <p>7 : Acc/Dec time terminal 2</p> <p>8 : Acc/Dec time terminal 3</p> <p>9 : 3-wire operation control</p> <p>10: Coast-to-stop (FRS)</p> <p>11 : External stop command</p> <p>12 : DC injection brak</p>			
--	--	--	--	--	--

		<p>g command DB</p> <p>13 : Inverter running prohibit</p> <p>14: Frequency ramp up (UP)</p> <p>15: Frequency ramp down (DOWN)</p> <p>16 : Acc/Dec prohibit</p> <p>17: Reset signal (clear fault)</p> <p>18: External fault signal normally open input</p> <p>19: Frequency selector 1</p> <p>20: Frequency selector 2</p> <p>21: Frequency selector 3</p> <p>22 : Terminal control mode is forcibly enabled</p> <p>23: Control mo</p>			
--	--	---	--	--	--

		<p>de selector 1</p> <p>24 : Control mode selector 2</p> <p>25 : Start traverse operation</p> <p>26 : Reset the traverse operation status</p> <p>27: Close-loop disabled</p> <p>28 : Pause the PLC operation</p> <p>29 : PLC disabled</p> <p>30: Reset PLC stopping status</p> <p>31: Frequency reference is input via CI</p> <p>32: Counter's trig signal input</p> <p>33: Counter's zero-cleaning signal input</p> <p>34 : External interrupt input</p> <p>35: Pulse freq</p>			
--	--	---	--	--	--

		uency input (only valid for X6) 36: Actual length clearing input			
P4.01	Function selection of input terminal X2	As above	1	2	×
P4.02	Function selection of input terminal X3	As above	1	3	×
P4.03	Function selection of input terminal X4	As above	1	10	×
P4.04	Function selection of input terminal X5	As above	1	17	×
P4.05	Function selection of input terminal X6	As above	1	18	×
P4.06	Function	As above	1	0	×

	selection of input terminal X7 FWD				
P4.07	Function selection of input terminal X8 REV	As above	1	0	×
P4.08	FWD/REV Operation mode selection	0 : 2-wire control mode 1 1 : 2-wire control mode 2 2 : 3-wire control mode 1 3 : 3-wire control mode 2	1	0	×
P4.09	UP/DN speed rate	0.01 — 99.99Hz/s	0.01	1.00Hz/s	○
P4.10	Bi-direction open-collector output terminal OC	0 : Inverter running (RUN) 1 : Frequency arriving signal (FAR) 2 : Frequency detection threshold (FDT 1) 3 : Frequency	1	0	×

		<p>detection threshold (FDT 2)</p> <p>4 : Overload pre-alarm (OL)</p> <p>5 : Inverter under voltage locking (LU)</p> <p>6 : External fault stop (EXT)</p> <p>7 : Output frequency arrive upper limit of (FH)</p> <p>8 : Output frequency arrive lower limit (FL)</p> <p>9: Inverter zero speed running</p> <p>10: Simple PLC Pause running finished</p> <p>11 : PLC is finished after one cycle running</p>			
--	--	---	--	--	--

		12:Specified counting value arriving 13 : Mid counting value arriving 14 : Inverter Ready running finished (RDY) 15 : Inverter fault 16 : Start frequency running time 17: Start DC injection braking time 18 : Stop braking time 19: High and lower limits of traverse operating frequency 20 : set running time arrive			
P4.11	Relay output s	As above	1	15	×

	elector				
P4.12	Detecting range of frequency arrive (FAR)	0.00~50.00Hz	0.01Hz	5.00Hz	○
P4.13	FDT1 (frequency) level	0.00 ~ upper limit of frequency	0.01Hz	10.00Hz	○
P4.14	FDT1 lag	0.00~50.00Hz	0.01Hz	1.00Hz	○
P4.15	FDT2 (frequency) level	0.00 ~ upper limit of frequency	0.01Hz	10.00Hz	○
P4.16	FDT2 lag	0.00~50.00Hz	0.01Hz	1.00Hz	○
P4.17	Analog output (AO)	0 : Output frequency (0~) 1 : Output current (0~2 times of rated current) 2 : Output voltage (0~1.2 inverter's rated voltage) 3: Bus voltage (0~800V) 4 : PID	1	0	○

		reference 5 : PID feedback 6: VI (0~10V) 7 : CI(0 ~ 10V/4~20mA)			
P4.18	Analog output (AO) gain setup	0.50~2.00	0.01	1.00	○
P4.19	AO output mode	0: 4~20mA 1: 0~10V	-	1	○
P4.20	DO output terminal	0 : Output frequency (0~ upper limit of of frequency) 1 : Output current (0~2 times motor rated current) 2 : Output voltage (0~1.2 inverter's rated voltage) 3: Bus voltage (0~800V) 4 : PID reference	1	0	○

		5 : PID feedback 6: VI (0~10V) 7 : CI(0 ~ 10V/4~20mA)			
P4.21	DO max pulse out frequency	0.1K ~ 20.0K (Max: 20KHz)	0.1KHz	10.0KHz	○
P4.22	preset counting value arriving	P4.23~9999	1	0	○
P4.23	Mid counting value arriving	0~P4.22	1	0	○
P4.24	Overload pre-alarm detection level	20%~200%	1	130%	○
P4.25	Delay time of over load pre-alarm	0.0~20.0s	0.1s	5.0s	○

6. Protective function parameters (Group P5)

Group P5: Protective function parameters					
Parameter	Name	Range	Minmum unit	Factory setting	Change
P5.00	Motor overload	0 : Inverter locking output	1	0	×

	protection mode selection	1: Disabled			
P5.01	Motor's overload protection coefficient	20~120%	1	100%	×
P5.02	Protection of over load at stall	0: Disabled 1: Enabled	1	1	×
P5.03	Over voltage point at stall	380V: 120~150% 220V: 110~130%	1%	140% 120%	○
P5.04	Auto current limiting threshold	110%~200%	1%	150%	×
P5.05	Frequeny decrease rate when current limiting	0.00~99.99Hz/s	0.01Hz/s	10.00Hz/s	○
P5.06	Auto current limiting selection	0 : Disabled in constant speed 1 : Enabled in constant speed Note: Enabled at Acc/Dec	1	1	×
P5.07	setting of the	0: Disabled	1	0	×

	restart after power off	1: Enabled			
P5.08	Holding time of restart after power off	0.0~10.0s	0.1s	0.5s	×
P5.09	Auto reset times of fault	0~10 0: No auto reset function (Note: overload and overheat have no recovery function)	1	0	×
P5.10	Auto reset interval of fault	0.5~20.0s	0.1s	5.0s	×

7. Fault recording parameter (Group P6)

Group P6: Fault recording parameter					
Parameter	Name	Description	Minmun unit	Factory setting	Change
P6.00	Previous fault record	Previous fault record	1	0	*
P6.01	Output frequency of previous fault	Output frequency of previous fault record	0.01Hz	0	*
P6.02	Setting	Setting frequency	0.01Hz	0	*

	frequency of previous fault	of previous fault record			
P6.03	Output current of previous fault	Output current of previous fault	0.1A	0	*
P6.04	Output voltage of previous fault	Output voltage of previous fault	1V	0	*
P6.05	DC injectiong bus voltage of previous fault	DC injectiong bus voltage of previous fault	1V	0	*
P6.06	Module temperature of previous fault	Module temperature of previous fault	10C	0	*
P6.07	2 latest fault record	2 latest fault record	1	0	*
P6.08	3 latest fault record	3 latest fault record	1	0	*
P6.09	4 latest fault record	4 latest fault record	1	0	*
P6.10	5 latest fault record	5 latest fault record	1	0	*
P6.11	6 latest fault record	6 latest fault record	1	0	*

8. Close-loop control parameters (Group P7)

Group P7: Close-loop control parameters					
Parameter	Name	Range	Minimum unit	Factory setting	Change
P7.00	Close-loop function selection	0: Disabled 1: Enabled	1	0	×
P7.01	Reference channel selection	0: Digit input 1: VI (0~10V) 2 : Analog reference by CI	1	1	○
P7.02	Feedback channel selection	0: VI (0~10V) 1 : Analog reference by CI 2: VI+CI 3: VI-CI 4: Min { VI, CI} 5: Max { VI, CI}	1	1	○
P7.03	Reference filter	0.01~50.00s	0.01s	0.50s	○
P7.04	Feedback filter	0.01~50.00s	0.01s	0.50s	○
P7.05	Set reference in digital mode	0.00~10.00V	0.01V	0.00V	○
P7.06	Min reference	0.0 ~ Max reference	0.1%	0.0%	○

		P7.08			
P7.07	Feedback value corresponding to min reference	0.0~100.0%	0.1%	0.0%	○
P7.08	Max reference	Min reference P7.06 ~ 100.0%	0.1%	100.0%	○
P7.09	Feedback value corresponding to max reference	0.0~100.0%	0.1%	100.0%	○
P7.10	Proportional KP	0.000~9.999	0.001	0.050	○
P7.11	Integral KI	0.001~9.999	0.001	0.050	○
P7.12	Sampling cycle T	0.01~10.00S	0.01	1.00	○
P7.13	Limits of deviation	0.0~20.0%	1%	2.0%	○
P7.14	Close loop adjustment characteristic	0:Forward 1:Reverse Note: relationship between reference temperature and speed	1	0	×
P7.15	Integral adjustment	0 : Stop integral	1	0	×

	selection	adjustment selection when the frequency reaches upper limit or lower limits 1 : Continue the integral adjustment selection when the frequency reaches high limit or lower limits			
P7.16	Close loop preset frequency	0 ~ upper limit of frequency	0.01Hz	0.00Hz	○
P7.17	Holding time of close loop	0.0~250.0s	0.1s	0.1s	×
P7.18	Threshold of zero-frequency operation	0.00 ~ 500.00Hz	0.01Hz	0.01Hz	×
P7.19	Hysteresis of zero-frequency operation	0.00 ~ 500.00Hz	0.01Hz	0.01Hz	×

9. Simple PLC operation parameters (Group P8)

Group P8: Simple PLC operation parameters					
Parameters	Name	Range	Minmum unit	Factory setting	Change
P8.00	Simple PLC operation mode selection	0000~1113 Unit's place: mode selection 0: Disabled 1: Stop after single cycle of operation 2: Holding at the final value after single cycle of operation 3: Operate continuously Ten's place: PLC restarting mode after stopping 0: Run again from stage 1 1: Continue to run from the stopping stage Hundred's place: Save at power off 0: Not saving 1: Save the time and frequency at po	1	0000	×

		<p>wer off</p> <p>Thousand's place :Selecting the unit of time</p> <p>0:second 1:minute</p>			
P8.01	Stage 1 setup	<p>000~621</p> <p>Unit's place of LED : frequency setup</p> <p>0: Multi (i=1~7) 1: Frequency is decide by P0.01</p> <p>Ten's place of LED: Operating direction selection</p> <p>0: Run forward 1: Run reverse 2 : Decided by operating instructions</p> <p>Hundred's place of LED: Acc/Dec time selection</p> <p>0: Acc/Dec time 1 1: Acc/Dec time 2 2: Acc/Dec time 3 3: Acc/Dec time 4</p>	1	000	○

		4: Acc/Dec time 5 5: Acc/Dec time 6 6: Acc/Dec time 7			
P8.02	Operating time in stage 1	0.1~6000.0	0.1	10.0	○
P8.03	Stage 2 setup	000~621	1	000	○
P8.04	Operating time in stage 2	0.1~6000.0	0.1	10.0	○
P8.05	Stage 3 setup	000~621	1	000	○
P8.06	Operating time in stage 3	0.1~6000.0	0.1	10.0	○
P8.07	Stage 4 setup	000~621	1	000	○
P8.08	Operating time in stage 4	0.1~6000.0	0.1	10.0	○
P8.09	Stage 5 setup	000~621	1	000	○
P8.10	Operating time in stage 5	0.1~6000.0	0.1	10.0	○
P8.11	Stage 6	000~621	1	000	○

	setup				
P8.12	Operating time in stage 6	0.1~6000.0	0.1	10.0	○
P8.13	Stage 7 setup	000~621	1	000	○
P8.14	Operating time in stage 7	0.1~6000.0	0.1	10.0	○

10. Traverse and measure function parameters (Group 9)

Group P9: Traverse and measure function parameters					
Parameters	Name	Range	Minum unit	Factory setting	Change
P9.00	Traverse function selection	0: Disabled 1: Enabled	1	0	×
P9.01	Traverse operation control mode	00~11 Unit's place of LED: Start mode 0: Auto mode 1: Manual mode Ten's place of LED: Amplitude control 0 : Variable	1	00	×

		amplitude 1 : Fixed amplitude			
P9.02	Pre-traverse frequency	0.00~500.00Hz	0.01Hz	0.00Hz	○
P9.03	Waiting time before pre-traverse frequency	0.0~3600.0s	0.1s	0.0s	○
P9.04	Traverse operating amplitude	0.0~50.0%	0.1%	0.0%	○
P9.05	Jitter frequency	0.0~50.0% (with reference to P9.04)	0.1%	0.0%	○
P9.06	Traverse operating cycle	0.1~999.9s	0.1s	10.0s	○
P9.07	Rising time of triangle wave	0.0~98.0% (with)	0.1%	50.0%	○
P9.08	Reference length	0.000 ~ 65.535(km)	0.001km	0.000km	○
P9.09	Actual length	0.0~65.535km (Saving at power off)	0.001km	0.000km	○
P9.10	Times of	0.001~30.000	0.001	1.000	○

	length				
P9.11	correction coefficient of length	0.001~1.000	0.001	1.000	○
P9.12	Perimeter of shaft	0.01~100.00cm	0.01cm	10.00cm	○
P9.13	Number of pulses per revolution	1~9999	1	1	○

11. Vector control parameters

(Group PA, Valid for F5 serial inverters)

Group PA: Vector Control Parameters					
Parameter	Name	Range	Minimum unit	Factory setting	Change
PA.00	Motor auto-turning	0: No turning 1 : Static turning	1	0	×
PA.01	Rated voltage of motor	0~400V	1	Dependent on inverter's model	×
PA.02	Rated current of motor	0.01 ~ 500.00A	0.01A	Dependent on	×

				inverter's model	
PA.03	Rated frequency of motor	1~99Hz	1Hz	Dependent on inverter's model	×
PA.04	Rated rotated speed of motor	1~9999 r/min	1r/min	Dependent on inverter's model	×
PA.05	Polarity of motor	2~48	1	Dependent on inverter's model	×
PA.06	Stator inductance of motor	0.1 ~ 5000.0mH	0.1mH	Dependent on inverter's model	×
PA.07	Rotor inductance of motor	0.1 ~ 5000.0mH	0.1mH	Dependent on inverter's model	×
PA.08	Exciting induction of motor	0.1 ~ 5000.0mH	0.1mH	Dependent on inverter's model	×
PA.09	Stator	0.001~50.000	0.001 Ω	Dependent	×

	resistance of motor	Ω		on inverter's model	
PA.10	Rotor resistance of motor	0.001~50.000 Ω	0.001 Ω	Dependent on inverter's model	×
PA.11	Over current protection coefficient of torque	0~15	1	15	×
PA.12	Percentage adjustment coefficient of speed deviation	50~120	1	85	×
PA.13	Integral adjustment coefficient of speed deviation	100~500	1	360	×
PA.14	Vector torque boost	100~150	1	80	×
PA.15	Reversed	0	0	0	×
PA.16	Reversed	1~5	1	4	×
PA.17	Reversed (excitation)	100~150	1	100	×

PA.18	Reversed	150	1	150	×
PA.19	Reversed	0~2	1	0	

12. Specail Application function parameters (Group PB)

Group PB: Specail Application function parameters					
Parameter	Name	Range	Minmum unit	Factory setting	Change
PB.00	Jog frequency source	0~4 0: P3.06 1 : Panel potentiometer 2: P0.02 3: VI 4: CI	0	0	○
PB.01	selection of forward/reverse dead time	0、1 0 : Dead time is enabled (Min 0.1S) 1: dead time can be set to 0 (P0.05=0.0S 、 P0.20 \geq 0.5Hz is needed)	1	0	○

13. Factory setting (Group PF)

Group PP: Factory Setting					
Parameter	Name	Range	Minmum unit	Factory setting	Change

PF.00	Default password	-	-	-	*
PF.01	User's password	0: With no password protection 0001 — 9999 : password protection	1	0000	○
PF.02	Software version	-	-	-	*
PF.03 ~ PF.10	Reversed	-	-	-	*

14. B—Monitor function parameters

B—Monitor function parameters					
Code	Name	Description	Minimum unit	Factory setting	Change
b-00	Output frequency	Present output frequency	0.01Hz		*
b-01	Reference frequency	Present reference frequency	0.01Hz		*
b-02	Output voltage	Valid value of present output voltage	1V		*
b-03	Output current	Valid value of present output current	0.1A		*
b-04	Bus voltage	Present DC bus voltage	1V		*
b-05	Module temperature	IGBT Temperature of heatsink	10C		*
b-06	Motor overl	Present motor overload	1r/min		*

	oad speed	speed			
b-07	Operating time	one continuously operating time of inverter	1 hour		*
b-08	Input/output terminal's status	Digital input/output terminal's status	—		*
b-09	Analog input VI	Value of analog input VI	0.01V		*
b-10	Analog input CI	Value of analog input CI	0.01V		*
b-11	External pulse input	Input value of external pulse range	1ms		*
b-12	Inverter rated current	Inverter rated current	0.1A		*
b-13	Inverter rated voltage	Inverter rated voltage	1V		*
b-14	no unit display	no unit display	1		*
b-15	Inverter power class	Inverter power class	-		*
b-16	Display present counter value	Display present counter value	-		*
b-17	Reversed	-	-		*

.....	Reversed	-	-		*
b-40	Reversed	-	-		*

Note : The corresponding relationship of monitor parameter input/output terminals and their status display are shown below:

“ / ” shows disabled (lamp off), “ **/** ” shows enabled (lamp on)

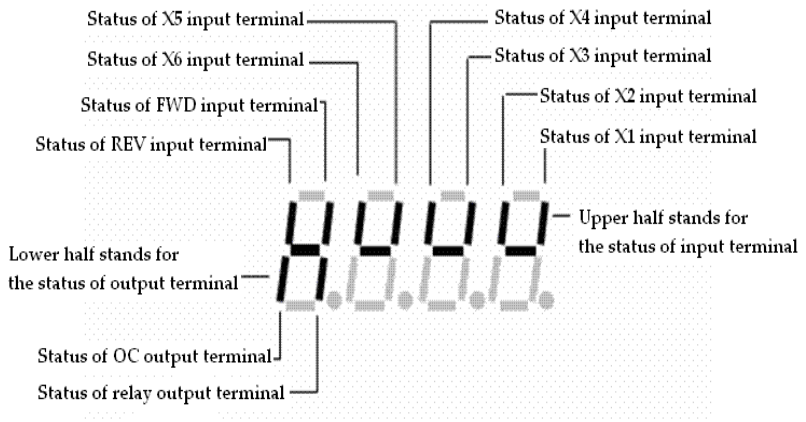

4-2. Parameter description

4-2-1. Basic operating function parameters (Group P0)

P0.00	Control mode selection	Range: 0~1	0
--------------	-------------------------------	-------------------	----------



0: V/F control

1: Open loop vector control

P0.01	Reference frequency selection	Range: 1~8	0
--------------	--------------------------------------	-------------------	----------

0: Panel analog potentiometer setting

1:  and  keys on the panel

You can set the reference frequency via  and  keys on the panel.

2: Keyboard digital

Initial frequency is the value of P0.02, to set the reference frequency via keyboard by modifying the value of P0.02.

3: Terminal UP/DOWN

Initial frequency is the value of P0.02, to set the frequency via terminal UP/DOWN.

4: Serial port (remote control)

Initial frequency is the value of P0.02, to set the frequency via serial port.

5: VI analog input (VI—GND)

The reference frequency is set by analog voltage input via terminal VI, the input voltage range is DC 0~10V. The corresponding relationship

between frequency and VI is decided by parameters P1.00~P1.05.

6: CI analog input (CI—GND)

The reference frequency is set by analog voltage/current of terminal CI and the input range is DC: 0~10V (if jumper JP3 is placed on “V” side), DC:4~20mA (if jumper JP3 is placed on “A” side). Then corresponding relationship between frequency and CI input is decided by parameter P1.06~P1.10.

7: Pulse input (PLUSE)

The reference frequency is set by pulse input via pulse terminal (can only be input via terminal X6). The corresponding relationship between frequency and PLUSE input is decided by parameters P1.11~P1.15.

8: Combination



Please refer to P3.00, to set the reference frequency via combination of channels.

P0.02	Digital frequency setting	Range: Upper limit of frequency~lower limit of frequency	50.00Hz
--------------	----------------------------------	---	----------------

When the reference frequency is set in digital mode (P0.01 = 1,2,3,4), The setting of P0.02 is the inverter’s initial frequency value.

P0.03	Methods of inputting operating commands	Range: 0,1,2	0
--------------	--	---------------------	----------

0: Panel control

Input operating commands via panel start or stop the inverter by pres   a  on the panel.

1: Terminal control

Input operating commands via externals such as FWD, REV, X1~X6 to start or stop the inverter.

2: Serial port control

To start or stop the inverter via RS485 port.

Note: The control modes can be controlled by modifying P0.03, while please be careful to use this method during operating.

P0.04	Set running direction	Range: 00~11	00
--------------	------------------------------	---------------------	-----------

The unit's place of this parameter is active with panel control mode to operate jog.

Unit's place of LED:

0: Jog forward in panel control mode

1: Jog reverse in panel control mode

Ten's place of LED:

0: Reverse running is permissible.

1: Reverse running is prohibit. The inverter will stop output when reverse command is input.

P0.05	Run forward/reverse dead time	Range: 0.0~120.0s	0.1s
--------------	--	--------------------------	-------------

It is the transition time at zero frequency time when the inverter switching its running direction, as shown in Fig.4-1 as t_1 .

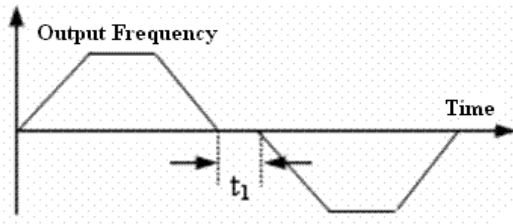

Fig. 4-1 Run forward/reverse dead time

P0.06	Max output frequency	Range: 50.00Hz~500.0Hz	50.00Hz
P0.07	Basic running frequency	Range: 1.00Hz~500.00Hz	50.00Hz
P0.08	Max output voltage	Range: 1~480V	Rated

The max output frequency is the highest permissible frequency of the inverter, as shown in Fig.4-2.

Basic running frequency is the lowest frequency when the inverter output the highest voltage and it is usually rated frequency of the motor, as shown in Fig4-2 as FB.

The max output voltage is the relevant output voltage when the inverter output basic running frequency and it is usually rated voltage of the motor, as shown in Fig.4-2 as Vmax.

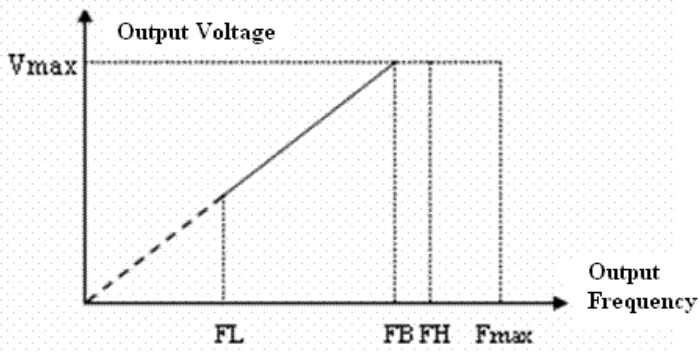
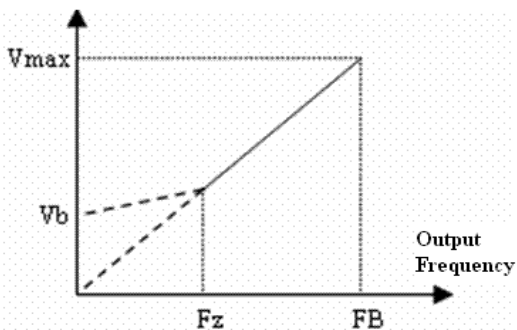

Fig. 4-2 Characteristic parameter

FH, FL are defined by P0.19 and P0.20 as upper limit of frequency and lower limit of frequency.

P0.09	Torque boost	Range: 0.0%~30.0%	2.0%
--------------	---------------------	--------------------------	-------------

In order to compensate the torque drop at low frequency, the inverter can boost the output voltage so as to boost the torque, the torque boost of constant torque curve and square torque curve are shown in Fig. 4-3 as a, b.



V_b : Manual torque boost voltage V_{max} : Max output voltage
 F_z : Cut-off frequency for torque boost F_B : Basic running frequency

(a) Torque boost of constant torque curve

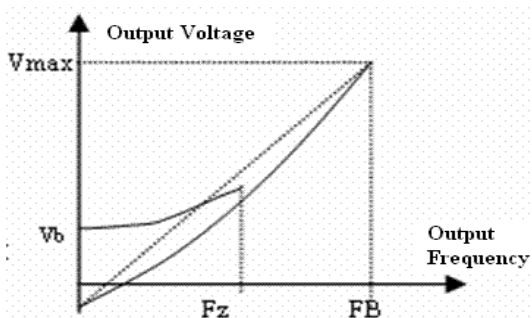

V_b : Manual torque boost voltage V_{max} : Max output voltage
 F_z : Cut-off frequency of torque boost F_B : Basic running frequency

(b) Torque boost of square torque curve

Fig. 4—3 Torque boost

P0.10	Cut-off frequency of torque boost	Range: 0.00Hz~Basic running frequency	25.00Hz
--------------	--	--	----------------

This function defines the cut-off frequency of torque boost, as shown in

Fig. 4-3 as Fz. Then cut-off frequency is suitable for any V/F curve defined by P0.02.

P0.11	Torque boost mode	Range: 0,1	0
--------------	--------------------------	-------------------	----------

0: Manual torque boost

Torque boost voltage is defined by parameter P0.09. The boost voltage is fixed while motor will be easily magnetism saturation with light load.

1: Auto torque boost

Torque boost voltage will change with the motor stator's current changes. The bigger the stator is, the higher the boost voltage.

$$\text{Boost Voltage} = \frac{\text{P0.09}}{100} \times \text{Motor's Rated Voltage} \times \frac{\text{Inverter's output current}}{2 \times \text{Inverter's rated current}}$$

P0.12	Carrier frequency	Range : 1.0K~14.0K	8.0K
--------------	--------------------------	---------------------------	-------------

Carrier frequency will effects the motor's noise and heat waste. The relationship among carier frequency, motor noise, leak current, and dist are shown below:

Carrier frequency	Decrease	Increase
Motor noise	↑	↓
Leakage current	↓	↑
Disturbance	↓	↑

Note : (1) In order to achieve better performances, the ratio of carrierfrequency to the maximum running frequency of the inverter should be less than 36.

- (2) When the carrier frequency is low, the current display value may has error.

P0.13	Acc/Dec mode	Range: 0、1	0
--------------	---------------------	-------------------	----------

0: Linear Acc/Dec mode

Output frequency increases or decreases according to a constant rate, as shown in Fig. 4-4.

1: S ramp Acc/Dec mode

Output frequency increases or decreases according to a S-shape curve, as shown in Fig.4-5.

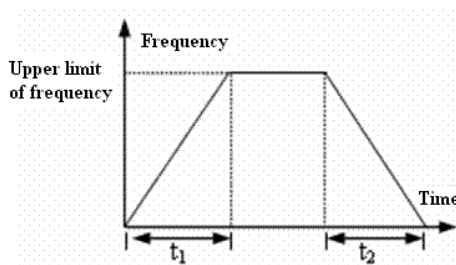

Fig.4-4 Linear Acc/Dec

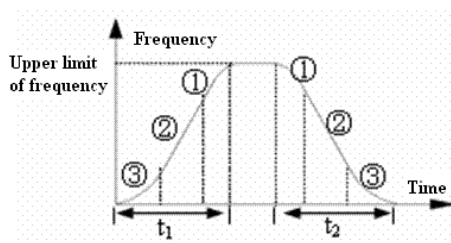

Fig.4-5 S-shape curve

P0.14	Low speed time of S ramp	Range: 10.0%~50.0% (Acc/Dec time) , P0.14+P0.15<90%	20.0%
P0.15	Linear time of S ramp	Range: 10.0%~80.0% (Acc/Dec time) , P0.14+P0.15<90%	60.0%

P0.14 and P0.15 are only active when Acc/Dec mode is S ramp Acc/Ecc mode (P0.13 = 1) and $P0.14+P0.15 < 90\%$.

Low speed time of S ramp is shown in Fig.4-5 as ③, where the changing rate of output frequency increases for 0.

Linear time of S ramp is shown in Fig.4-5 as ②, where the changing rate of output frequency is constant.

High speed time of S ramp is shown in Fig.4-5 as ①, where the changing rate of output frequency increases from 0. High speed time = $100\% - P0.14 - P0.15$.

Note: S ramp Acc/Dec mode is suitable for the start/stop of elevator, conveying belt, conveying load and so on .

P0.16	Acc/Dec time unit	Range: 0, 1	0
--------------	--------------------------	--------------------	----------

This function defines Acc/Dec time unit

0: second

1: minute

Note: (1) This function is active for all the process of Acc/Dec except jog running.

(2) Select second as time unit is recommended.

P0.17	Acc time 1	Range: 0.1~6000.0	10.0
P0.18	Dec time 1	Range: 0.1~6000.0	10.0

Acc time is the time taken for the motor to accelerate from 0 Hz to upper

limit of frequency, as t_1 in Fig.4-6; Dec time is the time taken for the motor to decelerate from upper limit of frequency to 0 Hz, as t_2 in Fig.4-6.

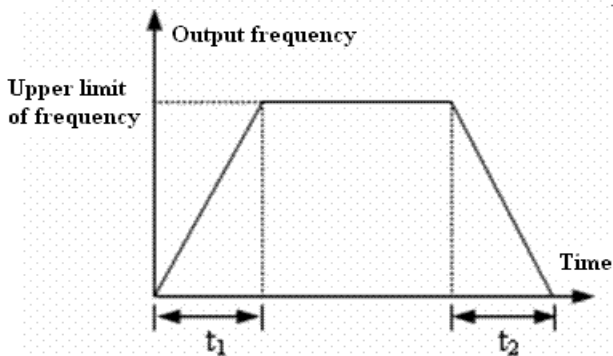

Fig.4-6 Acc/Dec time

- Note:** (1) This series inverter defines seven kinds of Acc/Dec time. Here only defines Acc/Dec time 1, Acc/Dec time 2~7 are defined in P3.14~P3.25.
- (2) Minute and second as the time unit of Acc/Dec time 1~7 can be selected via P0.09 and the default unit is second.

P0.19	Upper limit of frequency	Range : lower limit of frequency ~ max output frequency	50.00Hz
P0.20	Lower limit of frequency	Range: 0.00Hz~ upper limit of frequency	0.00HZ
P0.21	Lower mimit of frequency mode	Range: 0 : running with lower limit of frequency	0

		1: stop	
--	--	----------------	--

P0.19 and P0.20 define the upper and lower frequency of frequencies respectively, as shown in Fig.4-2 as FH and FL.

When the actual frequency is lower than the lower limit of frequency, inverter will accelerate with the accelerate time which you have set, and then after reaching the lower limit of frequency, inverter will running with the lower limit of frequency if the running mode is 0 and it will decelerate output frequency continuously until 0Hz with the running mode is 1.

P0.22	V/F curve setting	Range: 0~4	0
P0.23	V/F frequency value F1	Range: 0.00~P0.25	0.00Hz
P0.24	V/F voltage value V1	Range: 0~ P0.26	0.0%
P0.25	V/F frequency value F2	Range: P0.23 ~ P0.27	0.00Hz
P0.26	V/F voltage value V2	Range: P0.24 ~ P0.28	0.0%
P0.27	V/F frequency value F3	Range: P0.25 ~ P0.07 basic running frequency	0.00Hz
P0.28	V/F voltage value V3	Range: P0.26 ~ 100.0%	0.0%

This group of parameters defines the flexible V/F setting modes of this inverter to satisfy the requirement of different loads. Four fixed curves and one user-defined curve can be selected according to P0.22.

P0.22=0, V/F curve is constant torque curve, as shown in Fig.4-7 as curve 0.

P0.22=1, V/F curve is 1.2 order torque-reducing curve, as shown in Fig. 4-7 as curve 1.

P0.22=2, V/F curve is 1.7 order torque-reducing curve, as shown in Fig.4-7 as curve 2.

P0.22=3, V/F curve is 2.0 order torque-reducing curve, as shown in Fig.4-7 as curve 3.

To achieve best energy-saving effect, you can select 1,2 or 3 V/F curves according to the actual loads such as fans and pumps.

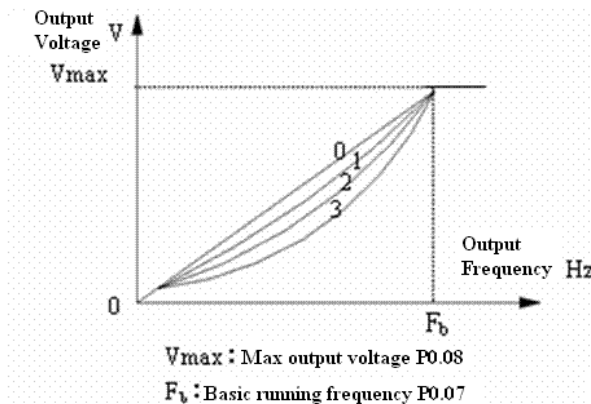

Fig.4-7 V/F curve

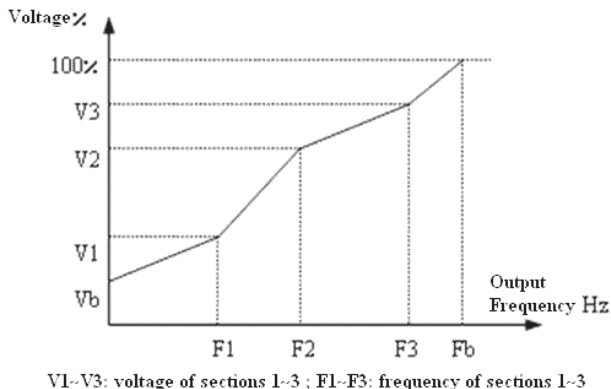

Fig. 4-8 User-defined V/F curve

When P0.22 is set to 4, you can define V/F curve via modifying (V1, F1), (V2, F2), (V3, F3) to satisfy the special load requirement, as shown in Fig.4-8. Torque boost is suitable for user-defined V/F curve. In Fig.4-8.

$$V_b = \text{Torque boost (P0.09)} \times V_1$$

4-2-2. Parameters of reference frequency (Group P1)

P1.00	Time constant of analog filter	Range: 0.01~30.00s	0.20s
--------------	---------------------------------------	---------------------------	--------------

It is the constant time of the filter that is for internal sample picking by inverter when reference frequency is set by external analog channel. When the wire is too long or the interference is serious which can lead to reference frequency becomes wavy, you can increase filter time to improve the situation. The bigger the time constant is, the higher the immunity level, but the response time is prolonged with the increase of the time constant. That is, the smaller the time constant is, the shorter the response time, but the lower the immunity level.

P1.01	Gain of reference frequency selector of VI	Range: 0.01~9.99	1.00
P1.02	Min reference of VI	Range: 0.00~P1.04	0.00V
P1.03	Frequency corresponding to min reference of VI	Range: 0.00~upper limit of frequency	0.00Hz
P1.04	Max reference of VI	Range: P1.04~10.00V	10.00V
P1.05	Frequency corresponding to max reference of VI	Range: 0.00~upper limit of frequency	50.00Hz
P1.06	Gain of reference frequency selector of CI	Range: 0.01~ 9.99	1.00
P1.07	Min reference of CI	Range: 0.00~ P1.09	0.00V
P1.08	Frequency according to min reference of CI	Range: 0.00~upper limit of frequency	0.00Hz
P1.09	Max frequency of CI	Range: P1.07 ~10.00V	10.00V
P1.10	Frequency according to max reference of CI	Range: 0.00~upper limit of frequency	50.00Hz
P1.11	Max input pulse frequency of PULSE	Range: 0.1~20.0K	10.0K
P1.12	Min reference of PULSE	Range: 0.0~P1.14	0.1K
P1.13	Frequency corresponding to min reference of PULSE	Range: 0.00~upper limit of frequency	0.00Hz
P1.14	Max reference of PULSE	Range: P1.12~P1.11	10.0K
P1.15	Frequency corresponding to max reference of PULSE	Range: 0.00~upper limit of frequency	50.00Hz
P1.16	Input mode of CI	Range: 0、 1	0

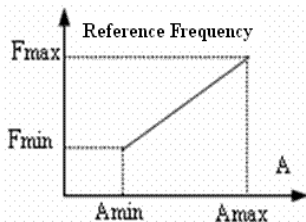

(1) Positive

A : Reference of CI A_{min} : Min reference
 A_{max} : Max reference

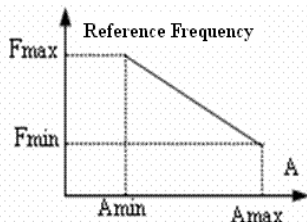

(2) Negative

F_{min} : Frequency corresponding to
 min reference

F_{max} : Frequency corresponding to
 max reference

The relationship between PULSE and reference frequency is shown below:

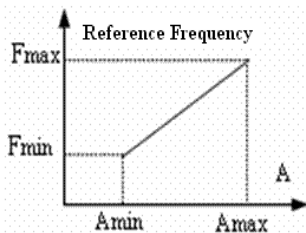

(1) Positive

A : Reference
 of PULSE A_{min} : Min reference
 A_{max} : Max reference

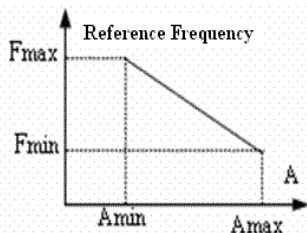

(2) Negative

F_{min} : Frequency corresponding to
 min reference

F_{max} : Frequency corresponding to
 max reference

4-2-3. Starting and braking parameters (Group P2)

P2.00	Starting mode	Range: 0,1,2	0
--------------	----------------------	---------------------	----------

0: Start from the starting frequency

Inverter starts at the starting frequency (P2.01) within the holding time of starting frequency (P2.02).

1: Brake first and then start

Brake with DC braking current (P2.03) within braking time (P2.04) and then start at starting frequency.

2: Start on the fly

When P2.00 is set to 2, it is suitable for repowering after instantaneous power off or restarting after external fault. As shown in Fig.4-9.

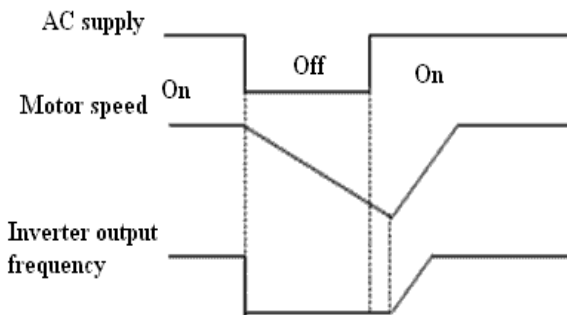

Fig.4-9 Start on the fly

- Note:**
- (1) Starting mode 0: It is recommended in general application or when the inverter drives synchronous motor.
 - (2) Starting mode 1: It is suitable for starting the motor that is running in forward or reverse with small inertial load, and it is not recommended for big inertial load.
 - (3) Starting mode 2: It is suitable for starting the motor that is in free stop or for restarting after instantaneous power off.

P2.01	Starting frequency	Range: 0.20~20.00Hz	0.50 Hz
P2.02	Holding time of starting frequency	Range: 0.0~30.0S	0.0S

Starting frequency points to the initial frequency when inverter starts, as shown in Fig.4-10 as F_s . Holding time of starting frequency points to the holding time while inverter is running at the starting frequency, as shown in Fig.4-10 as t_1 .

Note: Starting frequency is not stricted by the lower limit of frequency

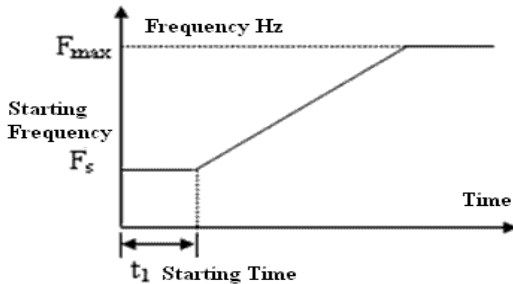

Fig.4-10 Starting frequency and starting time

P2.03	DC injection braking current at start	Range: 0~80(%)	0(%)
P2.04	DC injection braking time at start	Range: 0.0~60.0S	0.0S

When P2.00 is set to 1, P2.03 and P2.04 are active, as shown in Fig. 4-11

DC injection braking current at start is a percentage value of inverter's rated current. There is no DC injection braking when the braking time is 0.00s.

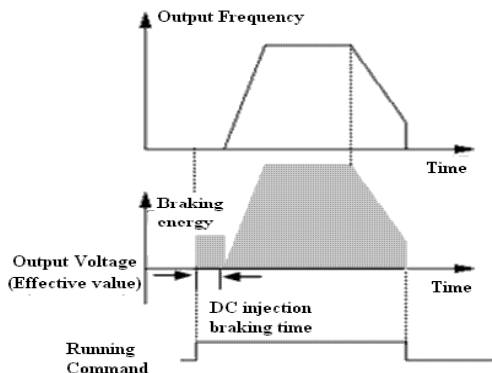

Fig.4-11 Starting mode 1

Command

Fig. 4-12 Dec-to-stop+DC injection braking

P2.05	Stopping mode	Range: 0,1,2	0
--------------	----------------------	---------------------	----------

0: Dec-to-stop

After receiving the stopping command, the inverter reduces its output frequency within its Dec time and stops when the frequency becomes 0.

1: Coast to stop

After receiving the stopping command, the inverter stops output power immediately and the motor stops according to mechanical inertia.

2: Dec-to-stop+DC injection braking

After receiving the stopping command, the inverter reduces its output frequency according to Dec time and then start to DC injection braking

after the output frequency reaching the initial frequency of braking at stop as in P2.06.

P2.06	DC injection braking initial frequency at stop	Range: 0.0~15.00Hz	3.00Hz
P2.07	DC injection braking time at stop	Range: 0.0~60.0S	0.0S
P2.08	injection braking current at stop	Range: 0~80 (%)	0(%)

P2.08 refers to the set of DC injection braking current at stop which is the percentage value of inverter's rated current. There is no DC injection braking when the braking time is 0.0, as shown in Fig.4-12.

4-2-4. Auxiliary running parameters (Group P3)

P3.00	Combination of frequency setting	Range: 0~20	0
--------------	---	--------------------	----------

When P0.01 (Frequency setting mode) is set to 8, combination of frequency setting can be set through this parameter.

- 0: VI+CI
- 1: VI-CI
- 2: External pulse reference+VI+Increase/Decrease key reference
- 3: External pulse reference-VI-Increase/Decrease key reference
- 4: External pulse reference+CI
- 5: External pulse reference-CI
- 6: RS485+VI+Increase/Decrease key reference
- 7: RS485-VI-Increase/Decrease key reference

- 8: RS485+CI+Increase/Decrease key reference
 9: RS485-CI-Increase/Decrease key reference
 10: RS485+CI+External pulse reference
 11: RS485-CI-External pulse reference
 12: RS485+VI+External pulse reference
 13: RS485-VI-External pulse reference
 14: VI+CI+Increase/Decrease key reference+Digital setting
 P0.02
 15: VI+CI-Increase/Decrease key reference+Digital setting
 P0.02
 16: MAX (VI, CI)
 17: MIN (VI, CI)
 18: MAX (VI, CI, PLUSE)
 19: MIN (VI, CI, PLUSE)
 20: VI, CI is active, VI is priority

P3.01	Parameter initialization locking up	Range: LED unit's place 0~2, LED ten's place 0~2	00
--------------	--	---	-----------

LED unit's place

- 0: All the parameters are allowed modifying.
 1: Only P3.01 can be modified.
 2: Only P0.02 and P3.01 can be modified.

LED ten's place

- 0: Disabled
 1: Restore to factory setting
 2: Clear fault record

Note: (1) The factory setting of P3.01 is 0 and allow all the parameters to

be modified. After modifying this parameter, please set it as 0 if you want to modify other parameters. Also, you can set protective grade.

- (2) P3.01 will be changed to 0 automatically after restoring to factory setting.

P3.02	Parameter copy	Range: 0,1,2	0
--------------	-----------------------	---------------------	----------

0: Disabled

1: Parameter up load: Up load the parameters from inverter to remote operation panel.

2: Parameter down load: Down load the parameters from remote operation panel to inverter.

Note : This function is still in developing.

P3.03	Auto energy-saving function	Range: 0,1	0
--------------	------------------------------------	-------------------	----------

0: Disabled

1: Enabled

Inverter can regulate output voltage through detecting load current to achieve energy-saving when the motor running without load or with light load. Auto energy-saving is suitable for the application with steady load and speed.

P3.04	AVR function	Range: 0,1,2	0
--------------	---------------------	---------------------	----------

AVR function points to regulating voltage automatically. When the input voltage of inverter fluctuates, AVR function can keep it steady.

In Dec-to-stop process, if AVR is disabled, the Dec time is short and the running current is big; if AVR is enabled, the motor decelerates steadily,

the running current is small and the Dec time is prolonged.

0: Disabled

1: Enabled

2: Disabled in Dec process

P3.05	Gain of slip compensation	Range: 0~150(%)	0(%)
--------------	----------------------------------	------------------------	-------------

This function can make suitable regulation for inverter's output frequency according to the load changes, and control the speed at a certain value with dynamic compensation for slip frequency of asynchronous motor. If use auto-torque boost function in addition, better low speed moment characteristic can be get. As shown in Fig.4-13.

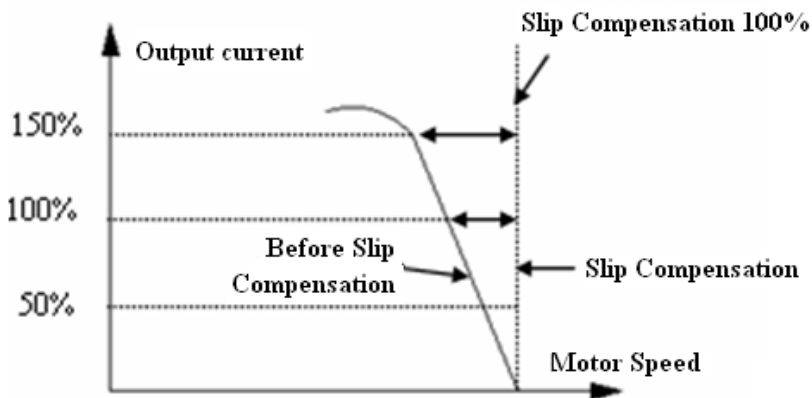

Fig.4-13 Slip Compensation

P3.06	Jog operating frequency	Range: 0.10~50.00Hz	5.00Hz
P3.07	Acc time of jog operation	Range: 0.1~60.0S	5.0S

P3.08	Dec time of jog operation	Range: 0.1~60.0S	5.0S
--------------	----------------------------------	-------------------------	-------------

Jog operating frequency has the highest priority. No matter what status the inverter is in, once there is a jog operating command input, the inverter will run into jog operating frequency within Acc/Dec time of jog operation, as shown in Fig.4-14.

Acc time of jog operation means the time needed for inverter from 0 Hz to upper limit of frequency, Dec time of jog operation means the time needed for inverter from upper limit of frequency to 0 Hz.

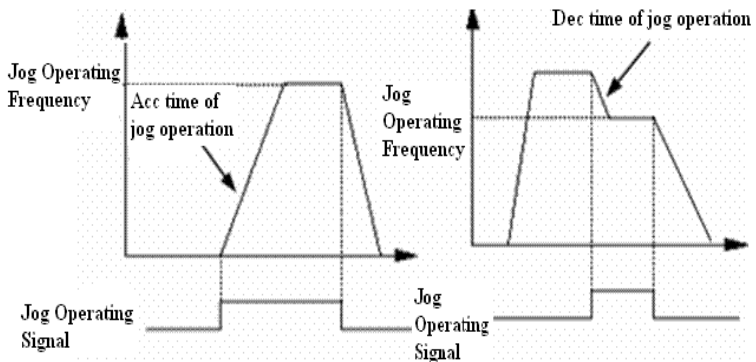

Fig 4-14 Jog operation

- Note:**(1) Jog operation can be controlled by panel, terminal and serial port.
- (2) If jog operation command has been canceled, the inverter will stop according to Dec-to-time.

P3.09	Communication configuration	Range: 000~155	054
--------------	------------------------------------	-----------------------	------------

You can change baud rate, digital format and communication mode by setting unit's place, ten's place and hundred's place of P3.09.

Unit's place of LED: Set baud rate, the values are shown below:

- 0: 1200BPS
- 1: 2400BPS
- 2: 4800BPS
- 3: 9600BPS
- 4: 19200BPS
- 5: 38400BPS

Ten's place of LED: Set digital format, the values are show below:

- 0: 1-7-2 format, no parity check; 1 stop bit , 7 data bits, 2 stop bits, no parity check.
- 1: 1-7-1 format, odd; 1 stop bit, 7 data bits, 1 stop bits, odd
- 2: 1-7-1 format, even; 1 stop bit, 7 data bits, 1 stop bit, even
- 3: 1-8-2 format, no parity check; 1 stop bit, 8 data bits, 2 stop bits, no parity check.
- 4: 1-8-1 format, odd; 1 stop bit, 8 data bits, 1 stop bit, odd
- 5: 1-8-1 format, even; 1 stop bit, 8 data bits, 1 stop bit, even
- 6: 1-8-1 format, no parity check; 1 stop bit, 8 data bits, 1 stop bit, no parity check.

Hundred's place of LED : undefined

Note: when choose Modbus-RTU communication mode, you should select digital format 3~6.

P3.10	Local address	Range: 0~248	1
--------------	----------------------	---------------------	----------

This parameter is used for identify the inverter's address in serial communication.

0 is the broadcast address. If take inverter as a slave, it will receive the

command with 0 as broadcast address and will not answer the PC.
248 is the address with inverter as a host. If take inverter as host and set P3.10 as 248, it can send broadcast command to other inverters to realize multi-machine .

P3.11	Time threshold for judging communication status	Range: 0.0~1000.0S	0.0S
--------------	--	---------------------------	-------------

When serial port failed and the duration over the reference value, the inverter will judge it as communication fault.
When set the value as 0, the inverter will not detect the serial communication port and this function disabled.

P3.12	Host PC response delay	Range: 0~1000ms	5ms
--------------	-------------------------------	------------------------	------------

It refers to time from inverter's serial port receiving and executing the command of host PC to returning response to it.

P3.13	Reference proportion of communication frequency	Range: 0.01~1.00	1.00
--------------	--	-------------------------	-------------

This parameter is used for setting the proportion coefficient according to frequency setting command which is receiving by inverter through RS485, the actual running frequency equivalent to this parameter multiply the frequency value receiving through RS485.

This parameter can also set running frequency proportion of several inverters in multimachine linkage mode.

P3.14	Acc time 2	Range: 0.1~6000.0	10.0
P3.15	Dec time 2	Range: 0.1~6000.0	10.0
P3.16	Acc time 3	Range: 0.1~6000.0	10.0
P3.17	Dec time 3	Range: 0.1~6000.0	10.0
P3.18	Acc time 4	Range: 0.1~6000.0	10.0
P3.19	Dec time 4	Range: 0.1~6000.0	10.0
P3.20	Acc time 5	Range: 0.1~6000.0	10.0
P3.21	Dec time 5	Range: 0.1~6000.0	10.0
P3.22	Acc time 6	Range: 0.1~6000.0	10.0
P3.23	Dec time 6	Range: 0.1~6000.0	10.0
P3.24	Acc time 7	Range: 0.1~6000.0	10.0
P3.25	Dec time 7	Range: 0.1~6000.0	10.0

Seven kinds of Acc/Dec time can be defined, and the inverter's Acc/Dec time 1~7 can be selected by different combination of control terminals. Please refer to the introductions of P4.00~P4.05 for the definitions of terminals used to select Acc/Dec time, also, you can refer to Acc/Dec time defined in P0.17 and P0.18.

P3.26	Multi-frequency 1	Range: lower limit of frequency~ upper limit of frequency	5.00Hz
P3.27	Multi-frequency 2	Range: lower limit of frequency~ upper limit of frequency	10.00Hz
P3.28	Multi-frequency 3	Range: lower limit of frequency~ upper limit of frequency	20.00Hz
P3.29	Multi-frequency 4	Range: lower limit of frequency~ upper limit of frequency	30.00Hz
P3.30	Multi-frequency 5	Range: lower limit of frequency~ upper limit of frequency	40.00Hz

P3.31	Multi-frequency 6	Range: lower limit of frequency~ upper limit of frequency	45.00Hz
P3.32	Multi-frequency 7	Range: lower limit of frequency~ upper limit of frequency	50.00Hz

These frequencies will be used in multi-step speed operation and simple PLC operation, please refer to the instructions of P4.00~P4.05 and P8.

P3.33	Jump frequency 1	Range: 0.00—500.00Hz	0.00Hz
P3.34	1 Range of jump frequency 1	Range: 0.00—30.00Hz	0.00Hz
P3.35	Jump frequency 2	Range: 0.00—500.00Hz	0.00Hz
P3.36	Range of jump frequency 2	Range: 0.00—30.00Hz	0.00Hz
P3.37	Jump frequency 3	Range: 0.00—500.00Hz	0.00Hz
P3.38	Range of jump frequency 3	Range: 0.00—30.00Hz	0.00Hz

P3.33~P3.38 define the functions that will let output frequency of the inverter avoid resonant point of mechanical load. The reference frequency of the inverter can do jump operation in the certain range of some jump frequency point, as shown in Fig. 6-15, you can define three ranges of jump frequency at most.

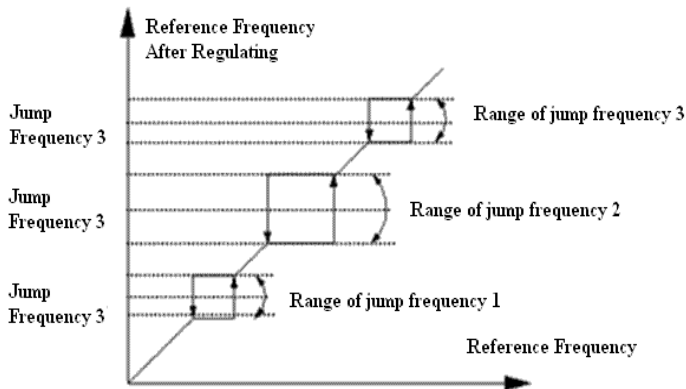

Fig.4-15 Jump frequency and range

P3.39	Set running time	Range: 0~65.535K hour	0.000K
P3.40	Accumulate running time	Range: 0~65.535K hour	*

Acculate running time to reach the reference time (P3.39), the inverter will output signal, refer to function instruction of P4.08~P4.09.

P3.40 refers to the accumulating running time from factory till now.

P3.41	Display parameters selection 1	Range: 0000~FFFF	0000
--------------	---------------------------------------	-------------------------	-------------

P3.41 controls that if the monitor parameters b-09 ~ b-24 can be displayed in parameter group by four figures. The parameter values are in hex which should be changed to binary ones according to the sequence of monitor parameters when using. The relationship between four figures and parameters are shown in Fig.4-16.

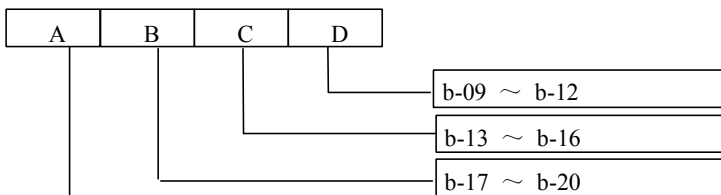
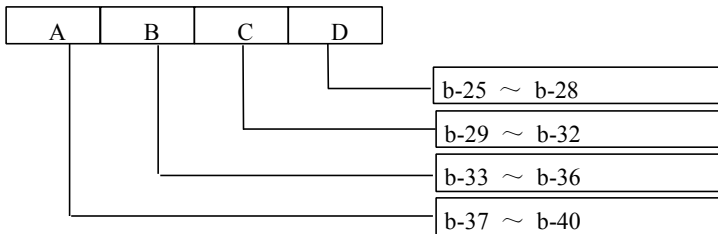

Fig.4—16 Display parameters selection 1

**Note: A: Thousand's place, B: Hundred's place,
C: Ten's place, D: Unit's place**

P3.42	Display parameters selection 2	Range: 0000~FFFF	0000
--------------	---------------------------------------	-------------------------	-------------

P3.42 controls that if b-25~b-40 can be displayed in parameter group by four figures. The parameter values are in hex which should be changed to binary ones according to the sequency of monitor parameters when using. The relationship between four figures and parameters are shown in Fig. 4-17.

**Fig.4—17 Display parameters selection 2**

(Refer to P73 for b-09 ~ b-40)

**Note: A: Thousand's place, B: Hundred's place,
C: Ten's place, D: Unit's place**

P3.43	Display parameters 3	Range: 0000~4040	0001
--------------	-----------------------------	-------------------------	-------------

Ten's place, unit's place: used to set stop status

Thousand's place, hundred's place: used to set running status

Example: When you want to let the inverter display current value in



running status and display DC injection bus voltage value, you can set P3.43=0304. You can also press the key to view other monitor parameters.

P3.44	Display coefficient without unit	Range: 0.1~60.0	1.0
--------------	---	------------------------	------------

P3.44: It is used to set proportion value between display value and output frequency of monitor parameter b-14.

Display value of b-14=Output frequency of inverter×P3.44

P3.45	JOG/REV shift control mode	Range: 0,1	0
--------------	---------------------------------------	-------------------	----------

P3.45 is used to select the usage of JOG/REV key in the panel, the references are shown below:

0: select to JOG

1: select to REV

4-2-5. Function parameters of terminal (Group P4)

P4.00	Function selection of input terminal X1	Range: 0~37	1
P4.01	Function selection of input terminal X2	Range: 0~37	2
P4.02	Function selection of input terminal X3	Range: 0~37	3
P4.03	Function selection of input terminal X4	Range: 0~37	10

P4.04	Function selection of input terminal X5	Range: 0~37	17
P4.05	Function selection of input terminal X6	Range: 0~37	18
P4.06	Function selection of input terminal X7	Range: 0~37	0
P4.07	Function selection of input terminal X8	Range: 0~37	0

Multi-function input terminals X1~X8 support various functions which you can select freely to satisfy your requirement. You can define the function of X1~X8 by setting the value of P4.00~P4.07, refer to Table 4-1 for details, Among these terminals, X7 corresponds to FWD and X8 corresponds to REV.

Table 4-1 Multi-function selection

Setting	Functions	Setting	Functions
0	Control terminal leave unused	19	Frequency selector 1
1	Multi-step speed control terminal 1	20	Frequency selector 2
2	Multi-step speed control terminal 2	21	Frequency selector 3
3	Multi-step speed control terminal 3	22	Terminal control mode is forcibly enabled
4	External terminal for forward jog operation	23	Control mode selector 1
5	External terminal for reverse jog operation	24	Control mode selector 2
6	Acc/Dec time terminal 1	25	Start traverse operation
7	Acc/Dec time terminal 2	26	Reset traverse operation

8	Acc/Dec time terminal 3	27	Close-loop disabled
9	3-wire operation control	28	Pause the PLC operation
10	Coast-to-stop (FRS)	29	PLC disabled
11	External stop command	30	Reset PLC stopping status
12	DC injection braking command DB	31	Frequency reference is input via CI
13	Inverter running prohibit	32	Counter's trig signal input
14	Frequency ramp up (UP)	33	Counter's zero-cleaning signal input
15	Frequency ramp down (DOWN)	34	External interrupt input
16	Acc/Dec prohibit	35	Pulse frequency input (only valid for X6)
17	Reset signal (clear fault)	36	Actual length clearing input
18	External fault signal normally open input	37	

Introductions of the functions shown in Table4-1:

1~3: Multi-step speed control terminals. Up to 7 speed reference can be set by different ON/OFF (open/close) combination of the function terminals, at the same time, you can select corresponding Acc/Dec time.

Table 4-2 On/Off combination of function terminals

K₃	K₂	K₁	Frequency setting	Acc/Dec time
OFF	OFF	OFF	Common running frequency	Acc/Dec time 1
OFF	OFF	ON	Multi-step frequency 1	Acc/Dec time 1
OFF	ON	OFF	Multi-step frequency 2	Acc/Dec time 2

OFF	ON	ON	Multi-step frequency 3	Acc/Dec time 3
ON	OFF	OFF	Multi-step frequency 4	Acc/Dec time 4
ON	OFF	ON	Multi-step frequency 5	Acc/Dec time 5
ON	ON	OFF	Multi-step frequency 6	Acc/Dec time 6
ON	ON	ON	Multi-step frequency 7	Acc/Dec time 7

The above frequencies can be used in multi-step speed running and simple PLC running, this manual take multi-step speed running as an example.

The definition of X1, X2 and X3 are shown below:

P4.00=1, P4.01=2, P4.03=3, X1, X2 and X3 can be used to achieve multi-step speed operation, as shown in Fig.4-18.

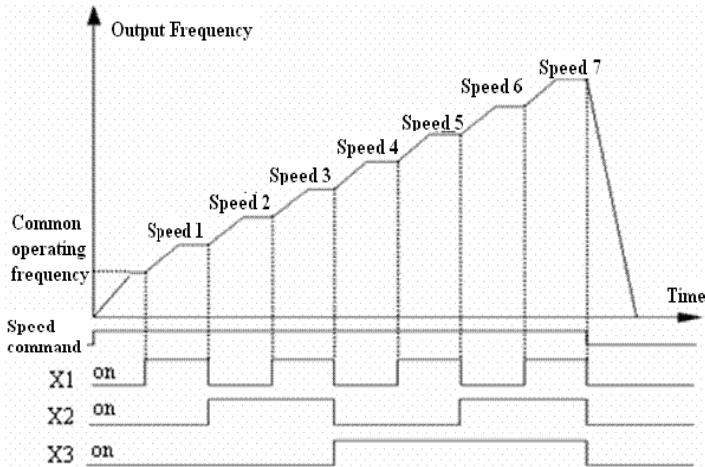

Fig.4-18 Multi-step speed operation

In Fig.4-19 terminal control is selected, the operating direction is

controlled by K_7 、 K_8 . In Fig.4-18, Common operating frequency or 1~7 multi-step frequency can be controlled by different combination of K_1 , K_2 , K_3 .

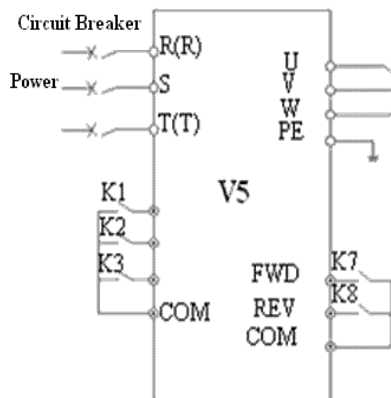

Fig.4—19 Wire of multi-step speed operation

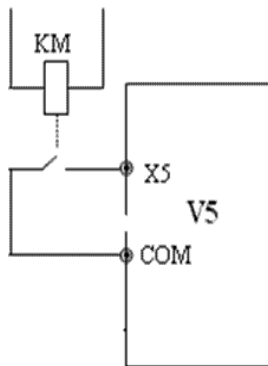

Fig.4-20 External device fault input

4~5: External terminals control jog operation JOGP/JOGR. When choose terminal control (P0.03=1), JOGP is used as forward jog operation , JOGR is used as reverse jog operation. Jog operating frequency and jog Acc/Dec time are defined in P3.06~P3.08.

6~8: Acc/Dec time selection

Table 4-3 Acc/Dec time selection

Terminal 3	Terminal 2	Terminal1	Acc/Dec time selection
OFF	OFF	OFF	Acc time 1/Dec time 1
OFF	OFF	ON	Acc time 2/ Dec time 2
OFF	ON	OFF	Acc time 3/ Dec time 3
OFF	ON	ON	Acc time 4/ Dec time 4

ON	OFF	OFF	Acc time 5/ Dec time 5
ON	OFF	ON	Acc time 6/ Dec time 6
ON	ON	OFF	Acc time 7/ Dec time 7

Through the ON/OFF combination of Dec time terminal, you can select dec time 1~7.

9: 3-wire operation control, refer to functional instruction of P4.08.

10:Coast-to-stop (FRS) , this function has the same meaning as the description in P2.05, while here it is achieved by terminal controlling which is convenient for remote control.

11:External stop command, this command is valid for all the running channels and it can stop the inverter according to the setting mode in P2.05.

12: DC injection braking command DB, the terminal can be used to perform DC injection braking to the motor that is running so as to realize the emergent stop and accurate location of the motor. Initial braking frequency, braking time and braking current are defined by P2.06~P2.08. Braking time is the greater value between P2.07 and the effective continuous time defined by this control terminal.

13: Inverter running prohibit. When the terminal is enabled, the inverter that is operating will coast to stop and it is prohibited to restart. This function is mainly used in application with requirements of safety protection.

14~15: Frequency ramp up (UP)/Frequency ramp down(DOWN)

The terminal can be used to increase or decrease the frequency. Its function is the same with operating keys on the panel, which enables remote control. This terminal is enabled when P0.01=3. Increase or decrease rate is determined by P4.09.

16: Acc/Dec prohibit. The terminal can make the motor operate at present speed without being influenced by external signal (except stopping command).

Note: Disabled in normal dec-to-stop.

17: Reset signal. The inverter can be reset via this terminal when the inverter has a fault. The function of this terminal is the same with that of  on the panel.

18: External fault signal normally open input. The fault signal of external equipment can be input via the terminal, which is convenient for the inverter to monitor the external equipment. Once the inverter receives the fault signal, it will display “E-13”. Refer to Fig.4-20.

19~21: Frequency selector 1. Different ON/OFF combination of terminals 19, 20 and 21 can select reference frequency as shown in Table 4-4. The inverter will be active this function and P0.01 later.

Table 4-4 Frequency selector

Frequency selector 3	Frequency selector 2	Frequency selector 1	Frequency selector
OFF	OFF	OFF	Hold the setting
OFF	OFF	ON	Digital setting
OFF	ON	OFF	Terminal UP/DOWN setting
OFF	ON	ON	Serial port setting
ON	OFF	OFF	VI
ON	OFF	ON	CI
ON	ON	OFF	PULSE
ON	ON	ON	Combination setting (refer to P3.01)

22: Terminal control mode is forcibly enabled. When this terminal is enabled, the running mode will be turn to terminal control.

23 ~ 24: Control mode selection. Control mode can be selected via ON/OFF combination of terminals. The inverter will be active this function and P0.03 later.

Table 4-5 Control mode

Terminal 2	Terminal 1	Control mode
OFF	OFF	Hold the control mode
OFF	ON	Panel control mode
ON	OFF	Terminal control mode
ON	ON	Serial port control mode

25 : Start traverse operation. When the traverse operation is as “manual”, the traverse function will be enabled if this terminal is enabled, see Group P9 for details.

26 : Reset traverse operation. No matter the traverse operation is “Manual” or “Auto”, close-loop this terminal will clear all the memorized information of traverse operation. Disconnect this terminal can restart traverse operation. Refer to P9 for parameters instruction.

27: Close-loop disabled. The terminal can be used to flexible switching the close-loop operation and low level operation, and the setting of start/stop control, direction, Acc/Dec time mode in low level operation.

Note: Switching between close-loop operation and low level operation can be realized only when close-loop is enabled (P7.00 =1).

28: Pause the PLC operation. The terminal is used to realize pause control, when this terminal is enabled, the inverter will run in 0 Hz and PLC will not accumulate time; when this terminal is disabled, inverter will start with auto speed and PLC continue to run. Refer to group P8 for instructions.

29: PLC disabled. This terminal can be used to flexible switching the PLC operation and low level operation.

Note: The switching between PLC operation and low level operation only when PLC is running (the unit's place of P8.00 is not to 0)

30: Reset PLC stopping status. When PLC is in stopping status, the enabled terminal can clear PLC running stage, running time, running frequency and other informations of PLC stopping memory. Refer to P8 for instructions.

31: Frequency reference is input via CI. Frequency reference is input via CI forcibly when the terminal is enabled, and it will involute when the terminal is disabled.

32: Counter's trig signal input. This terminal is used to input pulse signal to the internal counter of the inverter. The highest pulse frequency is 200Hz. The present counting value can be saved at power off. See P4.22 and P4.23 for details.

33: Counter's zero-cleaning signal input. It is used to clear the counter to zero in conjunction with terminal 43.

34: External interrupt input. After receiving external interrupt input signal, inverter will lock output and running in 0 Hz, once the interrupt input signal release, the inverter will start on the fly and continue the PLC operation.

35: Pulse frequency input (only valid for X6) .This terminal can receive pulse signal as reference frequency, please refer to P1.11~P1.15 for the relationship between pulse frequency of input signal and reference frequency.

36: Actual length clearing input. If this terminal is enabled, the actual length parameter P9.09 will be cleared to zero.

P4.08	FWD/REV operation m	Range: 0~3	0
--------------	----------------------------	-------------------	----------

ode selection

This parameter defines four operation modes via which external terminals can control inverter.

0: 2-wire control mode 1

K2	K1	Running Command
0	0	Stop
0	1	Forward
1	0	Reverse
1	1	Stop

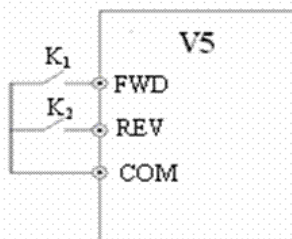
**Fig.4-21 2-wire operation mode 1****1: 2-wire control mode 2**

K2	K1	Running Command
0	0	Stop
1	0	Forward
0	1	Reverse
1	1	Stop

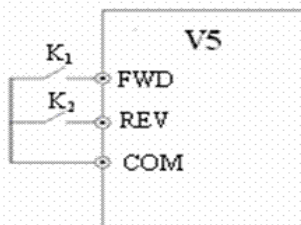
**Fig.4-22 2-wire operation mode 2****2: 3-wire control mode 1**

SB1: Stop button

SB2: Forward button

SB3: Reverse button

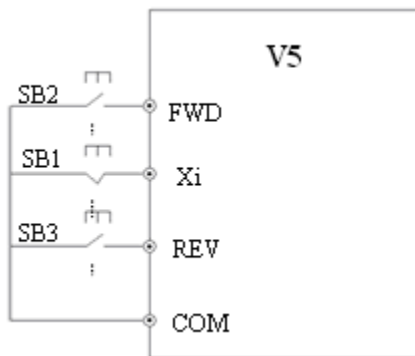

Fig. 4-23 3-wire operation mode 1

X_i is the multi-function input terminal of $X_1 \sim X_6$, here you should define its function as No.9 “3-wire control mode”.

3: 3-wire control mode 2

SB1: Stop button

SB2: Running button

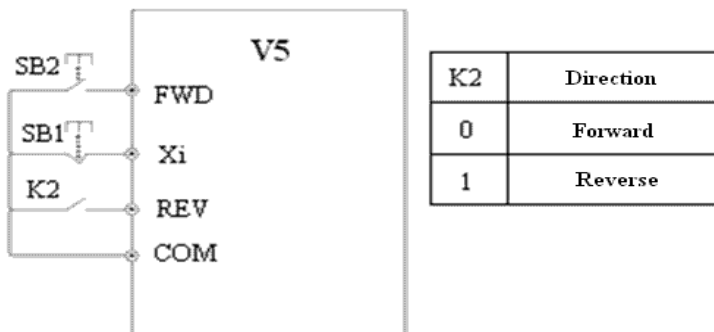

Fig.4-24 3-wire control mode 2

Xi is the multi-function input terminal of X1~X6, here you should define its function as No.9 “3-wire control mode”.

Note: When the inverter stops due to fault, it will start immediately if the terminal control mode and terminal FWD/REV are enabled and the fault is cleared.

P4.09	UP/DOWN speed rate	Range: 0.01~99.99Hz/s	1.00 Hz/s
--------------	---------------------------	------------------------------	------------------

This parameter defines the change rate of reference frequency that is changed by UP/DOWN.

P4.10	Bi-direction open-collector output terminal OC	Range: 0~20	0
P4.11	Relay output selector	Range: 0~20	15

Bi-direction open-collector output terminal OC , the options of this parameter are shown in Table 4-6.

Table 4-6 Functions of output terminals

Setting	Functions	Setting	Functions
0	Inverter running (RUN)	11	PLC is finished after one cycle
1	Frequency arriving signal(FAR)	12	Specified counting value arriving
2	Frequency detection threshold (FDT1)	13	Mid counting value arriving
3	Frequency detection threshold (FDT2)	14	Inverter Ready running finished (RDY)
4	Overload pre-alarm (OL)	15	Inverter fault
5	Inverter under voltage locking (LU)	16	Start frequency running time
6	External fault stop (EXT)	17	Start DC injection braking time

7	Output frequency arrive upper limit (FH)	18	Stop braking time
8	Output frequency arrive lower limit (FL)	19	High and lower limits of traverse operating frequency
9	Inverter zero speed running	20	set running time arriving
10	Simple PLC Pause running	21	

Instructions of the functions shown in Tabel 4-6:

0: Inverter running (RUN) . Inverter is in the running status and the terminal outputs indication signal.

1: Frequency arriving signal (FAR) . Refer to P4.12 for function instruction.

2: Frequency detection threshold (FDT1) . Refer to P4.11~ P4.12 for function instruction.

3: Frequency detection threshold (FDT2) . Refer to P4.13~P4.14 for function instruction.

4: Overload pre-alarm (OL) . If the output current is higher than the value defined by P4.24

and the time is longer than the value defined by P4.25, the inverter will output indicate signals. This function is mainly used in pre-alarm.

5: Inverter under voltage locking (LU) . While inverter is in running process, if the DC injection bus voltage is lower than the limit value, “E-11” will be displayed in LED and indicate signal will be output.

6: External fault stop (EXT) . An indicate signal will be output if inverter outputs triggering signal caused by external fault.

7: Output frequency arrive upper limit (FH) . An indicate signal will be output if reference frequency \geq upper limit of frequency and the running frequency arrives the upper limit of frequency.

8: Output frequency arrive lower limit (FL) . An indicate signal will be output if reference frequency \leq lower limit of frequency and the running frequency is lower than low limit of frequency.

9: Inverter zero speed running. The output frequency of inverter is 0 , while the terminal will output indicate signal when inverter is in running status.

10: Simple PLC Pause running finished. An indicate signal (single pulse signal, 500ms width) will be output if the present stage of PLC operation is finished.

11: PLC is finished after one cycle running. An indicate signal (single pulse signal, 500ms width) will be output if one cycle running of simple PLC is finished.

12: Specified counting value arriving

13: Mid counting value arriving

12,13 refer to P4.22~P4.23 for function instruction.

14: Inverter Ready running finished (RDY) .If RDY signal is output, it means the drive has no fault, its DC bus voltage is normal and it can receive starting command.

15: Inverter fault. If there is fault with inverter, indicate signal will be output.

16: Start frequency running time

17: Start DC injection braking time

18: Stop braking time

19 : Upper and lower limits of traverse operating frequency.An indicate signal will be output if the traverse operating frequency calculated by central frequency is higher than upper limit of frequency (P0.19) or lower than the lower limit of frequency (F0.20), as shown in Fig. 4-25.

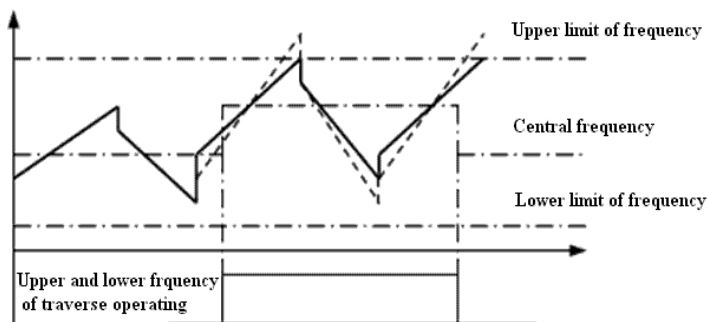

Fig.4-25 Upper and lower limits of traverse operating frequency

20: Set running time arriving. When the accumulating time (P3.40) arrive the reference time (P3.39), an indication signal will be output.

P4.12	Detecting range of frequency arrive (FAR)	Range: 0.00~50.00Hz	5.00Hz
--------------	--	----------------------------	---------------

This parameter is the additional definition of No. 1 function in Table4-6. As shown in Fig.4-26, when the output frequency of inverter is within the detecting range of reference frequency, pulse signal will be output.

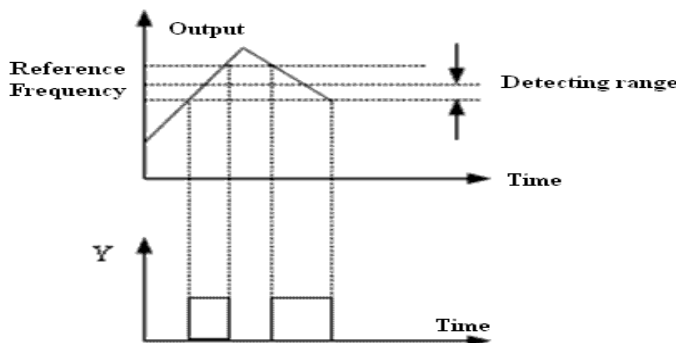

Fig 4-26 Frequency arriving signal

P4.13	FDT1 (frequency) level	Range : 0.00 ~ upper limit of frequency	10.00Hz
P4.14	FDT1 lag	Range: 0.00~50.00Hz	1.00Hz
P4.15	FDT2 (frequency) level	Range : 0.00 ~ upper limit of frequency	10.00Hz
P4.16	FDT2 lag	Range: 0.00~50.00Hz	1.00Hz

P4.13 ~ P4.14 is the additional definition of No.2 function in Fig.4-6, P4.15 ~ P4.16 is the additional definition of No.3 function in Fig.4-6, The both have the same usage and the following take P4.13 ~ P4.14 as an example to introduce. When the output frequency over a certain frequency (FDT1 level), indication signal will be output until the output frequency fall to the value which is lower than the certain frequency (FDT1 level - FDT1 lag), as shown in Fig. 4-27.

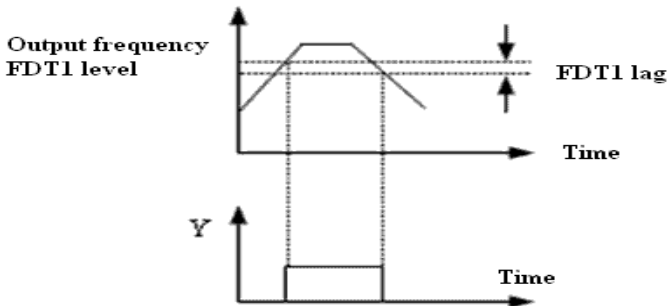

Fig.4-27 FDT level

P4.17	Analog output selection (AO)	Range: 0~7	0
P4.18	Analog output gain (AO)	Range: 0.50~2.00	1.00

Table 4-7 Output terminals

No.	Function	Range
0	Output frequency	0~upper limit of frequency
1	Output current	0-2×rated current
2	Output voltage	0-1.2×rated voltage of load motor
3	Bus voltage	0-800V
4	PID reference	0~10V
5	PID feedback	0~10V
6	VI	0~10V
7	CI	0~10V/4~20mA

As to the analog output of AO, you can adjust the output gain to change the measuring range or calibrate the meter.

P4.19	AO output mode	Range: 0、1	1
--------------	-----------------------	-------------------	----------

0: 4 ~20mA

1: 0 ~10V

P4.20	DO output terminal	Range: 0~7	0
--------------	---------------------------	-------------------	----------

Refer to Table 4-7 for function selection of DO output terminal.

P4.21	DO max pulse output frequency	Range: 0.1~20.0 (max 20K)	10.0K
--------------	--------------------------------------	----------------------------------	--------------

This parameter defines the max output frequency of DO terminal.

P4.22	Preset counting value arriving	Range: P4.23~9999	0
P4.23	Mid counting value arriving	Range: 0~P4.22	0

P4.22, P4.23 are the additional definition of No.12,13 functions in table 4-6.

Preset counting value arriving: It defines after Xi receives the relay or OC (bi-direction open-collector output terminal) will output a signal.

For example: as shown in Fig. 4-28, when the eighth pulse signal is received by terminal Xi, OC outputs an indicating signal and $F7.33=8$ at this time.

Mid counting value arriving: When Xi receives the number of pulse F7.34, OC or the relay will output a signal which will last until preset counting value arrives.

As shown in Fig. 4-28, when Xi receives the 5th pulse, the relay outputs an indication signal. It lasts until Xi receives the 8th pulse. At this time, $P4.23=5$. The mid counting value will be disabled if it is bigger than preset counting value.

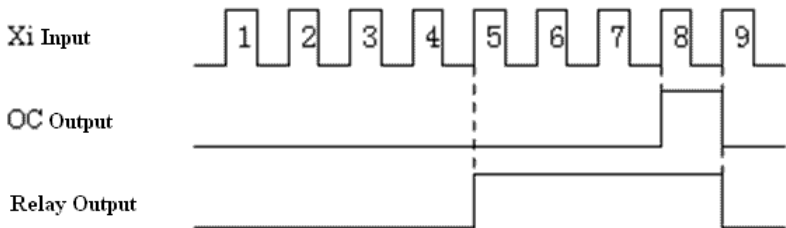

Fig.4—28 Preset counting value arriving and Mid counting value arriving

P4.24	Overload pre-alarm detection level	Range: 20—200(%)	130(%)
P4.25	Overload pre-alarm delay time	Range: 0.0—20.0S	5.0S

If output current over the detecting level set by P4.24 continuously (Actual detecting current level = $P4.24 \times$ inverter's rated current), Bi-direction open-collector will output available signal after the delay time set by P4.25(refer to Fig.4-29 and P4.11 for details).

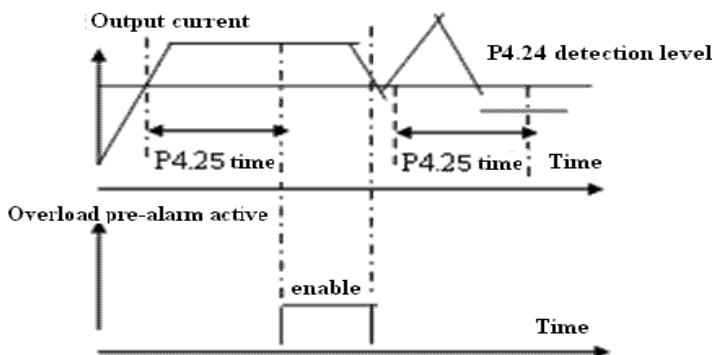

Fig.4-29 Overload pre-alarm

4-2-6. Protective function parameters (Group P5)

P5.00	Motor overload protection mode selection	Range: 0,1	0
-------	--	------------	---

This parameter defines the protection mode when overload or overheat occurs.

0: Inverter locking output. When overload or overheat occurs, inverter will lock output and the motor will coast-to-stop.

1: Disabled. Motor will be without overload protection and inverter will do the overload protection for the motor.(Cautions to using)

P5.01	Motor's overload protection coefficient	Range: 20(%)–120(%)	100(%)
-------	---	---------------------	--------

This parameter is used to set sensitivity of thermal relay protection from inverter to overload. When the output current value of load motor can not

match the rated current of the inverter, correct thermal protection can be realized by setting this parameter, as shown in Fig.4-30.

Use the following coefficient to calculate.

$$[P5.01] = \frac{\text{Motor rated current}}{\text{Inverter's rated output current}} \times 100$$

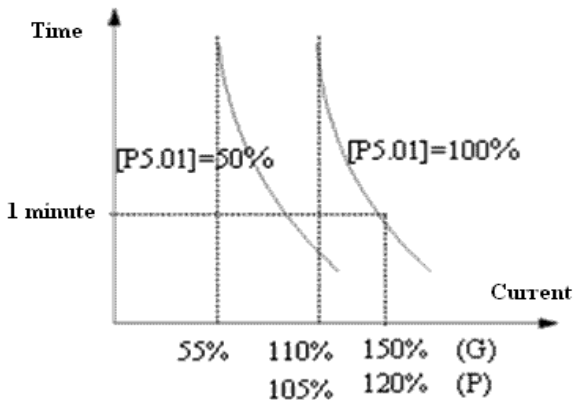

Fig.4-30 Thermal relay protection

Note : When one inverter run with multi-motors, inverter's thermal relay protection will be disabled. Therefore, please install thermal relay in the wire end of each motor to protect motor more efficiently.

P5.02	Protection of over load at stall	Range: 0,1	1
P5.03	Over voltage point at stall	Range: 380V: 120~150(%) 220V: 110~130(%)	140(%) 120(%)

0: Prohibit

1: Permit

During deceleration, the motor's decelerate rate may be lower than that of inverter's output frequency due to the load inertia. At this time, the motor will feedback the energy to the drive, resulting in the voltage rise on the inverter's DC bus. If no measures taken, the inverter will trip due to over voltage.

During the deceleration, the inverter detects the bus voltage and compares it with the over voltage point at stall defined by P5.03. If the bus voltage exceeds the stall overvoltage point, the inverter will stop reducing its output frequency. When the bus voltage becomes lower than the point, the deceleration continues, as shown in Fig.4-31.

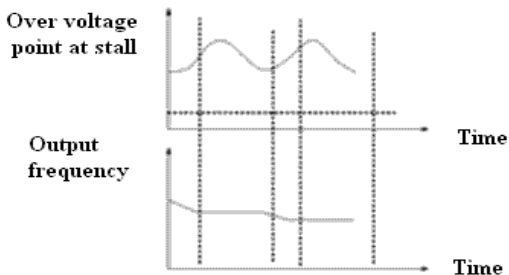

Fig. 4-31 Over voltage function

P5.04	Auto current limiting threshold	Range: 110~200(%)	150(%)
P5.05	Frequency decrease rate when current limiting	Range: 0.00~99.99Hz / S	10.00Hz/S
P5.06	Auto current limiting sele	Range: 0, 1	1

	ction		
--	-------	--	--

Auto current limiting function is used to limit the load current smaller than the value defined by P0.54 in real time. Therefore the inverter will not trip due to surge over-current. This function is especially useful for the applications with big load inertia or big change of load.

Auto current limiting threshold (P5.04) defines the threshold of auto current limiting. The range of it is a percentage of the inverter's rated current.

Frequency decrease rate when current limiting (P5.05) defines the rate of output frequency when the inverter is in auto current limiting status.

If the decrease rate is set too small, auto current limiting status may not be switched and overload fault may occur. If it is set too big, the frequency will change too sharply and thus the inverter may be in generating status for long time, which may result in overvoltage protection.

Auto current limiting function is always enabled in Acc or Dec process. Whether it is enabled in constant speed operating process is decided by auto current limiting selection (P5.06).

P5.06 = 0, Auto current limiting function is disabled in constant speed operating process;

F5.06 = 1, Auto current limiting function is enabled in constant speed operating process;

In auto current limiting process, the inverter's output frequency may change; therefore, when the inverter's output frequency is required to be stable, this function is not recommended.

P5.07	Setting of restart after power off	Range: 0,1	0
P5.08	Holding time of restart after power off	Range: 0.0~10.0S	0.5S

P5.07 = 0, Restart after instantaneous power off is disabled.

P5.07 = 1, Restart after instantaneous power off is enabled.

If instantaneous power off (E-11 displayed in inverter's LED) occurs when inverter is in running status, after repowering, it will detect speed automatically and then restart after the reference holding time (set by P5.08). During the holding time of restart, the inverter will not start even if you input running command, while if you input stop command, the inverter will stop detecting and restarting.

P5.09	Auto reset times of fault	Range: 0~10	0
P5.10	Auto reset interval of fault	Range: 0.5~20.0S	5.0S

When the inverter is in running process, it may occur fault and stop output by accident for overload fluctuating. To avoid the pause of the device, you can use auto reset times of fault. In the resetting process, inverter will restart with detecting function. If the inverter can not reset to running successfully in the reference times, fault protection will be enabled and output will be stopped.

Note: (1) When use this function, make sure that it is permissible by device and there is no substantiality fault with inverter.

(2) This function is disabled with the fault protection caused by overload and overheat.

4-2-7. Fault recording parameters (Group P6)

P6.00	Previous fault record	Range: 0~23	0
P6.07	2 latest fault record	Range: 0~23	0
P6.08	3 latest fault record	Range: 0~23	0
P6.09	4 latest fault record	Range: 0~23	0
P6.10	5 latest fault record	Range: 0~23	0
P6.11	6 latest fault record	Range: 0~23	0

0: no fault

1~17: E-01~E-17 fault, refer to chapter 5 for fault types.

P6.01	Output frequency of previous fault	Range: 0~upper limit of frequency	0
P6.02	Setting frequency of previous fault	Range: 0~upper limit of frequency	0
P6.03	Output current of previous fault	Range: 0~999.9A	0
P6.04	Output voltage of previous fault	Range: 0~999V	0
P6.05	DC injecting bus voltage of previous fault	Range: 0~800V	0
P6.06	Module temperature of previous fault	Range: 0~100	0

4-2-8. Close-loop control parameters (Group P7)

Analog feedback control system

Reference pressure is input via VI, and feedback value (4~20mA) of pressure sensor is input to inverter via CI. Also, there is an internal PI adjustor to form analog close-loop control system, as shown in Fig4-32.

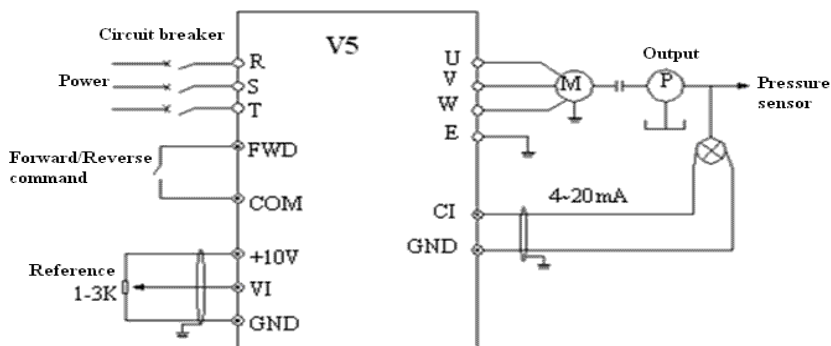

Fig.4-32 Analog feedback control system with internal PI

Principle diagram of inverter's internal PI is shown below:

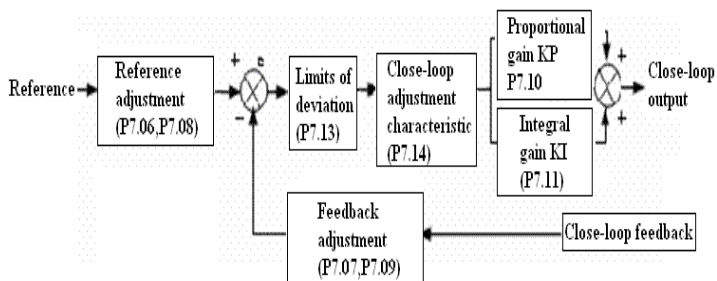

Fig. 4-33 PI block diagram

Close-loop reference, feedback, limits of deviation, proportional and integral parameters which are as same as common PI adjustment are defined in P7.01~P7.11. The relationship between reference and feedback are shown in Fig4-34, thereinto, 10V corresponds to 100% of reference and 20mA corresponds to 100% of feedback.

The aim of reference adjustment and feedback adjustment is to confirm the corresponding relationship and dimension of unification, as shown in Fig.4-33.

If the motor's speed is required to increase with the reference speed, this kind of control characteristic is called positive characteristic. On the contrary, if the motor speed is required to decrease when the reference value increases, this control characteristic is called negative characteristic.

The two close-loop characteristic can be set by P7.14, as shown in Fig4-35.

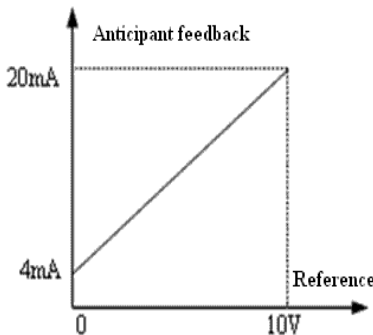

**Fig.4-34 Reference and
anticipant feedback**

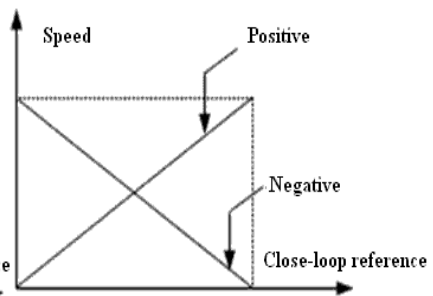

**Fig.4-35 Close-loop adjustment
characteristic diagram**

After conforming the system, the procedure of setting close-loop

parameters is shown below:

- (1) Confirm the close-loop reference and feedback channel (P7.01, P7.02).
- (2) The relationship between close-loop reference and feedback value (P7.06~P7.09) should be defined for close-loop control.
- (3) If reference and required motor's speed is opposite, please set close-loop characteristic as negative to confirm close-loop adjustment characteristic (P7.14=1), as shown in Fig4-35.
- (4) Set the function of close-loop preset frequency (P7.16~ P7.17).
- (5) Set close-loop filter time, sampling cycle T, limits of deviation and gain coefficient (P7.03, P7.04, P7.12, P7.13).

P7.00	Close-loop function selection	Range: 0, 1	0
--------------	--------------------------------------	--------------------	----------

0: Close-loop control is disabled

1: PI close-loop control is enabled

P7.01	Reference channel selection	Range: 0, 1, 2	1
--------------	------------------------------------	-----------------------	----------

0: Digit input

1: VI (0—10V)

2: CI. 0~10V voltage or 4~20mA current reference, for speed close-loop, analog reference of 10V corresponds to the synchronized speed of the motor's max output frequency.

P7.02	Feedback channel selection	Range: 0~6	1
--------------	-----------------------------------	-------------------	----------

0: VI (0—10V)

1: CI

2: VI +CI

3: VI - CI

4: Min {VL, CI}**5: Max {VL, CI}**

P7.03	Reference filter	Range: 0.01~50.00S	0.50S
P7.04	Feedback filter	Range: 0.01~50.00S	0.50S

Both the external reference signal and feedback signal have interferences, while these can be filtered by setting the time constant of filter (P7.03 and P7.04), the longer the filter time, the better the immunity capability, but the slower the response; on the contrary, the shorter the filter time, the worse the immunity capability, but the quicker the response.

P7.05	Set reference in digital mode	Range: 0.00—10.00V	0.00V
--------------	--------------------------------------	---------------------------	--------------

If P7.01=0 the value set by P7.05 will be as the reference of close-loop control system. Therefore, you can modify the value of P7.05 to change it via operation keyboard or serial port.

P7.06	Min reference	Range: 0.0—Max reference	0.0%
P7.07	Feedback value corresponding to min reference	Range: 0.0—100.0(%)	0.0%
P7.08	Max reference	Range: min reference - 100.0(%)	100.0%
P7.09	Feedback value corresponding to max reference	Range: 0.0%—100.0(%)	100.0%

P7.06 ~ P7.09 define the relationship curve of analog close-loop reference and expecting feedback. The reference value is the percentage of real value of feedback corresponding to benchmark value (10V or

20mA), as shown in Fig.4-36.

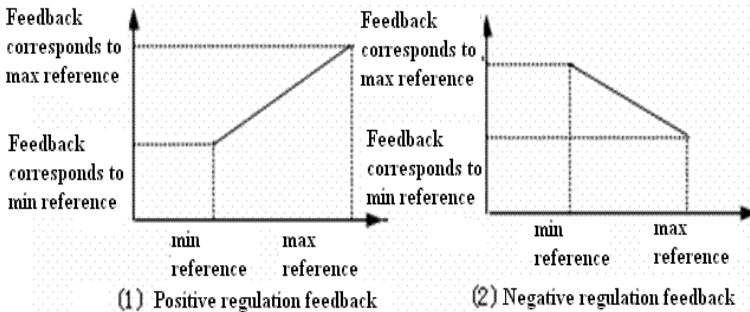

Fig. 4-36 reference and feedback curve

P7.10	Proportional gain KP	Range: 0.000~9.999	0.050
P7.11	Integral gain KI	Range: 0.000~9.999	0.050
P7.12	Sampling cycle T	Range: 0.01—10.00S	1.00S

The bigger the proportion gain KP, the quicker the response, while too bigger of it may lead to surge easily.

As only with proportion gain KP, deviation can not be eliminated, integral gain KI can be used to form PI control to eliminate the deviation. The bigger of the Ki, the quicker the response of changing deviation, while too big of the Ki may lead to surge easily.

Sampling cycle T is the sampling cycle of feedback value. PI regulator calculate once in every sampling cycle, the longer the cycle, the slower the response.

P7.13	Limits of deviation	Range: 0.0—20.0(%)	2.0(%)
--------------	----------------------------	---------------------------	---------------

The max deviation value of close-loop reference is shown in Fig.4-37, if the feedback value is within this range, PI regulator will stop operation. This function is useful to improve accuracy and stability of the system.

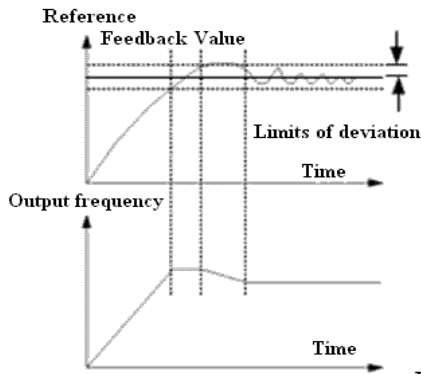

Fig.4-37 Limits of deviation

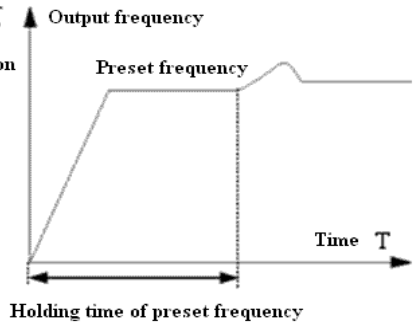

Fig.4-38 close-loop preset frequency

P7.14	Close loop adjustment characteristic	Range: 0, 1	0
-------	---	--------------------	----------

0: Positive When the reference increases, it will be enabled when the motor speed increase.

1: Negative When the reference increases, it will be enabled when the motor speed reduces

Note: Define the relationship of reference and speed.

P7.15	Integral adjustment selection	Range: 0, 1	0
-------	--------------------------------------	--------------------	----------

0: Stop integral adjustment selection when the frequency reaches upper limit or lower limits

1: Continue the integral adjustment selection when the frequency reaches high limit or lower limits

For the system need quick response, cancel the continuous integral

adjustment is recommended.

P7.16	Close-loop preset frequency	Range: 0—upper limit of frequency	0.00Hz
P7.17	Holding time of close-loop preset frequency	Range: 0.0—250.0S	0.1S

This function can make the close-loop adjustment enter stable stage quickly.

When the close-loop starts, the frequency will accelerate to the preset value set by P7.16 according to Acc time and the inverter will running with this frequency in the holding time set by P7.17, then running according to close-loop character, as shown in Fig4-38.

Note: If the function of close-loop preset frequency is not needed, you can set the preset frequency and holding time as 0.

P7.18	PI Threshold of zero-frequency operation	Range: 0.00—500.0Hz	0.01Hz
P7.19	PI hysteresis of zero-frequency operation	Range: 0.00—500.0Hz	0.01Hz

The two function parameter is used for setting PI threshold and hysteresis of zero-frequency operation.

If you set the frequency as 0 Hz, PI threshold of zero-frequency operation will be disabled.

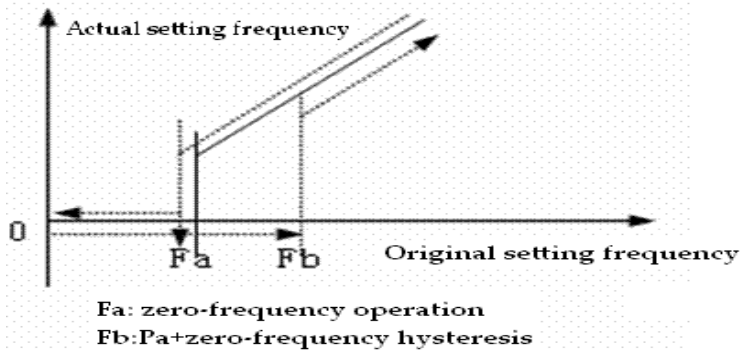

Fig.4-39 zero-frequency hysteresis

As shown in Fig.4-39

Start process:

After start command is set out, the motor will start and accelerate to the frequency in the Acc time until the setting frequency reach or exceeds the certain value Fb.

Stop process:

The inverter will not stop immediately if the setting frequency is lower than Fb, only when the setting frequency reach Fa, the inverter will stop output.

Fa points to zero-frequency threshold which is defined by P7.18, the value among Fb-Fa point to zero-frequency hysteresis which is defined by P7.19.

This function can enable the inverter to enter dormant state so as to save energy, besides, the inverter will not start at the threshold of zero-

frequency operation if the hysteresis is set properly.

4-2-9. Simple PLC operation parameters. (Group P8)

Simple PLC function can enable the inverter to change its operating frequency and directions automatically to satisfy the manufacturing requirements, as shown in Fig4-40.

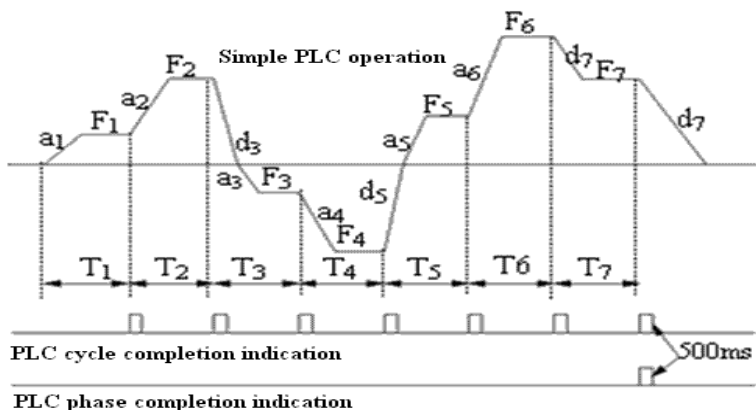

Fig.4-40 Simple PLC diagram

In Fig.4-40, $a_1 \sim a_7$, $d_1 \sim d_7$ are the Acc/Dec time of different stages and they are set by Acc/Dec time parameters P0.17, P0.18 and P3.14 ~ P3.2, $F_1 \sim F_7$, $T_1 \sim T_7$ are the running frequency and running time and they are set by P8.01 ~ P8.14.

P8.00	Simple PLC operation mode selection	Range(LED): Unit's place : 0~3; Ten's place: 0,1; Hundred's place: 0,1; Thousand's place: 0,1	0000
--------------	--	---	-------------

Unit's place of LED: PLC operation mode selection

0: Disabled.

1: Stop after operating for one cycle. As shown in Fig.4-41. If inverter stop after single cycle operation, running command should be give once again to start the inverter.

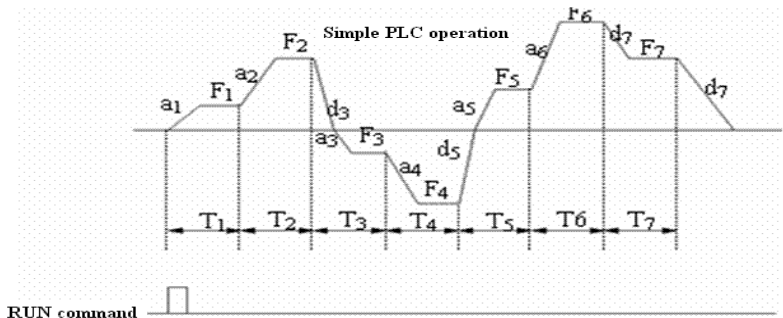

Fig. 4-41 PLC stop mode after single cycle of operation

2: Holding at the final value after single cycle of operation. As shown in Fig.4-42, Inverter will keep the running frequency, direction of the last setting automatically after single cycle is completed, then it will stop with the reference Dec time if stop command is input.

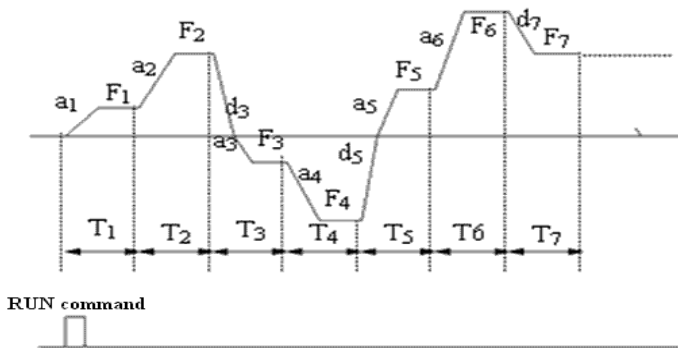

Fig. 4-42 PLC holding mode after single cycle

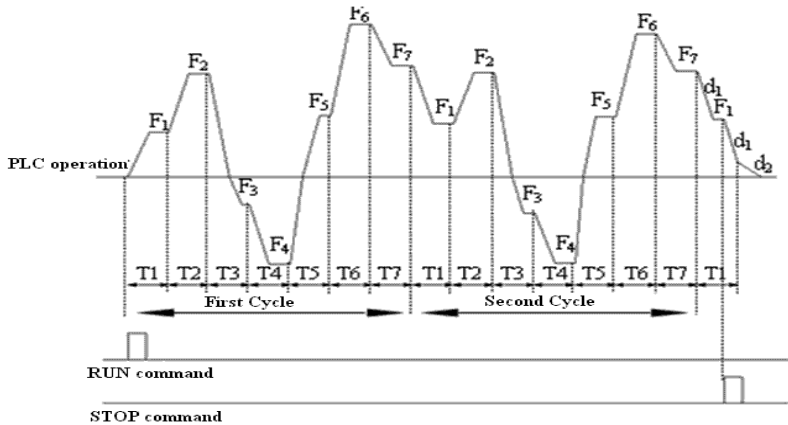

Fig. 4-43 PLC operate continuously mode

3: Operate continuously. As in Fig.4-43 , inverter start next cycle automatically after operating for one cycle, it will stop until stop command is input.

Ten's place:

Restarting mode after stopping

0: Run again for stage 1

1: Continue to run from the stopping stage

Hundred's place:

Save at power off

0: Not saving

1: Save the time and frequency at power off

Thousand's place: Selecting the unit of time

0: second

1: minute

Ten's place of LED: PLC restarting mode after stopping

0: Run again from stage 1. Inverter will start to run from stage 1 if the stop is caused by stop command, fault or power off.

1: Continue to run from the stopping stage. For the stop caused by stop command or fault, inverter will record the time in current phase automatically, then restart to enter this stage with the same frequency and run continuously in the rest time, as shown in Fig.4-44.

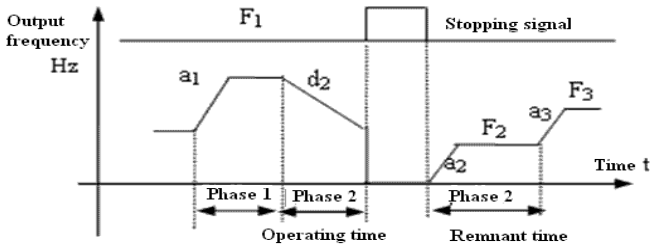

a_1 : Acc time of stage1 a_2 : Acc time of stage2 a_3 : Acc time of stage3

d_2 : Dec time of stage2 F1:Frequency of stage1 F2:Frequency of stage2 F3:Frequency of stage3

Fig.4-44 PLC start mode 1

Ten's place of LED: Save at power off

0: Not saving. The inverter does not save the PLC operating status after power off and restart to operate in first stage.

1: Save. Save the operating parameters of PLC operation after power off, including the operating stage, operating frequency and operating time. The inverter will continue to operate in the mode defined by the ten's place.

Thousand's place of LED: PLC running time

0: second

1: minute

This unit only valid for the definition of PLC running time. The unit of Acc/Dec time during PLC is running is set by P0.16.

- Note:** (1) This stage is invalid when the PLC running time is set as 0.
 (2) You can control pause, invalidation, run and others for the PLC process via terminals, refer to group P4 for details.

P8.01	Stage 1 setup	Range: 000—621	000
P8.02	Operating time of stage1	Range: 0.1—6000.0	10.0
P8.03	Stage 2 setup	Range: 000—621	000
P8.04	Operating time of stage 2	Range: 0.1—6000.0	10.0
P8.05	Stage 3 setup	Range: 000—621	000
P8.06	Operating time of stage 3	Range: 0.1—6000.0	10.0
P8.07	Stage 4 setup	Range: 000—621	000
P8.08	Operating time of stage 4	Range: 0.1—6000.0	10.0
P8.09	Stage 5 setup	Range: 000—621	000
P8.10	Operating time of stage 5	Range: 0.1—6000.0	10.0
P8.11	Stage 6 setup	Range: 000—621	000
P8.12	Operating time of stage 6	Range: 0.1—6000.0	10.0
P8.13	Stage 7 setup	Range: 000—621	000
P8.14	Operating time of stage 7	Range: 0.1—6000.0	10.0

Frequency setup

0: Multi i (i=1~7)

1: Frequency is decide by P0.01

Ten's place of LED: Operating direction selection

0: Run forward

1: Run reverse

2: Decided by operating instructions

Hundred's place of LED: Acc/Dec time selection

With the unit's place, ten's place and hundred's place of LED,

P8.01~P8.14 defined the running frequency, direction and Acc/Dec time of PLC:

Unit's place of LED:

0: Multi-frequency i, $i=1\sim7$, defined by P3.26~P3.32.

1: Frequency is set by P0.01

Ten's place of LED: Operating direction selection

0: Run forward

1: Run reverse

2: Decided by operating instructions

Hundred's place of LED: Acc/Dec time selection

0: Acc/Dec time 1

1: Acc/Dec time 2

2: Acc/Dec time 3

3: Acc/Dec time 4

4: Acc/Dec time 5

5: Acc/Dec time 6

6: Acc/Dec time 7

4-2-10. Traverse and measure function parameters (Group P9)

Traverse operation is widely used in textile and chemical fiber industry. The typical application is shown in Fig. 5-37. Traverse operation process: First, the drive accelerates to the preset frequency of traverse operation (F6.02) within the Acc time and then waits for certain time (F6.03). The drive transits to the central frequency within Acc/Dec time, and at last the drive traverse according to the preset traverse amplitude (F6.04), jitter frequency (F6.05), traverse cycle (F6.06) and rising time of traverse operation (F6.07) until it receives a stopping command and stops within Dec time.

The central frequency is actually the preset frequency of simple

operation (except PLC, traverse operation, jog), multi-step speed operation or PLC operations;

Traverse operating function is disabled automatically in Jog operation or close-loop operation process.

If PLC operation and traverse operation start at the same time, the traverse operation is disabled when the drive transits from one PLC operating stage to another stage. The drive will accelerate to the preset frequency of PLC operation and then start traverse operation. The drive will decelerate to stop within the Dec time set in PLC operating stage.

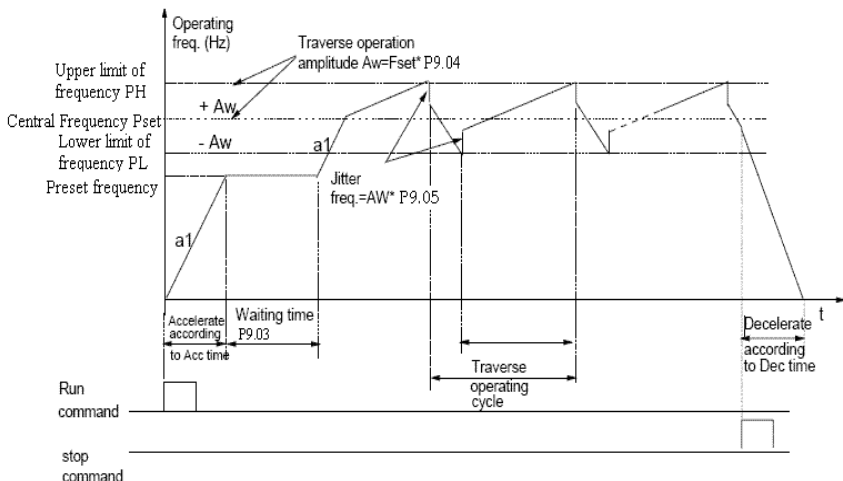

Fig.4—45 Traverse operation

P9.00	Traverse operation selection	Range: 0, 1	0
--------------	-------------------------------------	--------------------	----------

0: Disabled

1: Enabled

P9.01	Traverse operation control mode	Range: 00~11	0
--------------	--	---------------------	----------

Unit's place of LED: start mode

0: Auto mode. The inverter will running at preset frequency (P9.02) for certain time (P9.03), and then enter the traverse operation.

1: Manual mode. If the multi-function terminal (Xi is set to No.25 function) is enabled, the inverter will enter traverse mode. If the terminal is disabled, the drive will end traverse operation and operate at the pre-traverse frequency (P9.02).

Ten's place of LED: Traverse operating amplitude

0: Variable amplitude. Traverse operating amplitude AW changes with the central frequency and the change rate is defined by P9.04.

1: Fixed amplitude. Traverse operating amplitude AW is decided by max frequency and P9.04.

P9.02	Pre-traverse frequency	Range: 0.00—650.00Hz	0.00Hz
P9.03	Waiting time before pre-traverse frequency	Range: 0.0—6000.0s	0.0s

P9.02 is used to set running frequency before inverter enter traverse state.

If you select auto start mode, P9.03 is used to set the holding time with pre-traverse frequency before the inverter enter traverse state; if you select manual start mode, P9.03 is disabled. Refer to Fig. 4—45 for introduction.

P9.04	Traverse operating	Range: 0.0~50.0%	0.0%
--------------	---------------------------	-------------------------	-------------

	amplitude		
--	-----------	--	--

Variable amplitude: $A_w = \text{Central frequency} \times P9.04$

Fixed amplitude: $A_w = \text{Max operating frequency } P0.06 \times P9.04$

Prompt: The traverse frequency will be limit by upper/lower limit of frequency, and the traverse operation will not work abnormally with unsuitable setup.

P9.05	Jitter frequency	Range: 0.0~50.0%	0.0%
--------------	-------------------------	-------------------------	-------------

As shown in Fig4-45, there is no jitter frequency if P9.05 is set to 0.

P9.06	Traverse operating cycle	Range: 0.1~999.9s	10.0s
--------------	---------------------------------	--------------------------	--------------

It defines the time of a complete traverse operation cycle including rising and falling processes.

P9.07	Rising time of trangle wave	Range: 0.0~98.0%	50.0%
--------------	-----------------------------	-------------------------	--------------

Running time of traverse rising stage = $P9.06 \times P9.07$ (s), Time of falling stage = $P9.06 \times (1 - P9.07)$ (s)。Refer Fig.4—45 for introduction

Note: You can select S-curve Acc/Dec mode along with traverse so as to make the traverse operating more smoothly.

P9.08	Reference length	Range: 0.000~65.535km	0.000(km)
P9.09	Actual length	Range: 0.000~65.535km	0.000(km)
P9.10	Times of length	Range: 0.001~30.000	1.000
P9.11	correction coefficient of length	Range: 0.001~1.000	1.000
P9.12	Perimeter of shaft	Range: 0.01~100.00(cm)	10.00(cm)
P9.13	Number of pulses per revolution	Range: 1~9999	1

This group of parameters are used for fixed length control.

The drive inputs counting pulses via terminals (X6, defined as function 35), and calculate length according to the number of pulses per revolution (P9.13) and perimeter of shaft (P9.12).

Calculated length = Number of pulses \div number of pulses per revolution \times perimeter of shaft

The calculated length can be corrected through times of length (P9.10) and correction coefficient of length (P9.11), and the corrected length is the actual length.

Actual length = calculated length \times correction coefficient of length \div correcting coefficient of length

When actual length(P9.09) \geq preset length(P9.08), the inverter will send out a STOP command to stop. When the inverter restarts, it needs to clear the actual length (P9.09) or modify actual length (P9.09) < Reference length (P9.08), otherwise the inverter will not start.

Note: (1)The actual length (terminal Xi is defined as function 36) can be cleared by multi-function input terminal. The actual length can be calculated only after this terminal is disconnected.

(2) Actual length (P9.09) will be saved after power off automatically.

(3) Function of stopping at fixed length is disabled if P9.08 I set as 0, but the calculated length is still effective.

4-2-11. Vector control parameters (Group PA)

PA.00	Motor auto-turning	Range: 0, 1	0
-------	--------------------	-------------	---

0: No turning

1: Static turning

PA.01	Rated voltage of motor	Range: 0~400V	Dependent on inverter's model
PA.02	Rated current of motor	Range: 0.01~500.00A	Dependent on inverter's model
PA.03	Rated frequency of motor	Range: 1~99Hz	Dependent on inverter's model
PA.04	Rated speed of motor	Range: 1~9999 r/min	Dependent on inverter's model
PA.05	Polarity of motor	Range: 2~48	Dependent on inverter's model
PA.06	Stator inductance of motor	Range: 0.1~5000.0mH	Dependent on inverter's model
PA.07	Rotor inductance of motor	Range: 0.1~5000.0mH	Dependent on inverter's model
PA.08	Exciting inductance of motor	Range: 0.1~5000.0mH	Dependent on inverter's model
PA.09	Stator resistance of motor	Range: 0.001~50.000 Ω	Dependent on inverter's model

			model
PA.10	Rotor resistance of motor	Range: 0.001~50.000 Ω	Dependent on inverter's model

PA.01~PA.10 are set as motor parameters which have default setting dependent on inverter's model by the factory, you can reset these parameters according to the motor parameters of yours. PA.01~PA.10 are used for vector control, which should be input correctly so as to realize the expecting effect.

PA.11	Over current protection coefficient of torque	Range: 0~15	15
--------------	--	--------------------	-----------

In vector control, this parameter is used to control torque current to avoid over current, 0~15 correspond to 50%~200%.

PA.12	Percentage adjustment coefficient of speed deviation	Range: 50~120	85
PA.13	Integral adjustment coefficient of speed deviation	Range: 100~500	360

In vector control, PA.12~PA.13 are used for control motor speed. Adjust the two parameters can realize better effect for motor speed control.

PA.14	Vector torque boost	Range: 100~150	80
--------------	----------------------------	-----------------------	-----------

In vector control, this parameter is used for boosting motor's output torque. You can increase this parameter to boost motor's output torque in the place with too heavy load.

4-2-12. Specail application function parameters (Group PB)

PB.00	Jog frequency source	Range: 0~4	0
--------------	-----------------------------	-------------------	----------

0: P3.06

1: Panel potentiometer

2: P0.02

3: VI

4: CI

PB.01	selection of forward/ reverse dead time	Range: 0,1	0
--------------	--	-------------------	----------

0: Dead time is enabled. According to the value set by P0.05 with the minimum value 0.1S.

1: Dead time can be set to 0 (no dead time) .You should set $P0.05=0.0s$, $P0.20 \geq 0.5Hz$. ($P0.17 \leq 0.5S$, $P0.18 \leq 0.5S$, $P0.20 \geq 2.0Hz$, $P2.01 \geq 2.0Hz$). This function is usually used in the control process of continuous to-and-for control. If swift turn-around is needed, reduce the Acc/Dec time and increasethe lower limit of frequency/start frequency. ($P0.17 \leq 0.5S$, $P0.18$

$\leq 0.5S$, $P0.20 \geq 2.0Hz$, $P2.01 \geq 2.0Hz$) .

4-2-13. Factory setting (Group PF)



PF.00	Default password	—	—
--------------	-------------------------	---	---

PF.01	User's password	Range: 0000~9999	0000
--------------	------------------------	-------------------------	-------------

This parameter can be protect against unauthorized personnel to view or modify function parameters.

If user's password don't need, you can set 0000 as its value.

If usre's password is needed, input four figures as password ,then press to con  he password will be valid immediately.

Modification:Press  key to validate password, with correct password you can enter parameter editing status.After selecting PF.01 (PF.01=0000), input new password and press  to confirm, then the password will be valid immediately. The password for super user is “2644”.

PF.02	Software version	—	—
--------------	-------------------------	---	---

Software version is set by factory and it can not be modified by user.

5 Fault Diagnosis and Countermeasures

5-1. Fault diagnosis and countermeasures

When fault occurs, the function code and its contents will be shown in LED display, the protection function starts, the inverter stops outputting and the fault relay contact point is activated. Before seeking services, the subscriber may conduct the self-check according to the prompt given in this section, analyze the fault causes, and find out the solutions. If the fault belongs to the causes described in the broken line box, please seek the service by contacting the inverter agent or directly contacting our corporation.



Table 5-1 Fault content and countermeasures

Fault Code	Fault Type	Possible reason of fault	countermeasure
E-01	Over-current during acceleration	Too heavy the load and too short the Acc time	Prolong the Acc time
		V/F curve is not suitable	Adjust V/F curve
		The rotating motor restarts after stop	Set as “start on fly” function
		Too large the value of torque boost	Adjust the value of manual torque boost or change it as auto torque
		Inverter power is too low	Select a high power inverter
E-02	Over-current during deceleration	Too short Dec time	Prolong the Dec time
		The load generates energy or the load inertial is too big	Connect suitable braking kit
		Inverter power is too low	Select a high power inverter

E-03	Over-current during constant speed	Sudden change of load	Check and reduce the change of load
		Too short Acc/Dec time	Prolong Acc/Dec time
		Abnormal load	Check the load
		AC supply voltage is low	Check AC supply voltage
		Inverter power is too low	Select a high power inverter
E-04	Over-voltage during acceleration	Abnormal input voltage	Check input voltage
		Too short Acc time	Prolong Acc time
		The rotating motor restarts after stop	Set as “start on fly” function
E-05	Over-voltage during deceleration	Too short Dec time	Prolong Dec time
		The load generates energy or the load inertial is too big	Connect suitable braking kit
E-06	Over-voltage During constant speed operation	Abnormal input voltage	Check input voltage
		Too short Acc/Dec time	Prolong Acc/Dec time
		Abnormal change of input voltage	Install input reactor
		Too big the load inertial	Connect suitable braking kit
E-07	Inverter's control power supply over voltage	Abnormal input voltage	Check input power or ask for service
E-08	Inverter overheat	Vent obstructed	Clean the vent
		Over temperature	Improve condition and decrease carrier frequency
		Fan does not work	Change the fan
		IGBT module is abnormal	Ask for help

E-09	Inverter overload	Too short Acc time	Prolong Acc time
		DC injection braking current is too big	Reduce DC injection braking current and prolong braking time
		V/F curve is not suitable	Adjust V/F curve and torque boost value
		The rotating motor restarts after stop	Set “start of fly” function
		Low AC supply voltage	Check AC supply voltage
		Too heavy load	Select a high power inverter
E-10	Motor overload	V/F curve is not suitable	Adjust V/F curve and torque boost value
		Low AC supply voltage	Check AC supply voltage
		Common motor has operated with heavy load at low speed for a long	Select motor with frequency conversion if it requires to operate for a long time
		Unsuitable motor’s overload protection coefficient	Set motor’s overload protection coefficient correctly
		The motor is blocked or the load is too big	Check load
E-11	Low voltage during operating	Too low AC supply voltage	Check AC supply voltage
E-12	IGBT protection	Instant over current of inverter	Refer to countermeasure of over current
		Short-circuit among 3-phase output or	Rewiring

		line-to-ground short circuit	
		Vent is obstructed or fan is damaged	Clean the vent or change the fan
		Over-temperature	Reduce environment temperature
		Wires or connectors of control board are loose	Check and rewiring
		Current waveform distorted due to output phase loss	Check wiring
		Auxiliary power is damaged and inverter voltage is low	Seek factory or agent for service
		Abnormal control board	Seek factory or agent for service
E-13	Peripheral equipment fault	Emergency stop for peripheral equipment terminal close	Break external fault terminal after dealing with the external fault
E-14	Current detection circuit has fault	Wires or connectors of control board are loose	Check and rewiring
		Auxiliary power is damaged	Seek factory or agent for service
		Hall sensor is damaged	Seek factory or agent for service
		Amplifying circuit is abnormal	Seek factory or agent for service
E-15	RS485 Communication error	Baud rate is not suitable	Set suitable baud rate
		Serial port communication error	Press  key to reset, or seek service
		Improper setting of alarm	Modify the setting of P3.09~P3.

		parameter	12
		Host PC does not work	Check host PC, check the wiring
E-16	System disturbance	Severe disturbance	Press  key to reset or install power filter at the input side of the inverter
		W/R error of DSP in main control board	Press keys to reset or seek service
E-17	E ² PROM W/R error	W/R error of control parameter	Press  key to reset or seek service

5-2. Fault records

This series inverter records the codes of latest 6 fault and operating parameters of last 1 fault which can be help for finding the possible

reason of faults. All of these fault informations are saved in group P6. Please refer operation method of keyboard to enter group P6.

5-3. Fault reset

Once the fault occurs, select one of the following operations to restart the inverter:

- (1) When fault code displayed in the operation panel, press  key after you confirm the inverter can be reset.
- (2) After setting one terminal among X1 ~ X8 as external RESET input (P4.00 ~ P4.07=17), connect it with COM terminal and then disconnect them.
- (3) Cut off the power supply



Note:

- (1) Please make sure you know the reason of the fault and get rid of it before resetting, otherwise the inverter may be damaged permanently.
- (2) If the inverter can not be reset or fault reoccurred after resetting, please check the reason as the inverter may be damaged by resetting continuously.
- (3) Delay 5 minutes to reset when overload and overheat protection are enabled.

6 Maintenance

6-1. Maintenance

Environment effects such as ambient temperature, humidity, fog, internal component aging and other factors will give rise to the occurrence of potential faults. Therefore, it is necessary to conduct daily check and routine maintenance to the inverters.

6-1-1. Routine maintenance

Please confirm the following items when start the inverter.

- (1) If there is abnormal noise and vibration with the motor.
- (2) If the inverter and motor heat unusually.
- (3) If the environment temperature is too high.
- (4) If the value of load amperometer is as usual.
- (5) If the fan of inverter can operate normally.

6-2. Periodical care and maintenance

6-2-1. Periodical care

Before check and maintenance the inverter, please make sure that the inverter is power off, monitor has no display content and the indication lamp of main circuit power is off. The checked contents are shown in Tabel 6-1.

Table 6-1 periodical maintenance

Items	Contents	Countermeasures
Main circuit terminals, control circuit terminals	If the screws are loose	Tighten the screws with screw drivers
Heatsink	If there is dust	Use dry compressed air with 4~6kgcm ² pressure
PCB print circuit board	If there is dust	Use dry compressed air with 4~6kgcm ² pressure
Cooling fan	There is abnormal noise, vibration, or if it has run for more than 20 000 hours.	Change cooling fan
Power component	If there is dust	Use dry compressed air with 4~6kgcm ² pressure
Aluminium electrolytic capacitors	If it has changed color , particular smell or bubble	Change aluminium electrolytic capacitors

6-2-2. Periodical maintenance

To make the inverter work normally for long time, periodical care and maintenance for inverter's internal electronic component should be done. The electronic component's lifetime depends largely on their application environment and preservation. Normally, lifetime is:

Table 6-2 Lifetime of inverter components

Component	Life
Cooling fan	2~3 year
Electrolytic capacitors	4~5 year
Print circuit boare	5~8 year
Fuse	10 year

The usage conditions of the above components are shown below:

- (1) Environmental temperature: 30°C as average.
- (2) Load coefficient: below 80%.
- (3) Running time : below 12 hour per day.

6-3. Warranty of the inverter

Xinje electronic Co.,Ltd will offer warranty service in the case of the following situations:

- (1) The warranty clause is only confined to the inverter;
- (2) We will take the responsibility of 15 months defects liability period for any faults or damages under the normal operation conditions. After 15 months, maintenance will be charged;
- (3) Even within 15 months, maintenance would be charged under the following conditions:

Inverter is damaged due to incorrect operation, which are not in compliance with “User Manual”;

Inverter is damaged due to fire, flood, abnormal voltage and so on;

Inverter is damaged due to wiring fault.

Inverter is damaged due to the improper use of drive functions;

(4) Service fee will be charged according to the actual costs. If there are any maintenance contracts, the contract prevail.

7 Communication Protocol

7-1. Overview of communication protocol

These series inverter supply RS485 communication port and adopt MODBUS started communication protocol. Therefore, the inverter can be set as a slave to communicate with the master (such as PLC and PC) which has the same communication port and protocol; also, user can use an inverter as the master to communicate with several inverters produced by our company via RS485 port to realize multi-machine linkage. Besides, you can connect the RS485 port to remote keyboard to realize remote operation.

This inverter supports MODBUS-RTU, the following is the particular instruction for the inverter's communication protocol.

7-2. Instruction of communication protocol

7-2-1. Communicating mode

Inverter as a slave

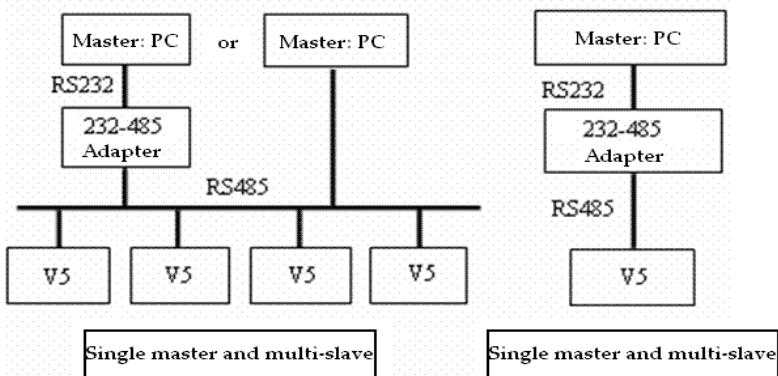

Fig.7-1 Networking diagram of inverter

Multi-device linkage

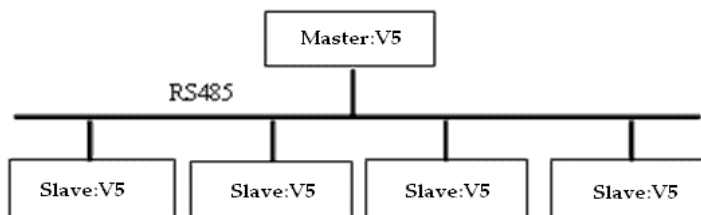

Fig 7-2 Networking diagram of multi-device linkage

7-2-2. Communication modes

The inverter can be used as both master and slave in RS485 net. If it is used as a master, it can control other inverters made by our company to realize multi-machine linkage. If it is used as a slave, PC or PLC can be set as a master to control it. The concrete communication modes are shown below:

- (1) (1) The inverter is a slave in the network. It communicates in 'point to point' mode. The inverter will not response to the command sent by the master via broadcast address.
- (2) The inverter is a master in the network, the slave will not response to the command sent by the inverter via broadcast address.
- (3) Users can set the inverter's current address, baud rate and data format by using the inverter's keypad or through the serialcommunication port.
- (4) The drive can report the current fault information when polled by the master.

7-2-3. Mode of communication port

RS485, asynchronous, semi-duplex

Default: 1bit of start bit, 8 bits of data bit, 1 bit of stop bit, 9600bps. See Group P3.09~P3.12 for parameter settings.

7-3.Modbus-RTU communication protocol

7-3-1. Structure

(1-8-2 format, None)

Start bit	0	1	2	3	4	5	6	7	Stop bit	Stop bit
-----------	---	---	---	---	---	---	---	---	----------	----------

(1-8-1 format, Odd)

Start bit	0	1	2	3	4	5	6	7	Odd	Stop bit
-----------	---	---	---	---	---	---	---	---	-----	----------

(1-8-1 format, Even)

Start bit	0	1	2	3	4	5	6	7	Even	Stop bit
-----------	---	---	---	---	---	---	---	---	------	----------

(1-8-1 format, None)

Start bit	0	1	2	3	4	5	6	7	Stop bit
-----------	---	---	---	---	---	---	---	---	----------

7-3-2. Communication information

1. RTU mode:

START	Keep the time no signal $\geq 10\text{ms}$
Address	Communication address: 8-bit binary address
Function	Function code: 8-bit binary address

DATA (n - 1)	Data: N*8-bit data, N<=8, Max=8 bit
.....	
DATA 0	
CRC CHK Low	CRC verify code
CRC CHK High	16-bit CRC verify code is combined by 2 code of 8-bit binary
END	Keep the time no signal >=10ms

2. Communication address:

00H: broadcast for all the inverters (broadcast)

01H: communicate with the inverter addressed 01

0FH: communicate with the inverter addressed 15

10H: communicate with the inverter addressed 16

By parity of reasoning....., max can reach 254 (FEH)

3. Function code and Data:

03H: Read data from registers, can read several registers with the numbers less than 31 and only can read the data in the same group every time.

06H: Write data into the register.

08H: Diagnosis

(1) Function code 03H: read register

For example: Read data from address 2104H (Output current):

RTU Mode:

Request mode		Response mode	
Address	01H	Address	01H
Function code	03H	Function code	03H

Register address	21H	Byte No.	02H
	04H		
Register No.	00H	Dada	00H
	01H		00H
CRC CHECK Low	CFH	CRC CHECK Low	B8H
CRC CHECK High	F7H	CRC CHECK High	44H

(2) Function code 06H: Write to register

For example: 01H, write function code P0.02=50.00HZ.

RTU Mode:

Request mode		Response mode	
Address	01H	Address	01H
Function code	06H	Function code	06H
Register address	00H	Register address	00H
	02H		02H
Data	13H	Data	13H
	88H		88H
CRC CHECK Low	25H	CRC CHECK Low	25H
CRC CHECK High	5CH	CRC CHECK High	5CH

(3) Command mode: 08H Diagnosis

This command is used for testing that if the communication between the client device (master) and inverter(slave) is normal. Inverter will sent the data to control device.

RTU mode:

Request mode	Response mode
--------------	---------------

Address	01H	Address	01H
Function code	08H	Function code	08H
Data	01H	Data	01H
	02H		02H
	03H		03H
	04H		04H
CRC CHECK Low	41H	CRC CHECK Low	41H
CRC CHECK High	04H	CRC CHECK High	04H

5. Verify code

RTU mode: Double bytes with hex

CRC field is the binary value has two bytes (16 bits), it is added to the message after calculating; when added, the first is low byte and the second is high byte, therefore, the last byte of the sended message is high byte. Then the receiving device cauculate CRC which has received message again and compared it with the value in CRC field. If the two values are not the same, the device will take this message as fault and abandond it without any responses, and then receive next frame data. Please refer to MODBUS protocol instruction for calculate method of CRC verification.

7-3-3. Communication parameter

Name	Parameter address	Function
Internal reference parameters	GGnnH	GG stands for parameter group , nn stands for parameter No.

Command to inverter (06H)	2000H	0001H: Running command (Forward)
		0002H: Forward command
		0003H: Reverse command
		0004H: Jog command (Forward)
		0005H: Jog forward command
		0006H: Jog reverse command
		0007H: Dec stop command
		0008H: Emergency stop command
		0009H: Jog stop command
		000AH: Fault reset command
	2001H	Set frequenc command via port
	2100H	Read inverter's fault parameter
Monitor inverter's status (03H)	2101H	Read inverter's status
		BIT0: stop indicate, 0: Stop; 1: Run
		BIT1: ,1: low voltage; 0: normal
		BIT2:forward/reverse indicate,1: forward; 0: reverse
		BIT3:jog indicate 1: jog; 0: none
		BIT4:close loop control selection, 1: close loop; 0: none
		BIT5:traverse mode running flag, 1: traverse; 0: none
		BIT6:PLC running flag, 1: PLC running , 0: no
		BIT7:Multi-speed running flag of terminals , 1 : Multi-speed; 0: none
		BIT8:Common running flag, 1: common running; 0: no
		BIT9:Main frequency from communication interface, 1: yes; 0: no
		BIT10:Analog input from main frequency, 1: yes; 0: no
BIT11:Running command from communication interface, 1: yes; 0: no		

		BIT12: Password protection for parameters, 1: yes; 0: no	
	2102H	Read inverter's reference frequency	
	2103H	Read inverter's output frequency	
	2104H	Read inverter's output current	
	2105H	Read inverter's bus voltage	
	2106H	Read inverter's output voltage	
	2107H	Read motor's speed	
	2108H	Read module temperature	
	2109H	Read analog input via VI	
	210AH	Read analog input via CI	
	210BH	Read inverter's software version	
	210CH		I/O terminal status
			Bit0: X1
			Bit1: X2
		Bit2: X3	
		Bit3: X4	
		Bit4: X5	
		Bit5: X6	
		Bit6: FWD	
		Bit7: REV	
	Bit8: OC		
	Bit9: relay output		
Read data from function code (03H)	GGnnH (GG: Group No. of function code nn :No. function code)	Inverter responses to the data (When use Modbus address, the nn must be turned into hex)	
Write data to function	GGnnH (GG: Group	Data be wrote in the inverter (When use Modbus address, the nn must be turned in	

code (06H)	No. of function code nn :No. function code)	to hex)
-------------	--	----------

Take the following as examples:

Read function code P1.02:

01H, 03H, 01H, 02H, 00H, 01H, CRC1, CRC2

Read the reference frequency of inverter:

01H, 03H, 21H, 02H, 00H, 01H, CRC1, CRC2

Write function code P1.02, the write value is 1

01H, 06H, 01H, 02H, 00H, 01H, CRC1, CRC2

Running command:

01H, 06H, 20H, 00H, 00H, 01H, CRC1, CRC2

Definition of fault code:

Fault code	Instruction
01H	Fault function code. Inverter can not find : 03H, 06H, 08H.
02H	Fault data address. Inverter can not find data address
03H	Fault data. data over the limit

Note: The parameter address must in hex format, as the function codes of parameters are in decimal system, so you must let them turn to hex. For example, the Modbus address of function code P2.11 is 020BH.

THINGET

无锡市信捷科技电子有限公司

江苏省无锡市蠡园开发区

创意产业园 7 号楼四楼

邮编： 214072

电话： 86-510-85134136

传真： 86-510-85111290

Xinje Electronic Co., Ltd.

4th Floor Building 7,Originality Industry park,

Liyuan Development Zone, Wuxi City, Jiangsu

Province, China 214072

Tel: 86-510-85134136

Fax: 86-510-85111290