

A kocsí és a sín párhuzamossága

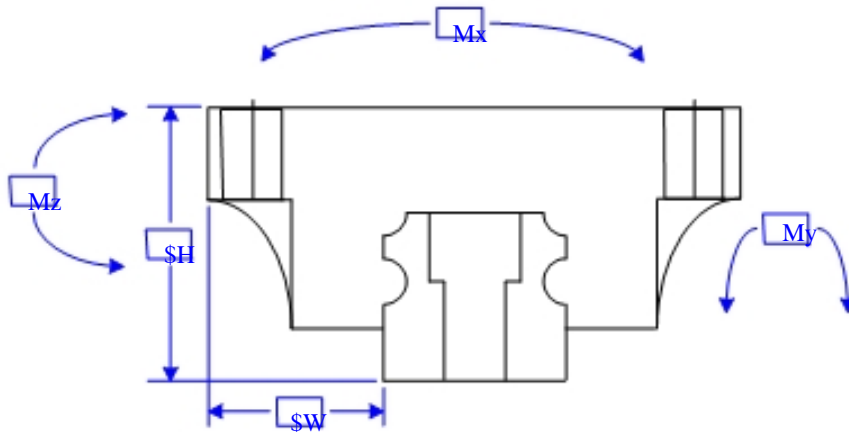
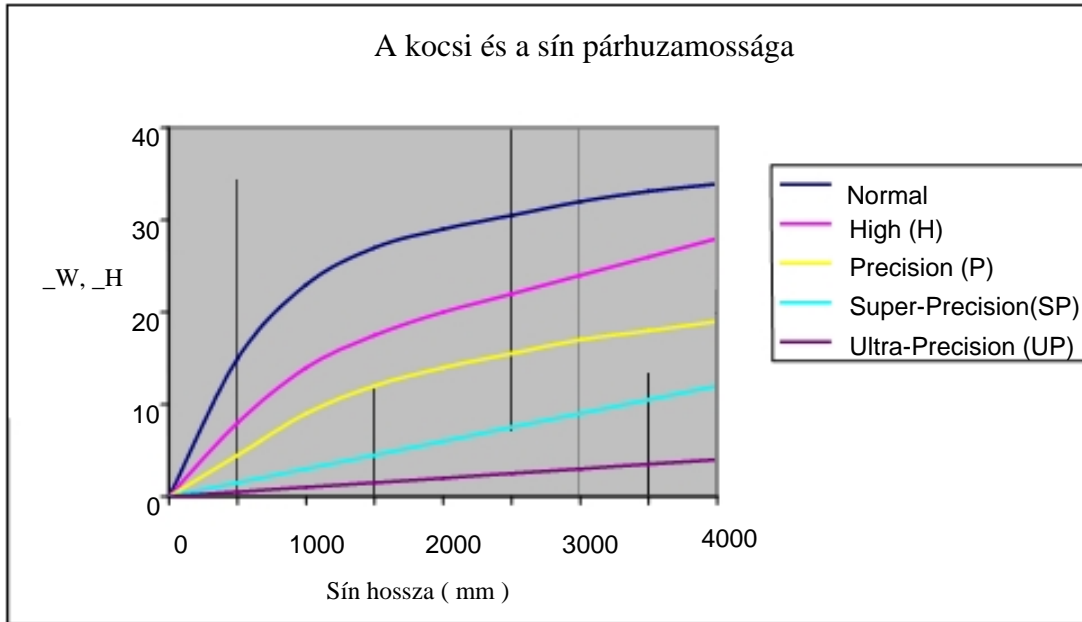

Item	Grade				
	Normal	High	Precision	Super-Precision	Ultra-Precision
Tolerance of height (mm)	± 0.1	± 0.04	0 -0.04	0 -0.02	0 -0.01
Tolerance of width (mm)	± 0.1	± 0.04	0 -0.04	0 -0.02	0 -0.01
Difference of height (mm)	0.03	0.02	0.01	0.005	0.003
Difference of width (mm)	0.03	0.02	0.01	0.005	0.003
Parallelism of height (mm)	(H (Refer to Fig 1)				
Parallelism of width (mm)	(W (Refer to Fig 1)				

Type	Terhelés (N)		Statikus nyomaték (Nm)		Súly (Kg)	
	C	C0	Mx	My/Mz	Kocsí	Sín
15	8500	16500	100	80	0.21	1.4
20	14500	25600	220	180	0.4	2.6
25	21400	40000	360	310	0.57	3.6
30	29800	54900	600	490	1.1	5.2
35	39600	70100	960	730	1.6	7.2
45	67400	121000	2160	1680	2.7	12.3

A sín méretei

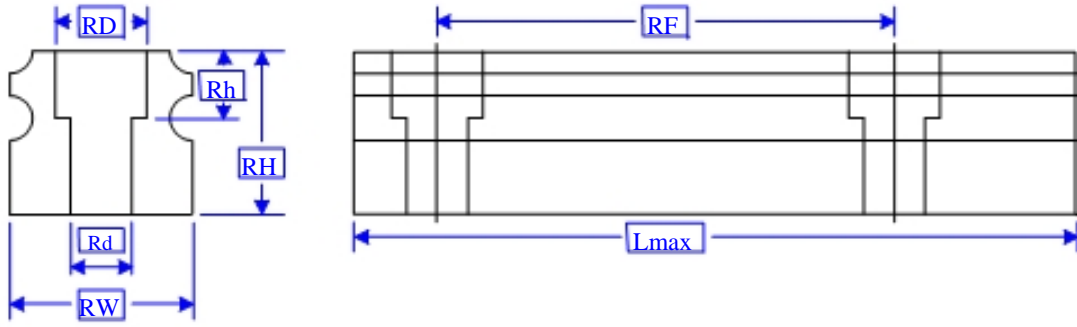

Sín (mm)								
Model	RW	RH	RD	Rd	Rh	RF	Lmax	
R15	15	14	7.5	4.5	5.3	60	4000	
R20	20	18	9.5	6	8.5	60	4000	
R25	23	22	11	7	9	60	4000	
R30	28	26	14	9	12	80	4000	
R35	34	29	14	9	12	80	4000	
R45	45	38	20	14	17	105	4000	

A peremes kocsi méretei

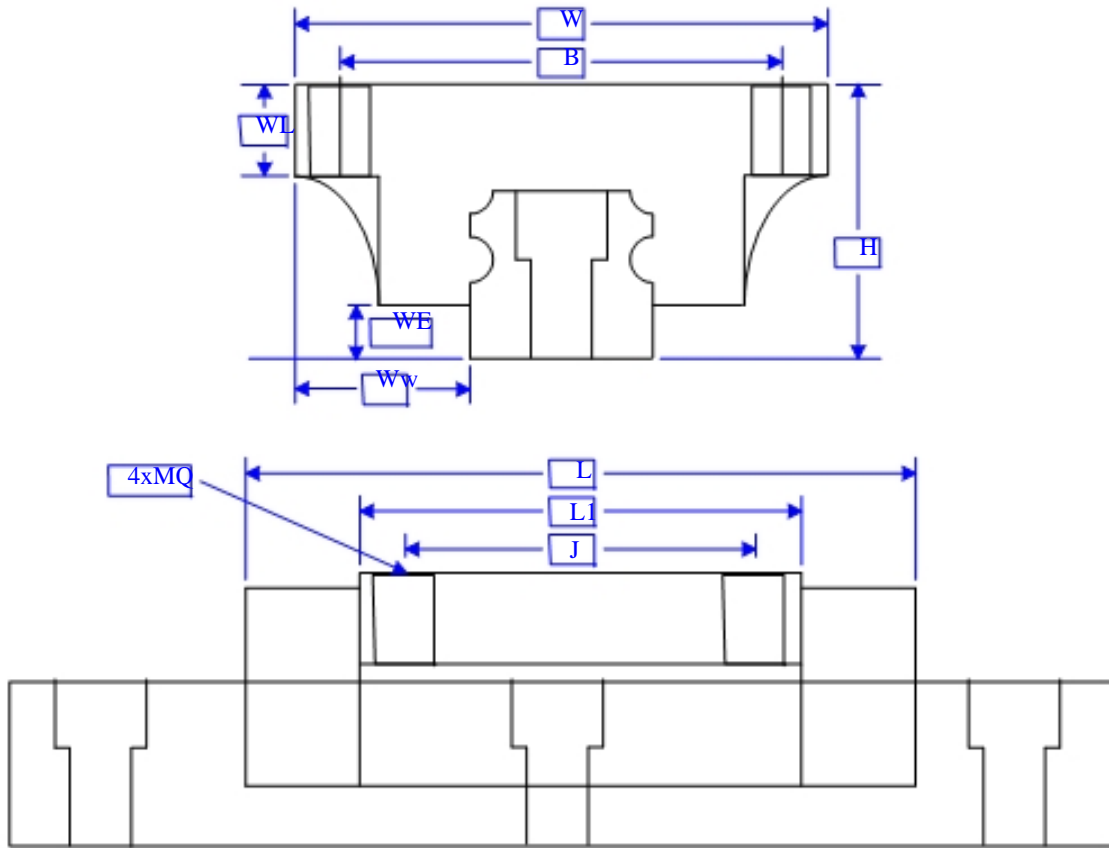

Peremes kocsi(mm)										
Model	W	H	B	J	MQ	WL	WE	Ww	L	L1
15 A	47	24	38	30	M5	8	4.6	16	66	40
20 A	63	30	53	40	M6	9	5	21.5	77.8	48.8
25 A	70	36	57	45	M8	12	7	23.5	88	57
30 A	90	42	72	52	M10	12	9	31	109	72
35 A	100	48	82	62	M10	13	9.5	33	109	80
45 A	120	60	100	80	M12	15	14	37.5	138.2	105

A perem nélküli kocsi méretei

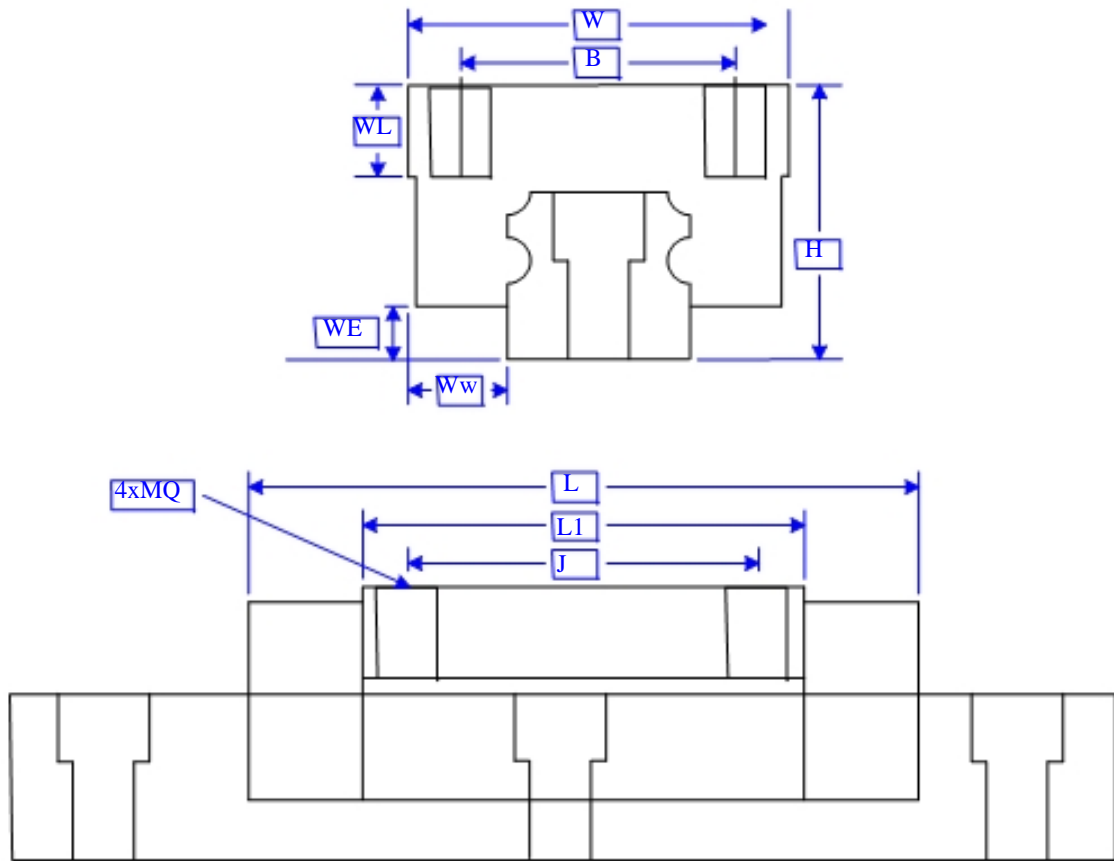

Perem nélküli kocsi (mm)										
Model	W	H	B	J	MQ	WL	WE	Ww	L	L1
15 B	34	28	26	26	M4	6.4	4.6	9.5	66	40
20 B	44	30	32	36	M5	8	5	12	77.8	48.8
25 B	48	40	35	35	M6	9.6	7	12.5	88	57
30 B	60	45	40	40	M8	12.8	9	16	109	72
35 B	70	55	50	50	M8	12.8	9.5	18	109	80
45 B	86	70	60	60	M10	16	14	20.5	138.2	105